

From: [Lindsay, Jerry \(CONTR\)](#)
To: [Water Permits](#)
Subject: [EXTERNAL] FW: APPLICATION FOR STATE OPERATING PERMIT (SOP) FOR PORTAL FACILITIES AT SECURITY ENTRANCES AT OAK RIDGE NATIONAL LABORATORY (ORNL)
Date: Wednesday, September 13, 2023 9:08:06 AM
Attachments: [image001.png](#)
[image002.png](#)
[image003.png](#)

OK, I had to split the email in half. First part is attached.

Thank you,
Jerry Lindsay
ORNL Site Office
865-576-0855



From: Water Permits <Water.Permits@tn.gov>
Sent: Tuesday, September 12, 2023 5:00 PM
To: Lindsay, Jerry Allen <lindsayijja@ornl.gov>
Subject: [EXTERNAL] FW: APPLICATION FOR STATE OPERATING PERMIT (SOP) FOR PORTAL FACILITIES AT SECURITY ENTRANCES AT OAK RIDGE NATIONAL LABORATORY (ORNL)

Hello, Jerry,

I think your pdf didn't get merged properly? I am only able to see the cover letter.

Kind regards,



Beth Rorie
William R. Snodgrass TN Tower, 11th Fl.
312 Rosa L. Parks Ave.
Nashville, TN 37243
Office: 615-532-1172
Elizabeth.Rorie@tn.gov
[customer satisfaction survey](#)

From: Lindsay II, Jerry <lindsayiija@ornl.gov>

Sent: Tuesday, September 12, 2023 9:46 AM

To: Water Permits <Water.Permits@tn.gov>

Cc: michele.branton <michele.branton@science.doe.gov>; Moore, Johnny <moorejo@ornl.gov>; Johnny Moore (Science) <johnny.moore@science.doe.gov>; Branton, Michele <brantonmg@ornl.gov>; Doty Iv, Thomas <dotytw@ornl.gov>; Doty, Walt <Walt.Doty@science.doe.gov>; Huffman, Chad <huffmanck@ornl.gov>; Huffman, Chad K <chad.huffman@science.doe.gov>; Goddard, Wesley <goddardwd@ornl.gov>; Langstaff, Jessica <langstaffjb@ornl.gov>; Muhs, Lori <muhsa@ornl.gov>; North, Todd <northta@ornl.gov>; SkipperDD <SkipperDD@ORNL.gov>; Parkison, Michael Lee <parkisonml@ornl.gov>; Directors Files (drx) <dirfiles@ornl.gov>

Subject: [EXTERNAL] APPLICATION FOR STATE OPERATING PERMIT (SOP) FOR PORTAL FACILITIES AT SECURITY ENTRANCES AT OAK RIDGE NATIONAL LABORATORY (ORNL)

***** This is an EXTERNAL email. Please exercise caution. DO NOT open attachments or click links from unknown senders or unexpected email - STS-Security. *****

Good Morning. Sent on behalf of the ORNL Site Office.

Please find the attached pdf of subject document titled, “**APPLICATION FOR STATE OPERATING PERMIT (SOP) FOR PORTAL FACILITIES AT SECURITY ENTRANCES AT OAK RIDGE NATIONAL LABORATORY (ORNL)**,” dated September 10, 2023. A hard copy will not be sent. All distribution has been made.

Thank you,

Jerry Lindsay

ORNL Site Office

865-576-0855



Chickasaw Nation Industries, LLC

Website: www.Chickasaw.com



Department of Energy

Office of Science

ORNL Site Office
P.O. Box 2008
Oak Ridge, Tennessee 37831-6269

September 10, 2023

Division of Water Resources
Tennessee Department of Environment and Conservation
3711 Middlebrook Pike
Knoxville, Tennessee 37921

To Whom it May Concern:

APPLICATION FOR STATE OPERATING PERMIT (SOP) FOR PORTAL FACILITIES AT SECURITY ENTRANCES AT OAK RIDGE NATIONAL LABORATORY (ORNL)

The two primary vehicle security portals located on both the eastern and western entrances to ORNL on Bethel Valley Road are equipped with vault toilets which were installed in 2014. These portal toilets are for security personnel who staff these portals and for individuals who may be detained while awaiting permission for access to ORNL. When we became aware of the configuration of these toilets, a discussion was held with Tennessee Department of Environment and Conservation (TDEC) on June 1, 2022, to determine the path forward on permitting. Between June 2022 and the present time, ongoing discussions with the pump and haul vendor and TDEC have occurred which resulted in the preparation of the enclosed SOP application.

If there are any questions or additional information required, please contact Lori Muhs at (865) 607-9774 or Walt Doty at (865) 576-7321.

Sincerely,

A handwritten signature in blue ink, appearing to read "Johnny O. Moore".

Johnny O. Moore, Manager
ORNL Site Office

Enclosure

cc w/enclosure:
Timothy Hill, TDEC
Michele G. Branton, SC-OSO
T. Walt Doty IV, SC-OSO
Chad K. Huffman, SC-OSO
Wesley D. Goddard, ORNL
Jessica B. Langstaff, ORNL
Lori A. Muhs, ORNL
Todd A. North, ORNL
David D. Skipper, ORNL
Michael L. Parkison, ORNL
Director's Files



Tennessee Department of Environment and Conservation
 Division of Water Resources
 William R. Snodgrass - Tennessee Tower
 312 Rosa L. Parks Avenue, 11th Floor
 Nashville, Tennessee 37243-1102
 (615) 532-0625

APPLICATION FOR A STATE OPERATION PERMIT (SOP)

Type of application: New Permit Permit Reissuance Permit Modification

Permittee Identification: (Name of city, town, industry, corporation, individual, etc., applying, according to the provisions of Tennessee Code Annotated Section 69-3-108 and Regulations of the Tennessee Water Quality Control Board.)

Permittee Name (applicant): U.S. Department of Energy, Oak Ridge National Laboratory

Permittee Address: 1 Bethel Valley Rd. Oak Ridge, TN 37831-6269

Official Contact: Johnny O. Moore	Title or Position: Manager, ORNL Site Office		
Mailing Address: P.O. Box 2008	City: Oak Ridge	State: TN	Zip: 37831-6269
Phone number(s): (865) 576-3536	E-mail: moorejo@ornl.gov		

Optional Contact: Thomas W. Doty IV	Title or Position: ORNL Site Office Staff		
Address: P.O. Box 2008	City: Oak Ridge	State: TN	Zip: 37831-6269
Phone number(s): (865) 576-7321	E-mail: dotytw@ornl.gov		

Application Certification (must be signed in accordance with the requirements of Rule 0400-40-05-.05)

I certify under penalty of law that this document and all attachments were prepared under my direction or supervision in accordance with a system designed to assure that qualified personnel properly gathered and evaluated the information submitted. Based on my inquiry of the person or persons who manage the system, or those persons directly responsible for gathering the information, the information submitted is, to the best of my knowledge and belief, true, accurate, and complete. I am aware that there are significant penalties for submitting false information, including the possibility of fine and imprisonment for knowing violations. As specified in Tennessee Code Annotated Section 39-16-702(a)(4), this declaration is made under penalty of perjury.

Name and title; print or type Johnny O. Moore	Signature 	Date 9/10/2023
--	---------------	-------------------

Facility Identification:		Existing Permit No.	
Facility Name: U.S. Dept. of Energy Oak Ridge National Laboratory		County: Roane & Anderson	
Facility Address or Location: 1 Bethel Valley Rd., Oak Ridge, TN		Latitude: 35.931388	
		Longitude: -84.310242	
Name and distance to nearest receiving waters: See attached description.			
If any other State or Federal Water/Wastewater Permits have been obtained for this site, list their permit numbers: NPDES Permit # TN0002941			
Name of company or governmental entity that will operate the permitted system: US Dept of Energy - ORNL			
Operator address: 1 Bethel Valley Rd., Oak Ridge, TN			
Has the owner/operator filed for a Certificate of Convenience & Necessity (CCN), or an amended CCN, with the Tennessee Regulatory Authority (TRA) (may be required for collection systems and land application treatment systems)? <input type="checkbox"/> Yes <input type="checkbox"/> No <input checked="" type="checkbox"/> N/A			
If the applicant listed above does not yet own the facility/site or if the applicant will not be the operator, explain how and when the ownership will be transferred or describe the contractual arrangement and renewal terms of the contract for operations. N/A			
Complete the following information explaining the entity type, number of design units, and daily design wastewater flow:			
<u>Entity Type</u>	<u>Number of Design Units</u>		<u>Flow (gpd)</u>
<input type="checkbox"/> City, town or county	No. of connections:		
<input type="checkbox"/> Subdivision	No. of homes:	Avg. No. bedrooms per home:	
<input type="checkbox"/> School	No. of students:	Size of cafeteria(s): No. of showers:	
<input type="checkbox"/> Apartment	No. of units:	No. units with Washer/Dryer hookups: No. units without W/D hookups:	
<input type="checkbox"/> Commercial Business	No. of employees:	Type of business:	
<input type="checkbox"/> Industry	No. of employees:	Product(s) manufactured:	
<input type="checkbox"/> Resort	No. of units:		
<input type="checkbox"/> Camp	No. of hookups:		
<input type="checkbox"/> RV Park	No. of hookups:	No. of dump stations:	
<input type="checkbox"/> Car Wash	No. of bays:		
<input checked="" type="checkbox"/> Other			
Describe the type and frequency of activities that result in wastewater generation. Existing single vault toilet facility at 2 security vehicle portals used 24-7 by security staff			

Engineering Report (required for collection systems and/or land application treatment systems):	<input checked="" type="checkbox"/> N/A
<input type="checkbox"/> Prepared in accordance with Rule 0400-40-05-.03 and Section 1.2 of the State of Tennessee Design Criteria for Sewage Works	
<input type="checkbox"/> Attached, or	
<input type="checkbox"/> Previously submitted and entitled:	Approved? <input type="checkbox"/> Yes. Date: <input type="checkbox"/> No
Operation and Maintenance Inspection Schedule Submitted:	Approved? <input type="checkbox"/> Yes. Date: <input type="checkbox"/> No

Wastewater Collection System:	<input checked="" type="checkbox"/> N/A	
System type (i.e., gravity, low pressure, vacuum, combination, etc.):		
System Description:		
Describe methods to prevent and respond to any bypass of treatment or discharges (i.e., power failures, equipment failures, heavy rains, etc.):		
In the event of a system failure describe means of operator notification: Contact Laboratory Shift Sup.		
List the emergency contact(s) (name/phone):		
For low-pressure systems, who is responsible for maintenance of STEP/STEG tanks and pumps or grinder pumps (list all contact information)?		
Approximate length of sewer (excluding private service lateral):		
Number/hp of lift stations:	/ Number/hp of lift pumps /	
Number/volume of low pressure and or grinder pump tanks	/	
Number/volume septic tanks	/	
Attach a schematic of the collection system. <input type="checkbox"/> Attached		
If this is a satellite sewer and you are tying in to another sewer system complete the following section, listing tie-in points to the sewer system and their location (attach additional sheets as necessary):		
<u>Tie-in Point</u>	<u>Latitude (xx.xxxx°)</u>	<u>Longitude (xx.xxxx°)</u>

Land Application Treatment System:	<input checked="" type="checkbox"/> N/A
Type of Land Application Treatment System: <input type="checkbox"/> Drip <input type="checkbox"/> Spray <input type="checkbox"/> Other, explain:	
Type of treatment facility preceding land application (recirculating media filters, lagoons, other, etc.):	
Attach a treatment schematic. <input type="checkbox"/> Attached	
Describe methods to prevent and respond to any bypass of treatment or discharges (i.e., power failures, equipment failures, heavy rains, etc.):	
For New or Modified Projects: Name of Developer for the project:	
Developer address and phone number:	
For land application, list: Proposed acreage involved: Inches/week gpd/sq.ft loading rate to be applied:	
Is wastewater disinfection proposed?	
<input type="checkbox"/> Yes Describe land application area access:	
<input type="checkbox"/> No Describe how access to the land application area will be restricted:	
Attach required additional Engineering Report Information (see website for more information)	
<input type="checkbox"/> Topographic map (1:24,000 scale presented at a six inch by six inch minimum size) showing the location of the project including quadrangle(s) name(s) GPS coordinates, and latitude and longitude in decimal degrees should also be included.	
<input type="checkbox"/> Scaled layout of facility showing the following: lots, buildings, etc. being served, the wastewater collection system routes, the pretreatment system location, the proposed land application area(s), roads, property boundaries, and sensitive areas such as streams, lakes, springs, wells, wellhead protection areas, sinkholes and wetlands.	
<input type="checkbox"/> Soils information for the proposed land disposal area in the form of a Water Resources Soils Map per Chapter 16 and 17 State of Tennessee Design Criteria for Sewage Work. The soils information should include soil depth (borings to a minimum of 4 feet or refusal) and soil profile description for each soil mapped.	
<input type="checkbox"/> Topographic map of the area where the wastewater is to be land applied with no greater than ten foot contours presented at a minimum size of 24 inches by 24 inches.	
<input type="checkbox"/> Describe alternative application methods based on the following priority rating: (1) connection to a municipal/public sewer system, (2) connection to a conventional subsurface disposal system as regulated by the Division of Groundwater Protection, and/or (3) land application.	

<p>For Drip Dispersal Systems Only: Unless otherwise determined by the Department, sewage treatment effluent wells, i.e, large capacity treatment/drip dispersal systems after approval of the SOP Application, will be issued an UIC tracking number and will be authorized as Permit by Rule per UIC Rule 0400-45-06-.14(2) and upon issue of a State Operating Permit and Sewage System Construction Approval by the Department. Describe the following:</p>	<input checked="" type="checkbox"/> N/A
--	---

The area of review (AOR) for each Drip Dispersal System shall, unless otherwise specified by the Department, consist of the area lying within a one mile radius or an area defined by using calculations under 0400-45-06-.09 of the Drip Dispersal System site or facility, and shall include, but not be limited to general surface geographic features, general subsurface geology, and general demographic and cultural features within the area. Attach to this part of the application a general characterization of the AOR, including the following: (This can be in narrative form)

- A general description of all past and present groundwater uses as well as the general groundwater flow direction and general water quality.
- A general description of the population and cultural development within the AOR (i.e. agricultural, commercial, residential or mixed)
- Nature of injected fluid to include physical, chemical, biological or radiological characteristics.
- If groundwater is used for drinking water within the area of review, then identify and locate on a topographic map all groundwater withdrawal points within the AOR, which supply public or private drinking water systems. Or supply map showing general location of publicly supplied water for the area (this can be obtained from the water provider)
- If the proposed system is located within a wellhead protection area or source water protection area designated by Rule 0400-45-01-.34, show the boundary of the protection area on the facility site plan.
- Description of system, Volume of injected fluid in gallons per day based upon design flow, including any monitoring wells
- Nature and type of system, including installed dimensions of wells and construction materials

Pump and Haul:	<input type="checkbox"/> N/A
-----------------------	------------------------------

Reason system cannot be served by public sewer: Sewer/potable water utilities not available or located nearby

Distance to the nearest manhole where public sewer service is available: See attached description.

When sewer service will be available: Not planned for these facilities

Volume of holding tank: 1000 gal. per facility

Tennessee licensed septage hauler (attach copy of agreement): Carson Crest, LLC-N-dba TNT Portable Toilets

Facility accepting the septage (attach copy of acceptance letter): City of Oak Ridge Turtle Park WW Treatment Plant

Latitude and Longitude (in decimal degrees) of approved manhole for discharge of septage: N/A

Describe methods to prevent and respond to any bypass of treatment or discharges (i.e., power failures, equipment failures, heavy rains, etc.): See attachment.

Holding Ponds (for non-domestic wastewater only):	<input checked="" type="checkbox"/> N/A
Pond use: <input type="checkbox"/> Recirculation <input type="checkbox"/> Sedimentation <input type="checkbox"/> Cooling <input type="checkbox"/> Other (describe):	
Describe pond use and operation:	
If the pond(s) are existing pond(s), what was the previous use?	
Have you prepared a plan to dispose of rainfall in excess of evaporation? <input type="checkbox"/> Yes <input type="checkbox"/> No	
If so, describe disposal plan:	
Is the pond ever dewatered? <input type="checkbox"/> Yes <input type="checkbox"/> No	
If so, describe the purpose for dewatering and procedures for disposal of wastewater and/or sludge:	
Is(are) the pond(s) aerated? <input type="checkbox"/> Yes <input type="checkbox"/> No	
Volume of pond(s): _____ gal. Dimensions: _____	
Is the pond lined (Note if this is a new pond system it must be lined for SOP coverage. Otherwise, you must apply for an Underground Injection Control permit.)? <input type="checkbox"/> Yes <input type="checkbox"/> No	
Describe the liner material (if soil liner is used give the compaction specifications):	
Is there an emergency overflow structure? <input type="checkbox"/> Yes <input type="checkbox"/> No	
<i>If so, provide a design drawing of structure.</i>	
Are monitoring wells or lysimeters installed near or around the pond(s)? <input type="checkbox"/> Yes <input type="checkbox"/> No	
<i>If so, provide location information and describe monitoring protocols (attach additional sheets as necessary):</i>	

Mobile Wash Operations:		<input checked="" type="checkbox"/> N/A
<input type="checkbox"/> Individual Operator <input type="checkbox"/> Fleet Operation Operator		
Indicate the type of equipment, vehicle, or structure to be washed during normal operations (check all that apply):		
<input type="checkbox"/> Cars	<input type="checkbox"/> Parking Lot(s):	sq. ft.
<input type="checkbox"/> Trucks	<input type="checkbox"/> Windows:	sq. ft.
<input type="checkbox"/> Trailers (Interior washing of dump-trailers, or tanks, is prohibited.)	<input type="checkbox"/> Structures (describe):	
<input type="checkbox"/> Other (describe):		
Wash operations take place at (check all that apply):		
<input type="checkbox"/> Car sales lot(s)	<input type="checkbox"/> Public parking lot(s)	
<input type="checkbox"/> Private industry lot(s)	<input type="checkbox"/> Private property(ies)	
<input type="checkbox"/> County(ies), list:	<input type="checkbox"/> Statewide	
Wash equipment description:		
<input type="checkbox"/> Truck mounted	<input type="checkbox"/> Trailer mounted	
<input type="checkbox"/> Rinse tank size(s) (gal.):	<input type="checkbox"/> Mixed tanks size(s) (gal.):	
<input type="checkbox"/> Collection tank size(s) (gal.):	Number of tanks per vehicle:	
Pressure washer: _____ psi (rated) _____ gpm (rated)		
<input type="checkbox"/> gas powered <input type="checkbox"/> electric		
Vacuum system manufacturer/model:		Vacuum system capacity: _____ inches Hg
Describe any other method or system used to contain and collect wastewater:		
List the public sewer system where you are permitted or have written permission to discharge waste wash water (include a copy of the permit or permission letter):		
Are chemicals pre-mixed, prior to arriving at wash location? <input type="checkbox"/> Yes <input type="checkbox"/> No		
Describe all soaps, detergents, or other chemicals used in the wash operation (attach additional sheets as necessary):		
Chemical name:	Manufacturer:	Primary CAS No. or Product No.

**UT-Battelle, LLC
Oak Ridge National Laboratory
Environmental Protection Services Division
Vault Toilet Information**

UT-Battelle, LLC (UT-Battelle) manages operations at the Department of Energy's (DOE) Oak Ridge National Laboratory (ORNL). Two of the main ORNL vehicle entry security portals located on Bethel Valley Road are equipped with vault toilets. These vault toilet facilities were provided circa 2014 for the security personnel who staff these portals 24-7 and for individuals who may be detained while awaiting permission for access to the facilities at ORNL.

The security portal vault toilets are single unit (1000-gallon concrete vault) systems that were purchased from a supplier of pre-constructed vault facilities (CXT Concrete Buildings). The concrete vaults have a liner system installed by the manufacturer. The placement of each of the vault toilets involved minimal on-site construction to install and to render the toilets operational. There is no sanitary or water connection supplied to these vault toilets due to the remote location and expense of supplying these utilities. These vault toilet facilities are intended to be permanent in that there are no plans to supply utility connections to build more traditional restrooms. The west portal is approximately 0.75 miles from the nearest sanitary connection; the east portal is approximately 3.5 miles away from the nearest sanitary connection. UT-Battelle security staff access the facilities daily. Janitorial staff re-stock supplies and clean the facilities daily using general-purpose cleaners and disinfectants that are wiped down after being applied. There are no plans to clean the vault toilets using a water spray or free liquids that require collection or management. The units are configured for accumulation of septic waste in the vault tank which is pumped out every 2 weeks in spring/summer and once per month in fall and winter by a third-party pump and haul (P&H) vendor (Carson Crest, LLC-N-dba TNT Portable Toilets in Oliver Springs, TN; Permit No. 290). In the infrequent instances where the toilets require more frequent emptying, the P&H vendor is engaged with a standing purchase order to mobilize when needed. In the unlikely event of a spill, UT-Battelle staff overseeing the P&H activities would notify the ORNL Laboratory Shift Superintendent's Office who would activate the UT-Battelle spill response team (SRT) to isolate/mitigate and clean up the spill. Once the septic waste is collected by the P&H vendor, the vendor, along with the receiving treatment facility (City of Oak Ridge Turtle Park Wastewater Treatment Plant), assume the responsibility to ensure that bypass of treatment or untreated discharge to the environment does not occur.

Engineering drawings, applicable specifications and other applicable literature for a single unit vault toilet have been included with this application. As requested in the TDEC meeting minutes dated 6/2/2022, the plans and specifications will be submitted separately for review and approval by the TDEC Engineering Services Unit. Licensing and septic disposal approval information on the P&H vendor has also been provided as required in this application. Future installations of remote vault toilet facilities or other collection tanks may be considered as research footprints expands within the ORNL reservation.

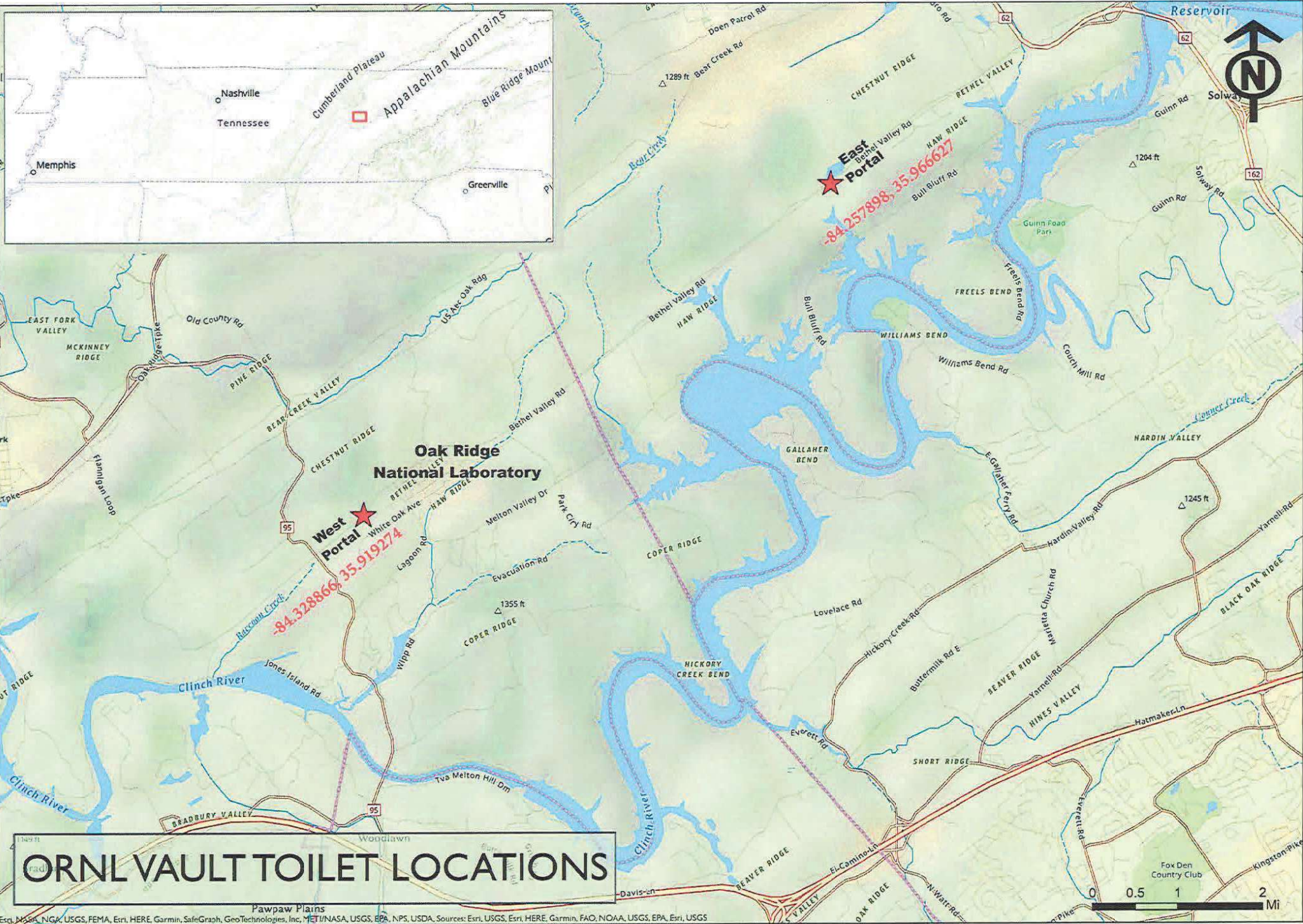

ORNL VAULT TOILET LOCATIONS

Map data: © 2023 Google, NGA, USGS, FEMA, Esri, HERE, Garmin, SafeGraph, GeoTechnologies, Inc., METI/NASA, USGS, EPA, NPS, USDA, Sources: Esri, USGS, Esri, HERE, Garmin, FAO, NOAA, USGS, EPA, Esri, USGS

ORNL West Portal Vault Toilet at West Security Entrance



7/27/2023, 10:30:26 AM

— Streams and Conveyances

Buildings

□ Building

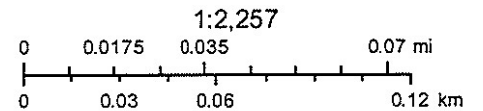

Esri, HERE, Garmin, (c) OpenStreetMap contributors, and the GIS user community

ORNL East Portal Vault Toilet at East Security Entrance

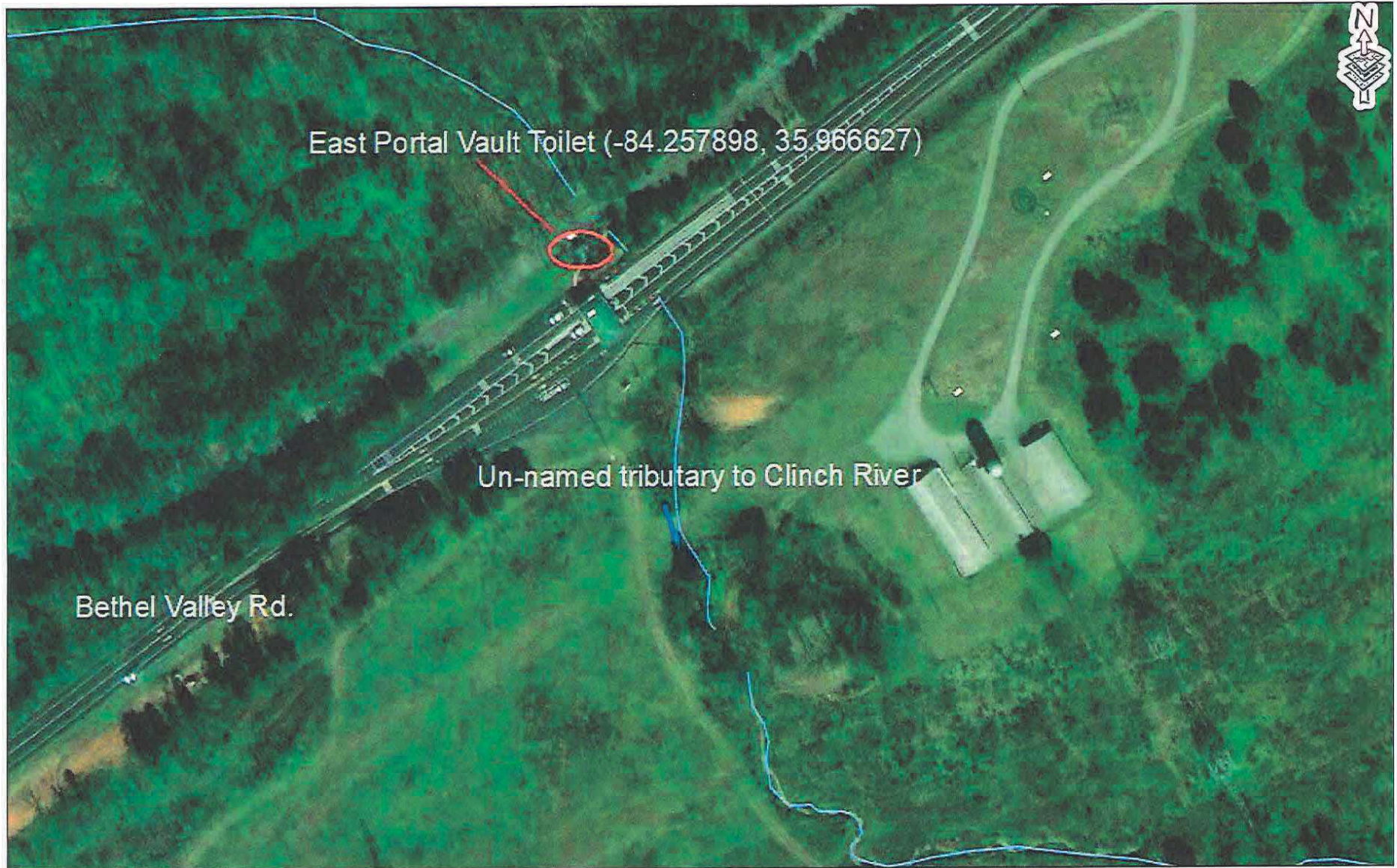

7/19/2023, 1:57:09 PM

- Streams and Conveyances
- Building Yard Area
- Buildings
- Surface Water
- Building

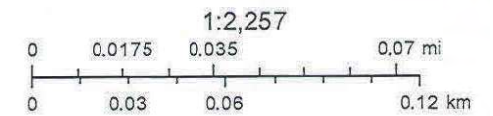

Esri, HERE, Garmin, (c) OpenStreetMap contributors, and the GIS user community

TN Licensed Septage Hauler Agreement



STATE OF TENNESSEE
DEPARTMENT OF ENVIRONMENT AND CONSERVATION
DIVISION OF WATER RESOURCES

PERMIT FOR SEPTIC TANK PUMPING CONTRACTOR

2023

PERMIT NUMBER: 290

CARSON CREST, LLC-N-dba TNT PORTABLE TOILETS
7024 KNOXVILLE HWY, PBX 406
OLIVER SPRINGS, TN 37840

IS HEREBY GRANTED PERMISSION TO OPERATE

By The Tennessee Department of Environment And Conservation In
Accordance With The Provision Of The Regulations To Govern
Subsurface Sewage Disposal Systems Rule 1200-1-6-.18 As
Authorized By Tennessee Code Annotated 68-221-403(a)(7).

for

Brad Harris, Manager Land Based Unit

This permit is good until suspended or revoked by the Tennessee
Department of Environment and Conservation and automatically
becomes invalid on January 1, 2024. This permit is not
transferable or assignable.



ORNL SAP | Accounting | Employee Self-Service | HR | Materials Management | Reports | Training | Travel | Workflow | Help

Purchase Order 4000204572

[Switch to summary view](#)

General Info

Vendor 246385 CARSONCREST LLC	Order Type PO-Commercial <\$250K	Competition Code NON-COMPETITIVE SB <= \$250K	Date Created 11/07/2022
Buyer 36 Chase Stoffell	Buyer Phone 865-341-2277	Buyer FAX	Buyer E-Mail b9s@ornl.gov
Description Portable Toilet Pumping Service		Print Format Purchase Order	Performance Term Incentive No
Period of Performance 11/01/2022 - 10/31/2023	Subcontractor-Held Property No	Closeout Status ACTIVE	License Agreement No
Incremental Funding Date			

Funded Value:

Total Value: 6,000.00

Option Value:

Total Value Incl Options:

Attachments

None

General Information

Terms and Conditions # Purchase Order Commercial Items & Services Under Simplified Acquisition Threshold # BSD-CS-2154 (04/14/2022)
 Technical Direction The clause, Technical Direction (Jan 2006), is incorporated by reference and amended as follows: "Performance under this subcontract is subject to the technical direction of the Company's Technical Project Officer (TPO):" TPO Name: Jessica Lang
 staff TPO Telephone #: 865-241-4752 TPO Email Address: langstaffjb@ornl.gov
 PAYMENT INFORMATION a.) Payment Terms: The payment terms are Net 15 Days # no discount. b.) Electronic Funds Transfer (EFT): Electronic Funds Transfer (EFT) expedites payments to subcontractors and is our preferred method of payment. A remittance notification (email or fax) is automatically generated to you at the time of payment. To sign up for EFT, revise your banking information, or contact us to verify your current payment information, visit our website at <https://contracts.ornl.gov/> in the "Electronic Funds Transfer" section. c.) Ariba Network for Suppliers: For detailed p

Payment information or inquiries concerning invoices and payments please access the Ariba Network account for your organization at <https://supplier.ariba.com/> or email your questions to ornlap@ornl.gov. d.) Place of Performance: All work hereunder shall be performed at the reference filed above Primary Performance Location and other locations as mutually may be agreed upon by Company and Seller
 . COVID-19 RELATED ORNL SITE ACCESS RESTRICTIONS, FACE COVERINGS ON CAMPUS, TPO GUIDANCE, AND TRAVEL RESTRICTIONS FOR WORK PERFORMED UNDER UT-BATTELLE, LLC AGREEMENTS (July 2022) Exemption from Application of the Service Subcontract Act - Maintenance, Calibration, or Repair of Certain Equipment - Requirements (Jan 2008)[2022-11-07T17:59:58Z-b9s] Portable Toilet Pumping Service

General Provisions

General Terms and Conditions - Purchase Order Commercial Items & Services Under Simplified Acquisition Threshold (POCI November 11, 2020)

Item 1. Portable Toilet Pumping for East and West

<i>Expected Deliv Date</i>	<i>Quantity</i>	<i>Unit Price</i>	<i>Extended Price</i>	<i>Material Group</i>
10/31/2023	6,000.000 USD	1.00	6,000.00	10 Rental - Equipmen

Goods Recipient/Invoice Approver
00962913 Jessica B Langstaff

Unloading Point/Task Auth.
2519 315

GL Account
42000650

WBS Element
3126SSCO Sewage Collection (Indirect (not OH))

Agency
MAC & Responsible Person
X03 025506 Jimmy E Stone

IAN
IAN Exp. Date

Electrical Item
No

NRTL-Listed
N/A

Tracking No.

Vendor Part No.

Requisition Item
3400402368-00001

MSDS

Tax Description
Tennessee State Tax - A/P

Inspection Required
No

Quality - Significant
No

ES&H Review Required
Yes

Invoice Approval Required
No

Tax Calculation
Fully Taxable

Qty Received

Value Received

Last Receipt Date

Goods Receipt Indicator

Qty Invoiced

Value Invoiced

Last Invoice Date

Item Text/SOW/Specification

Portable Toilet Pumping for East and West portal toilets and 7014 septic tank.

Document Reviews

HMIS Review Not required

Approvals

Type	Status	Approvers	Date	Time
Ariba Auto Approval	Auto-approved	ACI	11/07/2022	13:42:10
Ariba Auto Approval	Approved	ACI	11/07/2022	13:42:11
Ariba Auto Approval	Auto-approved	ACI	11/07/2022	13:42:15

[Reload page with texts in fixed-width font \(to improve display of tables\)](#)

[Switch to summary view](#)

[ORNL SAP](#) | [ORNL Internal](#) | [Questions](#) | [Disclaimers](#)

Powered by *ORNL SAP*

Facility Accepting Septage (Acceptance Letter)

CITY OF OAK RIDGE



POST OFFICE BOX 1 • OAK RIDGE, TENNESSEE 37831-0001

January 27, 2022

Mrs. Jean Carson
TNT Portables
P.O. Box 406
Oliver Springs, TN 37840

Subject: Approved Septic Disposal Extension Letter

Dear Mrs. Carson,

This letter is to notify you that after careful consideration, the City of Oak Ridge has decided to grant TNT Portables a temporary extension for approved septic waste disposal at Turtle Park Wastewater Treatment Plant under the following conditions:

1. All septic waste generated for disposal shall be comprised of only domestic waste from portable toilets or toilet trailers located in Oak Ridge, TN, and that fall under current federal contracts only. No industrial waste, or waste generated from any other facilities will be accepted without prior approval. These contracts from: ARS, ATKINS, BES, BESCO, CTI, East Tennessee RR, Gemtech, Global GO, Ivey Mechanical, Johnson Control (Y12), OR Hardwoods, OR City (and Electric), Peloton, Perma Fix, Rogers/Rogers Group (Y12 Only), Service Electric, TN Electric, TN Wildlife, TVA, UT Battelle, Walker, and CNS will be the only contracts accepted for waste disposal at the Turtle Park Wastewater Treatment Plant.
2. All septic waste generated must be disposed of during the hours of 7 a.m. and 5 p.m. Monday-Friday, and will be limited to no more than two trucks per day.
3. All septic trucks must be clearly marked with an "TNT Portables" logo. Sub-contractor trucks will not be allowed to dispose of waste material under this approval letter.
4. This approval letter must be present in each septic truck.
5. Disposal will only be allowed at the designated manhole near the Turtle Park Wastewater Treatment Plant. No disposal at Rarity Ridge (K-25 or ETTP) will be allowed.
6. The procedure for disposal stated below, must be followed.

Procedure for Disposal:

Upon arrival at the Turtle Park Wastewater Treatment Plant (WWTP) designated manhole, the septic truck driver must call the WWTP at 865-425-1642. A designated WWTP employee will meet the driver at the manhole, unlock the manhole, visually observe the disposal of the septic waste, sample the waste material as needed, and lock the manhole after waste has been discharged. The septic truck driver must complete a manifest after each disposal load, and immediately submit the paperwork at the designated location in the hallway of the WWTP. No waste shall be disposed of without the presence of a WWTP employee.

Please note that this letter serves only as a temporary extension of the termination letter dated November 16, 2021. All rules and regulations regarding septic waste disposal are subject to modification, or termination as the City continues to seek resolutions for its septic waste hauling program. As an industrial user, you are subject to comply with the City's Sewer Use Ordinance 18-11. If you have any additional questions, please contact us.

Regards,



Patrick Berge, P.E.
Public Works Director

Muhs, Lori

From: Bailey, Miller R <mrbailey@oakridgetn.gov>
Sent: Tuesday, December 6, 2022 12:33 PM
To: Muhs, Lori
Subject: [EXTERNAL] RE: Copy of Acceptance Letter for Septic Disposal

Lori,

Unfortunately we do not have any updated paperwork in regards to TNT portables. We are currently working with TDEC to develop a permitting program for our plant. Once this is complete, we will release the permitting application to TNT for them to fill out with their most up to date contracts and dumping schedule. We will be happy to include you all for feedback to make sure the contract dates and dumping schedules are accurate as well.

Miller Bailey
Environmental Compliance Inspector | City of Oak Ridge
P (865) 425-1829 | E mrbailey@oakridgetn.gov
[@CityOfOakRidge](https://www.cityofoakridge.gov) | [oakridgetn.gov](https://www.oakridgetn.gov)



From: Muhs, Lori <muhs1a@ornl.gov>
Sent: Monday, December 5, 2022 2:49 PM
To: Berge, Patrick <pberge@oakridgetn.gov>
Cc: Bailey, Miller R <mrbailey@oakridgetn.gov>
Subject: Copy of Acceptance Letter for Septic Disposal

Good afternoon,
I have a copy of an approval letter dated January 27, 2022 from City of Oak Ridge sent to P&H vendor TNT Portables which temporarily approved septic disposal at Turtle Park Wastewater Treatment Plant. The letter is attached for your reference. I was wondering if I could get the most recent version of this approval letter, if there is one. I am preparing an SOP application package for TDEC and need to provide this information for our contracted services from TNT.

Thank you for your help,
Lori

Lori A Muhs
UTB Water Quality Compliance
Oak Ridge National Laboratory
(865) 607-9774

Electronic communications with officials and employees of the City are subject to Tennessee's Public Records Act.

Vault Toilet Specifications and Drawings

**SPECIFICATIONS
FOR ROCKY MOUNTAIN STYLE
VAULT TOILET BUILDINGS**

1.0 SCOPE

This specification covers the construction and placing of the Rocky Mountain precast concrete vault toilet building as produced by CXT.

2.0 SPECIFICATIONS

ASTM C33	Concrete Aggregates
ASTM C39	Method of Test for Compressive Strength of Cylindrical Concrete Specimens
ASTM C94	Standard Specification for Ready-Mixed Concrete
ASTM C143	Method of Test for Slump of Concrete
ASTM C150	Standard Specification for Portland Cement
ASTM A185	Standard Specification for Steel Welded Wire Reinforcement, Plain, or Concrete
ASTM C192	Method of Making and Curing Test Specimens in the Laboratory
ASTM C231	Standard Test Method for Air Content of Freshly Mixed Concrete by the Pressure Method
ASTM C309	Standard Specifications for Liquid Membrane-Forming Compounds for Curing Concrete
ASTM C494	Standard Specification for Chemical Admixtures for Concrete
ASTM A615	Standard Specification for Deformed and Plain Carbon-Steel bars for Concrete Reinforcement
ASTM C618	Standard Specification for Coal Fly Ash and Raw or Calcined Natural Pozzolan for Use in Concrete
ASTM C979	Standard Specification for Pigments for Integrally Colored Concrete
ACI 211.1	Standard Practice for Selecting Proportions for Normal, Heavyweight, and Mass Concrete
ACI 306	Cold Weather Concreting
ACI 318	Building Code Requirements Structural Concrete and Commentary (includes Errata)
PCI MNL 116	Quality Control for Plants and Production of Precast Prestressed Concrete Products

3.0 MANUFACTURER CRITERIA

The manufacturer supplying the requested precast concrete vault facility must meet the following:

- A. Manufacturer must be ISO 9001 certified at the time of bid.
- B. Manufacturing plant must be PCI certified at the time of bid.
- C. Manufacturer must not have defaulted on any contract within the last five years.
- D. Manufacturer must provide stamped, engineered drawings prior to acceptance.
- E. Manufacturer must be pre-approved prior to bidding.
- F. Manufacturer must show four examples of Sweet Smelling Technology designed precast concrete vault toilet facilities produced, installed, and in use as an example of their ability to perform on this contract.
- G. Manufacture shall provide a 20 year warranty.

Manufacturers meeting these criteria are:

CXT, Incorporated
Spokane Industrial Park
3808 North Sullivan Road, Building 7
Spokane, WA 99216
Phone: 800-696-5766

4.0 DESIGN CRITERIA

The Rocky Mountain has been designed to meet the following criteria. Calculations and Engineer's stamped drawings are available, for standard buildings, upon request by the customer and are for their sole and specific use only. The design criteria are to ensure that they not only will withstand the forces of nature listed below but will provide protection from vandalism and other unforeseen hazards. Design criteria include provisions of the 2006 IBC Code.

- A. **Roof Snow Load**
 - 1. The Rocky Mountain is designed to withstand a 350 pounds per square foot snow load.
- B. **Floor Load**
 - 1. The Rocky Mountain is designed to withstand 400 pounds per square foot floor load.
- C. **Wind Load**
 - 1. The Rocky Mountain will withstand the effects of 150 mile per hour (3-second gust) wind exposure C.

D. Earthquake

1. The Rocky Mountain will withstand the effects of a seismic design category E earthquake.

E. Additional Design Standards

1. The Rocky Mountain is designed to meet the requirements of the sixty-inch turning radius inside toilet room specified by the American with Disabilities Act Requirements and Uniform Federal Accessibility Standards as of the date of these specification.
2. The Rocky Mountain incorporates all design aspects of Sweet Smelling Technology as outlined by Briar Cook for the U.S. Forest Service.
3. The Rocky Mountain has a one-piece full length and width vault unit to support the building, screen area and snow loads evenly. The Rocky Mountain has a one-piece floor unit to prevent panels that migrate in different direction during periods of freeze/thaw stress.
4. The Rocky Mountain is an all concrete design with a minimum 7/12 roof pitch.
5. The Rocky Mountain shall have a minimum 4 inch wall, 4 ½ inch roof, and 5 inch floor thickness.
6. All wall to floor interior surface seams shall have a minimum 1" radius coving made of high strength grout.

5.0 MATERIALS

A. Concrete - General

The concrete mix design will be designed to ACI 211.1 to produce concrete of good workability.

1. Concrete will contain a minimum of 675 pounds of cementitious material per yard. Cement will be a low alkali type I/II or III conforming to ASTM C-150
2. Coarse aggregates used in the concrete mix design will conform to ASTM C33 with the designated size of coarse aggregate #67.
3. Minimum water/cement ratio will not exceed .45.
4. Air-entraining admixtures will conform to ASTM C260. Water reducing admixtures will conform to ASTM C494, Type A.
5. If Self Compacting Concrete (SCC) is used, it must conform to ASTM C1611

B. Colored Concrete

1. Color additives will conform to ASTM C979. A

12"x12"x1" color sample will be available for customer approval.

2. The following will contain colored concrete:
 - a. Toilet building roof panels
 - b. Building walls
 - c. Screen panels
3. The same brand and type of color additive will be used throughout the manufacturing process.
4. All ingredients will be weighed and the mixing operation will be adequate to ensure uniform dispersion of the color.

C. Cold Weather Concrete

1. Cold weather concrete placement will be in accordance with ACI 306.
2. Concrete will not be placed if ambient temperature is expected to be below 35 degrees F. during the curing period unless heat is readily available to maintain the surface temperature of the concrete at least 45 degrees F.
3. Materials containing frost or lumps of frozen materials will not be used.

D. Hot Weather Concrete

The temperature of the concrete will not exceed 95 degrees F. at the time of placement. When the ambient reaches 90 degrees F. the concrete will be protected with moist covering.

E. Concrete Reinforcement

1. All reinforcing steel will conform to ASTM A615. All welded wire fabric will conform to ASTM A185.
2. All reinforcement will be new, free of dirt, oil, paint, grease, loose mill scale and loose or thick rust when placed.
3. Details not shown of drawings or specified will be to ACI318.
4. Steel reinforcement will be centered in the cross-sectional area of the walls and will have at least 1 1/4" of cover on the under surface of the floor.
5. The maximum allowable variation for center-center spacing of reinforcing steel will be 1/2".
6. Full lengths of reinforcing steel will be used when possible. When splices are necessary on long runs, splices will be alternated from opposite sides of the components for adjacent steel bars. Lap bars

#4 or smaller a minimum of 12". Lap bars larger than #4 a minimum of 24 bar diameters.

7. Reinforcing bars will be bent cold. No bars partially embedded in concrete will be field bent unless approved by the customer.

F. Sealers and Curing Compounds

1. Curing compounds, if used, will be colorless, complying with ASTM C309, type I or 1-D.
2. Weatherproofing sealer for exterior of building will be a clear water repellent penetrating sealer.

H. Caulking, Grout, Adhesive and Sealer

1. Caulking service temperatures from -40 to +194 degrees Fahrenheit.
2. Interior and exterior joints will be caulked with a paintable polyurethane sealant.
3. Grout will be a non-shrink type and will be painted to match the color of surrounding concrete as nearly as possible.
4. Cement base coating is formulated with a very fine aggregate system and is a built in bonding agent.

H. Paint

1. All paints and materials will conform to all Federal specifications or be similar "top-of-the-line-components". Paints will not contain more than .06 percent by weight of lead.
2. Type of paints for toilets
 - a. Inside concrete surfaces
 - I Interior floors will be a chemical resistant urethane. The color will be gray.
 - II Interior walls and ceilings will be a modified acrylic, water repellent penetrating stain. The color will be white followed by a clear acrylic anti-graffiti sealer.
 - b. Metal surfaces both inside and out
 - I DTM ALKYD
 - c. Exterior concrete surfaces
 - I Exterior slab will be clear sealer
 - II Exterior walls and roof will be a water repellent penetrating stain in the same color as the walls or roof followed by a clear acrylic anti-graffiti sealer

I. Grab bars

Grab bars will be 18 gauge, type 304 stainless steel with 1-1/2" clearance. Grab bars will each be able to withstand 300 pound top loading.

J. Toilet Paper Dispenser

Dispenser will be constructed of 1/4" thick, type 304 stainless steel. Dispenser will be capable of holding three (3) standard rolls of toilet paper. Toilet paper holder fastening system will be able to withstand 300 pound top loading.

K. Steel Doors

1. Doors will be flush panel type 1-3/4" thick, minimum 16 gauge Galvanized steel, top painted with DTM ALKYD.
2. Door frames will be knockdown or welded type, single rabbet, minimum 16 gauge prime coated steel top painted with DTM ALKYD, width to suit wall thickness. Three (3) rubber door silencers will be provided on latch side of frame.

L. Door Hinges

Door hinges will be 3 per door with dull chrome plating 4-1/2"x4-1/2", adjustable tension, automatic-closing for each door.

M. Lockset

1. Lockset will meet ANSI A156.2 Series 4000, Grade 1 cylindrical lockset for exterior door.
2. Lever handle both inside and out
3. Either handle operates latch unless outside handle is locked by inside push-button.
4. Push-button will automatically release when inside lever handle is turned or door is closed.
5. Emergency slot on exterior so door can be unlocked from the outside with a coin, screwdriver and etc.
6. Inside lever always active.
7. U.S. 26D finish.

N. Dead Bolt

Deadbolt will be a Lori Lock standard model with a double cylinder, 2 3/4" backset, and US26D finish. The cylinder will be a standard 1 1/8" Schlage Mortise cylinder with compression ring and 626 finish.

O. Door Stop

Doorstop will be a dome style stop meeting ANSI 156.16.

P. Double Coat Hook

Coat hook will be 304 stainless steel 16 gauge (1.5mm), formed construction with a satin finish and have 3/16"x 7/8" nail in anchor. Upper hook will extend at least 2-1/2" inches from the wall. Lower hook will extend at least 1-1/4" from the wall.

Q. Door Sweep

Door sweep will be provided at the bottom of door and will be an adjustable brush type.

R. Wall Vent

Vent cover will be 14 gauge 304 stainless steel painted with DTM and anchored into the concrete wall with high strength anti-rust tap con fasteners. The vent louver frame and louvers will be non-vision .1" extruded aluminum jet coat finish. Vent to come with insect screen. Cover to be recessed a minimum 3/4" on exterior walls with a 45 degree bevel. Interior to be flush mounted. Wall vent will not protrude from the wall.

S. Signs

1. Signs to have raised pictograms, letters and Braille to meet ADA.
2. Interior to have "No Trash in Vault Sign".
3. All signs inset a minimum of 3/4" into wall with 45 degree bevel.
4. All signs to be anchored into concrete with 1/4" x 3/4" concrete anchor nails.

T. Windows and Vault Cleanout Cover

1. Windows and cleanout cover frames will be constructed from steel.
2. Window glazing will be 3/16" thick translucent pebble finished mar-resistant Lexan.
3. Plate for vault cleanout cover will be 1/4" thick diamond plate steel. Lid will be hinged and configured so that it can be locked with a padlock. A gasket will be provided around the entire perimeter of the lid to provide an airtight seal.
4. Windows to have 3/4" recess with 45 degree bevel.
5. Windows frames to have vandal resistant fasteners.

U. Vent Stack

Vent stack to be a minimum 12 inches in diameter and a minimum 3 feet higher than the roof peak.

V. Vault Liner

The vault liner shall be made from a single sheet black ABS/750 virgin plastic and can hold up to 1,000 gallons of waste or 15,000 uses per vault. The initial sheet thickness shall be a minimum .375. Final stamped thickness shall be a minimum .060. The vault liner shall have molded dovetail embeds to attach the liner to concrete walls of the vault. The vault liner shall have two J-rails to attach the liner to the bottom of the vault. Vaults with ABS liner shall be warranted against leaks for a period of seven years.

W. Riser

Riser will meet ADA and be a molded one piece HDPE Aquatuf®. Riser will be a smooth surface and have high impact resistance at extremely cold temperatures.

X. Optional Roof Insulation

Ceiling anchored ½" plywood + fiberglass laminate + 2" polyurethane foam. Approximately R-19.

6.0 MANUFACTURE

A. Mixing and Delivery of Concrete

Mixing and delivery of concrete will be in accordance with ASTM C94, section 10.6 through 10.9 with the following additions:

1. Aggregate and water will be adjusted to compensate for differences in the saturated surface-dry condition.

B. Placing and Consolidating Concrete

Concrete will be consolidated by the use of mechanical vibrators. Vibration will be sufficient to accomplish compaction but not to the point that segregation occurs.

C. Finishing Concrete

1. Interior floor and exterior slabs will be floated and troweled.
2. All exterior building walls and exterior screen walls will be any one of the available textures.

3. All exterior surfaces of the roof panels will be cast to simulate any one of the available textures. The underside of the overhang will have a smooth finish.

D. Cracks and Patching

1. Cracks in concrete components which are judged to affect the structural integrity of the building will be rejected.
2. Small holes, depressions and air voids will be patched with a suitable material. The patch will match the finish and texture of the surrounding surface.
3. Patching will not be allowed on defective areas if the structural integrity of the building is affected.

E. Curing and Hardening Concrete

1. Concrete surfaces will not be allowed to dry out from exposure to hot, dry weather during initial curing period.

7.0 FINISHING AND FABRICATION

A. Structural Joints

1. Wall components will be joined together with two welded plate pairs at each joint. Each weld plate will be 6" long and located one pair in the top quarter and one pair in the bottom quarter of the seam. Weld plates will be anchored into the concrete panel and welded together with a continuous weld. The inside seams will be a paintable caulk. The outside seams will use a caulk in a coordinating building color or clear.
2. Walls and roof will be joined with weld plates, 3"x6" at each building corner.
3. The joint between the floor slab and walls will be joined with a grout mixture on the inside, a matching colored caulk on the outside and two weld plates 6" long per wall.

B. Painting/Staining

1. An appropriate curing time will be allowed before paint is applied to concrete.
2. Some applications may require acid etching. A 30% solution of hydrochloric acid will be used, flushed with water and allowed to thoroughly air dry.
3. Painting will not be done outside in cold, frosty or damp weather.
4. Painting will not be done outside in winter unless the temperature is 50 degrees F. or higher.
5. Painting will not be done in dusty areas.

6. All surface voids to be filled prior to painting
7. Schedule of finishes
 - a. Inside concrete surfaces
 - I Inside floors will be 1 coat of 1-part water based chemical resistant urethane.
 - II Interior walls and ceilings will be 2 coats of a modified acrylic, water repellent penetrating stain, followed by 1 coat of clear sealer.
 - b. Metal surfaces both inside and out
 - I 2 coats of DTM ALKYD
 - c. Exterior concrete surfaces
 - I Exterior walls will be 2 coats of water repellent penetrating stain in the same color as the walls or roof followed by 1 coat of clear acrylic anti-graffiti sealer.

8.0 TESTING

The following tests will be performed on concrete used in the manufacture of toilets. All testing will be performed in the CXT (PCI certified) laboratories. Testing will only be performed by qualified individuals who have been certified ACI Technician Grade 1. Sampling will be in accordance with ASTM C172.

1. The air content of the concrete will be checked per ASTM C231 on the first batch of concrete. The air content will be in the range of 5.0% +/- 2.0%.
2. The compressive strength of the cylinders will be tested to ASTM C39. We will make one (1) cylinder for release, one (1) for 7-days and one (1) for 28-days. The release must be a minimum strength of 2500 psi, the 7-day must be a minimum of 4500 psi and the 28-day must be a minimum of 5000 psi.
3. A copy of all test reports will be available to the customer as soon as 28-day test results are available.

9.0 INSTALLATION

A. Scope of Work

Work specified under this Section includes excavation, backfill and placement of precast concrete vault toilet.

B. Materials

1. Bedding material to be sand or 3/8" minus crushed or screened aggregate.
2. Caulking between vault and toilet floor to be 1"x1" Butyl tape designed specifically to bond precast concrete to precast concrete.

C. Location

It's the responsibility of the customer to:

1. Provide exact location by stakes or other approved method
2. Provide clear and level site free of overhead and/or underground obstructions
3. Provide access to the site for truck delivery and sufficient area for the crane to install and the equipment to perform the contract requirements.

D. Access to Site

Delivery to site made on normal highway trucks and trailers. If at the time of delivery conditions of access are hazardous or unsuitable for truck and equipment due to weather, physical constraints, roadway width or grade, CXT may require an alternate site with better access provided to ensure a safe and quality installation.

E. Excavation and Elevation

1. Comply with all applicable OSHA Standards for excavation.
2. Excavate for the installation of the toilet vault to a depth that will allow the structure site to be free draining after installation is completed. Allow for a 2" leveling course beneath the toilet vault. Stockpile topsoil in a separate pile at sites.
3. Finish floor elevation will be 4-6 inches above natural grade measured at the front (entrance) of the exterior slab unless otherwise approved by the customer. Ideally, the back of the building should be slightly higher to allow water to freely drain out of the toilet rooms. The customer may specify a finish floor elevation for buildings at some sites. The contractor will install buildings at these sites with the floor elevation within a plus or minus 0.05 feet of the specified floor elevation.
4. No excavation will be left open more than seven days unless otherwise approved by the customer.
5. All excavations left open overnight will be fenced with wire mesh or plastic mesh fence secured to steel posts all around the excavation.
 - a. The bottom of the fence will generally follow the contour of the ground.
 - b. Maximum spacing of the steel posts will be ten feet.
 - c. Minimum height of the fence will be 36 inches.

F. Backfill and Compaction

1. Compact the natural ground at the bottom of the vault excavation with a minimum of three passes with a whacker-type mechanical compactor or equivalent approved by the customer.
2. Install sand or aggregate bedding material for leveling course if needed. Compact leveling course with one pass with a whacker-type mechanical tamper or equivalent approved by the customer. Grade leveling course so there will be no high spots in the middle of the vault bottom. Compact with a second pass with a whacker or approved equivalent tamper.
3. Set vault in place and check for level or appropriate scope. Backfill around structure. Use excavated material for backfill except those rocks larger than six inches in maximum dimension shall not be placed within six inches of the exterior vault walls.
4. Fill, adjacent to the building entry, will have excavated material placed in eight inch loose lifts and compacted with a minimum of two passes with a whacker-type mechanical compactor or equivalent approved by the customer.

G. Finish Grading

1. Spread excess excavated material from the vault around structure. Intended final grade is flush with the top of the front slab. Allow for placement of topsoil to reach that grade. Grade backfill away from structure at maximum slope of five (5) percent unless otherwise approved by the customer.
2. Spread stockpiled topsoil as final layer after rough grading is completed. Areas disturbed by excavation, backfilling and stockpiling of excavated materials will be hand raked to remove exposed rocks over one inch in maximum dimension. Oversized rocks removed from the surface shall be disposed of in a designated area within 200 feet of the site.

I. Vault Toilet Riser and Accessories

1. Polyurethane caulk will be applied between toilet riser flange and concrete floor before the toilet riser is installed.

I. Exhaust Pipe Installation

1. After exhaust pipe is installed, seal around pipe at top and underside of roof with polyurethane caulk. Seal around pipe at top of slab will be accomplished by using polyurethane caulk.

10.0 WARRANTY—PRECAST DIVISION

CXT provides a warranty against defects in material or workmanship for a period of twenty (20) years on all concrete components. The warranty is valid only when concrete is used within the specified loadings. Furthermore, said warranty includes only the related material necessary for the construction and fabrication of said concrete components. All other non-concrete components will carry a one (1) year warranty. CXT warrants that all goods sold pursuant hereto will, when delivered, conform to specifications set forth above. Goods shall be deemed accepted and meeting specifications unless notice identifying the nature of any non-conformity is provided to CXT in writing within the specified warranty. CXT, at its option, will repair or replace the goods or issue credit for the customer provided CXT is first given the opportunity to inspect such goods. It is specifically understood that CXT's obligation hereunder is for credit, repair or replacement only, F.O.B. CXT's manufacturing plants, and does not include shipping, handling, installation or other incidental or consequential costs unless otherwise agreed to in writing by CXT.

This warranty shall not apply to:

1. Any goods which have been repaired or altered without CXT's express written consent, in such a way as in the reasonable judgment of CXT, to adversely affect the stability or reliability thereof;
2. To any goods which have been subject to misuse, negligence, acts of God or accidents or
3. To any goods which have not been installed to manufacturer's specifications and guidelines, improperly maintained, or used outside of the specifications for which such goods were designed.

11.0 DISCLAIMER OF OTHER WARRANTIES

The warranty set forth above is in lieu of all other warranties, express or implied. All other warranties are hereby disclaimed. CXT makes no other warranty, express or implied, including, without limitation, no warranty of merchantability of fitness for a particular purpose or use.

12.0 LIMITATION OF REMEDIES

In the event of any breach of any obligation hereunder, breach of any warranty regarding the goods or any negligent act or omission or any party, the parties shall otherwise have all rights and remedies available at law; however, IN NO EVENT SHALL CXT BE SUBJECT TO OR LIABLE FOR ANY INCIDENTAL OR CONSEQUENTIAL DAMAGES.

Pressure Rating		Class 265 DR7		Class 200 DR9		Class 160 DR11		Class 130 DR13.5		Class 100 DR17		Class 80 DR21		Class 65 DR26		Class 50 DR32.5	
Nominal Pipe Size	OD Size, inches	Min. Wall, inches	Weight, lbs/ft	Min. Wall, inches	Weight, lbs/ft	Min. Wall, inches	Weight, lbs/ft	Min. Wall, inches	Weight, lbs/ft	Min. Wall, inches	Weight, lbs/ft	Min. Wall, inches	Weight, lbs/ft	Min. Wall, inches	Weight, lbs/ft	Min. Wall, inches	Weight, lbs/ft
3"	3.96	0.566	2.62	0.440	2.12	0.360	1.78	0.293	1.48	0.233	1.19	0.189	0.98	0.152	0.80	0.122	0.64
4"	4.80	0.686	3.85	0.533	3.11	0.436	2.61	0.356	2.17	0.282	1.75	0.229	1.44	0.185	1.17	0.148	0.95
6"	6.90	0.986	7.96	0.767	6.43	0.627	5.39	0.511	4.48	0.406	3.62	0.329	2.97	0.265	2.42	0.212	1.95
8"	9.05	1.293	13.69	1.006	11.07	0.823	9.28	0.670	7.71	0.532	6.23	0.431	5.11	0.348	4.17	0.278	3.36
10"	11.10	1.586	20.59	1.233	16.65	1.009	13.95	0.822	11.60	0.653	9.37	0.529	7.81	0.427	6.27	0.342	5.06
12"	3.20	1.886	29.12	1.467	23.55	1.200	19.73	0.978	16.40	0.776	13.25	0.629	10.86	0.508	8.86	0.406	7.15
14"	15.30	2.186	39.12	1.700	31.64	1.391	26.51	1.133	22.03	0.900	17.80	0.729	14.59	0.588	11.91	0.471	9.61
16"	17.40	2.486	50.60	1.933	40.92	1.582	34.29	1.289	28.49	1.024	23.02	0.829	18.87	0.669	15.40	0.535	12.43
18"	19.50	2.786	63.55	2.167	51.39	1.773	43.07	1.444	35.79	1.147	28.92	0.929	23.70	0.750	19.34	0.600	15.61
20"	21.60	3.086	77.98	2.400	63.06	1.964	52.84	1.600	43.91	1.271	35.48	1.029	29.09	0.831	23.73	0.665	19.15
24"	25.80	—	—	2.867	89.96	2.345	75.39	1.911	62.64	1.518	50.62	1.229	41.50	0.992	33.86	0.794	27.32
30"	32.00	—	—	—	—	—	—	2.370	96.37	1.882	77.87	1.524	63.84	1.231	52.09	0.985	42.02
36"*	38.30	—	—	—	—	—	—	—	—	2.253	111.55	1.824	91.45	1.473	74.61	1.178	60.20
42"*	44.50	—	—	—	—	—	—	—	—	2.618	150.59	2.119	123.45	1.712	100.73	1.369	81.27
48"*	50.80	—	—	—	—	—	—	—	—	—	—	2.419	160.88	1.954	131.27	1.563	105.91
54"*	57.56	—	—	—	—	—	—	—	—	—	—	2.741	206.54	2.214	168.53	1.771	135.97
60"*	61.61	—	—	—	—	—	—	—	—	—	—	—	—	2.370	193.07	1.896	155.77

NOTES

- PolyPipe® PW Pipe is manufactured in accordance with the following standards:
 - ◆ For sizes ½" IPS through 3" IPS products are manufactured in accordance with AWWA C-901.
 - ◆ For sizes 4" IPS through 60" DIPS products are manufactured in accordance with AWWA C-906.
 - ◆ Metric sizes also available.
 - ◆ Coiled pipe available through 6" OD and straight lengths available in 40' and 50' lengths. For custom lengths, contact a Customer Service Representative.
 - ◆ Tested and certified to NSF Standard 61. *Note: Products tested and certified to NSF Standard 14 are also available upon request.*
 - ◆ Factory Mutual (FM) pipe available upon request (*Refer to A-1005 for approved sizes.*)
- Pressures are based on using water at 23°C (73.4°F) and are determined per AWWA C-901 or C-906.
- Service factors should be utilized to compensate for the effect of substances other than water and for higher temperatures.
- The above weights for IPS and DIPS sizes are calculated in accordance with Plastics Pipe Institute (PPI) TR-7, using a value of 0.955 for density.
- Available with color-coded striping.
- *Some sizes listed are special order. Call for availability on sizes.

**ABS
VAULT
LINER**

ABS VAULT LINER

Bayer Corporation -- Polymers Division



Bayer Polymers Product Guide - Properties

Product: LUSTRAN ABS

Resin: 752

Type: ABS

Description: Unreinforced, General Purpose

Highlights: Strength, Toughness, Rigidity, Heat Resistance, Dimensional Stability, Chemical Resistance, Processibility, High Gloss, High Impact, Extrusion Grade

Property	Typical Physical Properties*	Value	ASTM Test Method
General			
	Specific Gravity	1.04	D 792
	Density	0.038 lb/in ³	D 792
	Specific Volume	26.6 in ³ /lb	D 792
	Melt Flow Rate at 230°C/3.8-kg Load	1.7 g/10 min	D 1238
	Melt Flow Rate at 230°C/10-kg Load	7.7 g/10 min	D 1238
	Gloss, 60° Sheet	90%	D 523
Optical			
	Transmittance at 0.100-in Thickness	Opaque Only	D 1003
	Haze at 0.100-in Thickness	Opaque Only	D 1003
Mechanical			
	Tensile Stress at Yield	5,100 lb/in ²	D 638
	Tensile Modulus	270 lb/in ² x10 ³	D 638
	Flexural Stress at Yield	8,000 lb/in ²	D 790

ABS VAULT LINER

Flexural Modulus	270 lb/in ² x10 ³	D 790
Impact Strength, Notched Izod: 0.125-in Thickness, 73°F	6.3 ft-lb/in	D 256
Impact Strength, Notched Izod: 0.125-in Thickness, -40°F	2.2 ft-lb/in	D 256
Rockwell Hardness (R Scale)	102 R Scale	D 785
Falling Dart Impact at 50% Fail: 0.5-in Dart, 2.25-in Ring: 73°F	22 ft-lb	(Bayer)
Falling Dart Impact at 50% Fail: 0.5-in Dart, 2.25-in Ring: 0°F	18 ft-lb	(Bayer)
Falling Dart Impact at 50% Fail: 0.5-in Dart, 2.25-in Ring: -40°F	10 ft-lb	(Bayer)
Thermal		
Deflection Temperature Under Load: Unannealed, 0.125-in Thickness, 264 psi	183 °F	D 648
Deflection Temperature Under Load: Unannealed, 0.125-in Thickness, 66 psi	196 °F	D 648
Deflection Temperature Under Load: Annealed, 0.125-in Thickness, 264 psi	198 °F	D 648
Deflection Temperature Under Load: Annealed, 0.125-in Thickness, 66 psi	210 °F	D 648
Coefficient of Linear Thermal Expansion	5.2 E-05 ^b in/in/°F	D 696
Relative Temperature Index at 0.062-in Thickness: Electrical	60 °C	(UL746B)
Relative Temperature Index at 0.062-in Thickness: Mechanical with Impact	60 °C	(UL746B)
Relative Temperature Index at 0.062-in Thickness: Mechanical without Impact	60 °C	(UL746B)
Flammability^{***}		
UL94 Flame Class: 0.062-in (1.57-mm) Thickness	HB Rating	(UL94)
UL94 Flame Class: 0.125-in (3.18-mm) Thickness	HB Rating	(UL94)

* These items are provided as general information only. They are approximate values and are not part of the product specifications.

*** Flammability results are based on small-scale laboratory tests for purposes of relative comparison and are not intended to reflect the hazards presented by this or any other material under actual fire conditions.

a Properties tested in transverse direction (worst case) on 125-mil extruded sheet specimens with less than 10% orientation unless otherwise noted.

b Tested on injection molded specimen.

c Natural and black colors.

d Rating at 0.130-in (3.30-mm) thickness.

Corporate Disclaimer

The conditions of your use and application of our products, technical assistance, and information (whether verbal, written or by way of production evaluations), including any suggested formulations and recommendations, are beyond our control. Therefore, it is imperative that you test our products, technical assistance, and information to determine to your own satisfaction whether they are suitable for your intended uses and applications. This application-specific analysis at least must include testing to determine suitability from a technical as well as health, safety, and environmental standpoint. Such testing has not necessarily been done by Bayer Corporation. All information is given without warranty or guarantee. It is expressly understood and agreed that the customer assumes and hereby expressly releases Bayer Corporation from all liability, in tort, contract or otherwise, incurred in connection with the use of our products, technical assistance, and information. Any statement or recommendation not contained herein is unauthorized and shall not bind Bayer Corporation. Nothing herein shall be construed as a recommendation to use any product in conflict with patents covering any material or its use. No license is implied or in fact granted under the claims of any patent.

General / Typical Properties for Natural Resin

The data in this electronic database are provided as general information only. They are approximate values and are not part of the product specifications.

Product Usage

The products mentioned in this electronic database may be a candidate for use in any number of diverse applications, as with any product, the use of a Bayer Corporation engineering resin in a given application must be tested (including field testing, etc.) in advance by the user to determine suitability.

Flammability Information

Flammability results of the materials presented in this electronic database are based on small-scale laboratory tests for purposes of relative comparison and are not intended to reflect the hazards presented by this or any other material under actual fire conditions.

Health and Safety Information

Appropriate literature has been assembled which provides information concerning the health and safety precautions that must be observed when handling the Bayer Corporation products mentioned in this electronic database. Before working with any of these products, you must read and become familiar with the available information on their hazards, proper use, and handling. This cannot be overemphasized. Information is available in several forms, e.g., material safety data sheets and product labels. Consult your local Bayer Corporation representative or contact the Product Safety and Regulatory Affairs Department in Pittsburgh, Pennsylvania.

Regulatory Compliance Information

Some of the end-uses of the products described in this electronic database must comply with the applicable regulations, such as the FDA, NSF, USDA, and CPSC. If you have any questions on the regulatory status of any of these Bayer Corporation products, please contact your local Bayer Corporation representative or the Bayer Corporation Regulatory Affairs Manager in Pittsburgh, Pennsylvania.

ABS VAULT LINER

**Underwriters Laboratories,
Test Standard # 746B - Relative Temperature Index**

The thickness at which relative temperature index values are reported in this electronic database correspond to the thinnest specimen thickness for which a UL94 flame class rating appears in the flammability section.

Data generated from Engineering Polymers Properties Guide Brochure (Thermoplastics and Polyurethanes),
Brochure #520
Dated 5/96
Copyright © 1987, 1996 Bayer Corporation

VAULT SEALER

BUTYL TAPE

CONCRETE SEALANTS INC.

CONSEAL™

SOLVING CONCRETE
SEALING PROBLEMS.

SEAL OF SECURITY



BOND OF TRUST™

CONSEAL

CS-101

BUTYL SEALANT FOR
PRECAST STRUCTURES

APPLICATIONS

- For self-sealing joints in:
 - Concrete Vaults
 - Utility Vaults
 - Septic Tanks
 - Burial Vaults
 - Box Culverts
 - Vertical Panel Structures

SEALING PROPERTIES

- Provides permanently flexible watertight joints.
- Low to high temperature workability: 30°F to 120°F (-1°C to 48°C)
- Rugged service temperature: -30° F to +200° F (-34° C to +93° C)
- Excellent chemical and mechanical adhesion to clean dry surfaces.
- Sealed joints will not shrink, harden or oxidize upon aging.
- Controlled flow resistance for application ease.
- No priming normally necessary. When confronted with difficult installation conditions, such as wet concrete or temperatures below 40°F (4°C), priming the concrete will improve the bonding action. Consult Concrete Sealants for the proper primer to meet your application.

PHYSICAL PROPERTIES

- Specific Gravity, 77°F
 - Ductility, 77°F
 - Softening point, ring and ball °F
 - Penetration, cone 77°F, 150 gm. 5 sec.
 - Flash point, C.O.C., °F
 - Fire point, C.O.C., °F
 - Color: Black
 - Available in 36" and 42" strips and numerous roll lengths. Custom lengths available to meet your specific needs.
- | | |
|-----------|-----------------------|
| ASTM D71 | 1.35 to 1.40 |
| ASTM D113 | 10.0 cm |
| ASTM D36 | 350°F (177°C) |
| ASTM D217 | 60-70 mm |
| ASTM D92 | 450°F (232°C) minimum |
| ASTM D92 | 450°F (232°C) minimum |



CONCRETE SEALANTS INC.
8917 S. Palmer Road, P.O. Box 176, New Carlisle, Ohio 45344
(937) 845-8776 • FAX (937) 845-3587 • (800) 332-7325

**HATCH
CLEANOUT
GASKET**

CLEANOUT HATCH

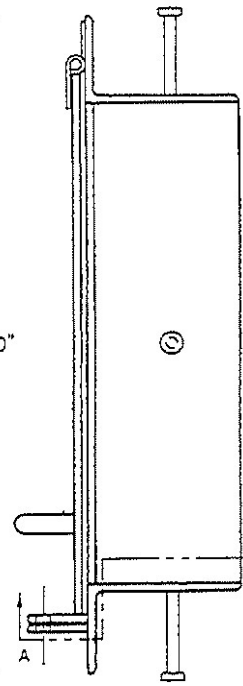
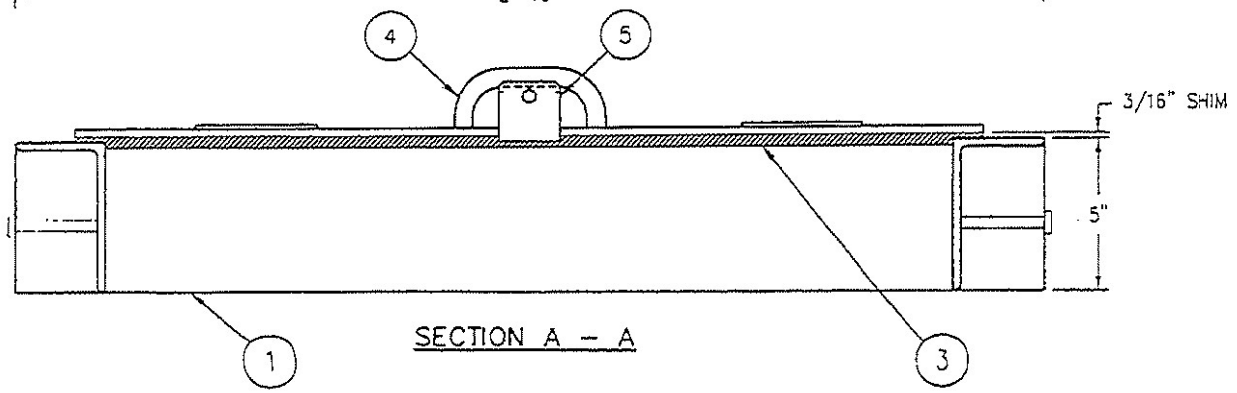
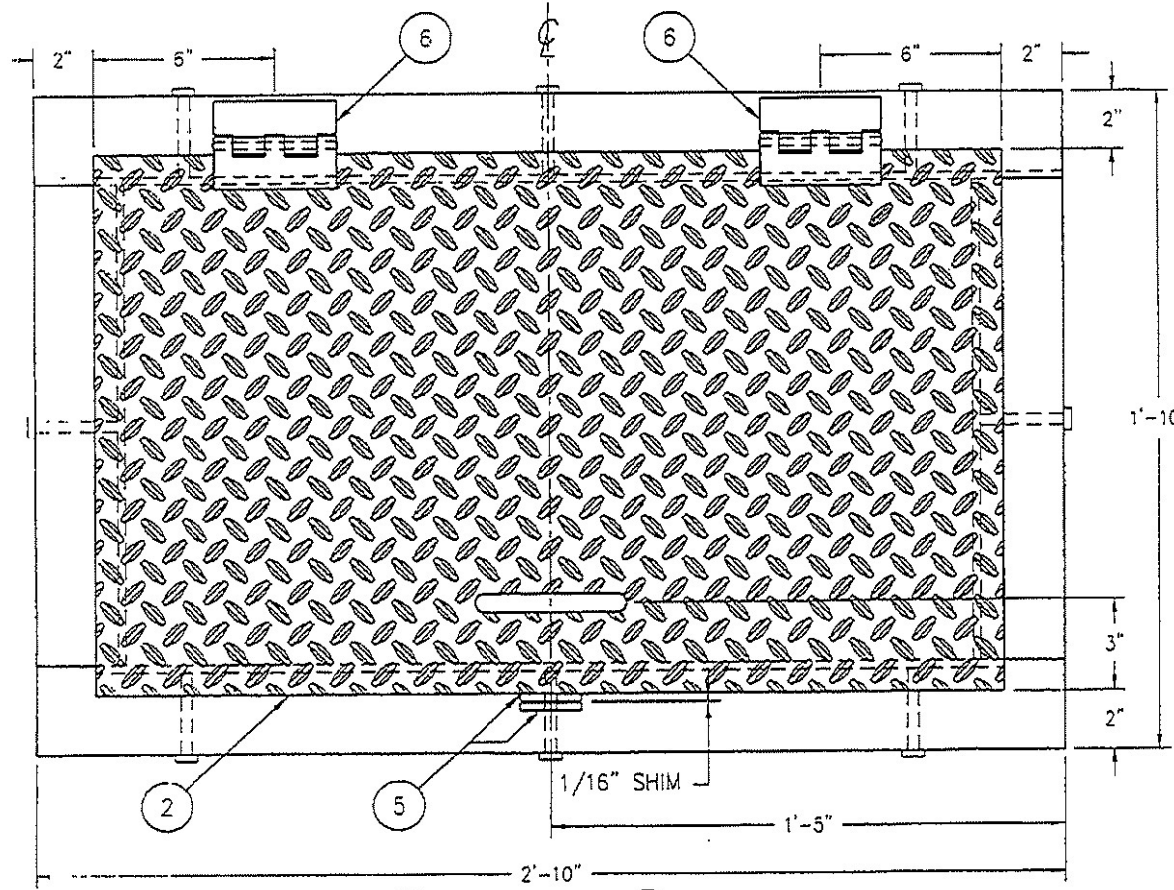

BILL OF MATERIALS		
ITEM	QTY	DESCRIPTION
1	1	HATCH FRAME ASSEMBLY (SEE DWG MS3-02)
2	1	HATCH LID ASSEMBLY (SEE DWG MS3-03)
3	1	HATCH LID GASKET (SEE DWG MS3-04)
4	1	HATCH HANDLE (SEE DWG MS3-05)
5	2	HATCH LID HASP (SEE DWG MS3-06)
6	2	4" HINGE 1 1/2" LEAF REVERSE ASSEMBLY

APPROXIMATE WEIGHT
102



Precast Products Division

PROJECT TITLE
CXT STANDARD EMBED

NOTICE

The information contained herein is proprietary and the exclusive property of CXT Incorporated. The information may only be used by the original recipient for the purpose intended. Reproduction or distribution of this information is strictly prohibited without the prior written consent of CXT Incorporated. By allowing use of this information, CXT Incorporated grants no warranty, express or implied, including a warranty of merchantability or of fitness for a particular purpose.

CXT Incorporated

A	DELETED GASKET FASTENERS	RW	04-19-00
REV.	DESCRIPTION	APPROVAL	DATE
SCALE	2" = 1'-0"	DATE	01-26-00
DRAWN	ROB D WALKER	FILE NO.	MS-3
CHECKED	[Signature]	PLOT	5

MS-3
CLEANOUT HATCH ASSEMBLY

DWG NO	SHEET	REV.
MS3-01	1 / 6	A



GE Commercial & Industrial
Electrical Distribution

100A 1φ
Outdoor Rated

Load Centers, Residential Load Centers

Product #: TM2010RCU

Short Description:



SPECIFICATIONS

Category	Single Phase - USA
Input/Output Voltage	120/240V ac
Type	Standard
Interrupting Capacity Rating	22
Amperage	100A
Device Type	Main Breaker
Enclosure	Outdoor Type 3R Enclosure
UL/CUL Listing	UL
Phase	1 Phase
1" Space	20
1/2" Space	0
Feed	Top
Door	No
GO Schedule	137D
List Price	

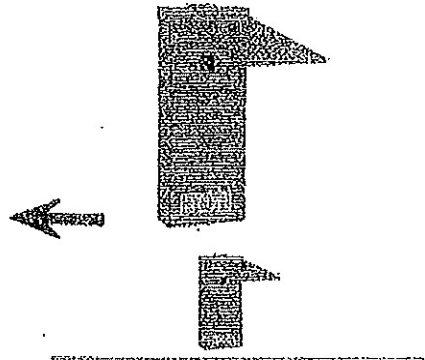

ROCKY MOUNTAIN

Single vault, fully accessible.



**Shown with Napa Valley rock and horizontal lap wall texture, and cedar shake roof texture.*

The Rocky Mountain single vault toilet building is the cutting edge of precast design with its cast in rock texture. With its steep 7 in 12 pitched simulated shake roof, large cast in windows, and unique cast in rock textures



the Rocky Mountain is the new standard in texture design. The toilet room is designed with a 60" turning radius exclusive of all fixtures, walls and doors. The Rocky Mountain comes with a single 1,000-gallon vault to hold waste.

Durability:

The Rocky Mountain is engineered and designed for long life in extreme conditions. The building meets or exceeds the effects of a Zone-4 earthquake, a 120 mph wind load and a 350 pounds per square foot snow load.

Maintenance:

The Rocky Mountain is extremely easy to maintain. With our steel reinforced 5,000 psi concrete construction, the building and vault will not rot, rust or burn. The building's interior is primed and painted with white paint to reflect natural light from the

Lexan windows mounted in heavy steel frames cast into the walls. Cleaning of the building's interior is easily accomplished with a brush and warm soapy water. The walls and roof structure are made with "colored thru concrete", which are spray coated with an exterior stain, followed by an anti-graffiti sealer.

Sweet Smelling Technology

Meets UFAS, A.D.A. and Title 24 statute of the State of California

Vandal resistant building, vault & Toilet Components

4" thick steel reinforced concrete walls

5" thick steel reinforced concrete roof & floors

A 1,000 gallon containment vault holding 15,000 uses

Concrete vault with Black plastic one piece cast in liner

Available in (25) different earthtone colors

3 rock texture options with Horizontal Lap and Board & Batt siding texture

Cedar shake and ribbed metal exterior roof texture



Vault:

The waste collecting vault is installed below ground level and is made of 4" thick reinforced concrete. The dimensions of the vault unit

matches the perimeter of the building, providing a stable footing structure that supports the

full weight of the building. The vault can hold up to 1,000 gallons of waste (15,000 uses) and is sloped, so that waste will drain to the clean out end of the vault. The vault is lined with a black plastic liner which is cast into the side walls of the concrete vault by way of dovetail embeds.

Special Features

The building can be shipped in two sections, allowing access to the most remote of sites. Additional features include texture cast concrete walls that

look like stone for the first 3 feet and texture horizontal lap or board and batt to the roof. The roof texture is cast to look like cedar shake or ribbed metal.



Sweet Smelling Technology

The building is designed with sweet smelling technology. A black plastic vent pipe, located on the back side of the building, always faces south so that when heated by the sun, the pipe creates a continual air flow through louvered vents located in the building near the floor. The air flows down the riser, through the vault, and finally, up and out of the vent pipe. The positive continual air flow carries the vault air out through

the vent pipe, not through the building, to keep the building odor free.

Quality and Value:

Because of our two state-of-the-art, 120,000 square foot production facilities, CXT can produce consistently higher quality buildings at a lower cost to meet the needs of city, county, state and federal agencies.

We at CXT take pride in our craftsmanship and are ready to provide you with our legendary customer service. See why we say, "Once you buy a CXT produced building you will never purchase anything else."



**Shown with Napa Valley rock and horizontal lap wall texture, and cedar shake roof texture.*

LB Foster

CXT® Concrete Buildings

CXT Incorporated
An L.B. Foster Company

Spokane Industrial Park
3808 N. Sullivan Road Bldg. #7
Spokane, WA 99216

Telephone 509-921-8766
Fax 509-928-8270
Toll Free 800-696-5766

www.cxtinc.com

Wall Textures: *Available Options:*



Lap Siding



Board & Batt



Napa Valley



River Rock



Flagstone

Roof Textures: *Standard:*



Cedar Shake

Available Options:



Ribbed Metal

Also available in 25 different earthtone colors.



ROCKY MOUNTAIN VAULT TOILET BUILDING

NOTES

- BUILDING IS DESIGNED TO COMPLY WITH THE 2006 INTERNATIONAL BUILDING CODE (IBC)
- DESIGN COMPLIES WITH THE PROVISIONS OF THE 2006 IBC CODE FOR THE FOLLOWING LOADS:
 GROUND SNOW LOAD = 250 PSF
 ROOF SNOW LOAD = 168 PSF
 FLOOR LOAD = 400 PSF
 IBC DESIGN SPECTRAL RESPONSE $S_s = 2.165$, $S_1 = 1.259$
 SITE CLASS D
 SEISMIC USE GROUP: I
 SEISMIC DESIGN CATEGORY: E
 BEARING WALL SYSTEM R = 4.0
 BASIC WIND SPEED = 150 MPH (3-SECOND GUST)
 WIND EXPOSURE C, I = 1.0
- BUILDING TYPE: V-B
 OCCUPANCY: U
 EXTERIOR WALLS: 1-HR RATED PER IBC TABLE 720.1(2), ITEM 4-1.1
 MINIMUM DISTANCE TO PROPERTY LINE: 10 FEET
- CONCRETE STRENGTH f'_{ci} = 2500 PSI INITIAL f'_c = 5000 PSI
 FINAL AIR ENTRAINMENT $5 \pm 1/2\%$ $\pm 1\%$ IN PLASTIC CONCRETE.
 REINFORCING STEEL: GRADE 60 $F_y = 60$ KSI
 MINIMUM LAP 18" AT SPLICES. THE BARS WITH DOUBLE ANNEALED 16 GA IRON WIRE. REINFORCING TO BE PLACED IN CENTER OF PANEL UNO. ALL BENDS IN REINFORCING SHALL HAVE A MINIMUM RADIUS OF 6x THE BAR DIAMETER.
 WELDED WIRE FABRIC(W.W.F.): 4x4xW8xW8, $F_y=65$ KSI (OR EQUIVAL)
 COMPLY WITH ASTM A82, SMOOTH WIRE, MIN. LAP 2 SQUARES.
- EMBEDDED ITEMS IDENTIFIED ON DRAWINGS (i.e. PS-2, R301)
 REFER TO CXT STANDARD EMBEDMENT CATALOG.
- BACK OF PANELS TO HAVE SMOOTH TROWEL FINISH UNO.
 ALL SURFACES TO BE TEXTURED ARE NOTED ON PANEL DWG'S
- REFER TO SEPARATE CXT INCORPORATED SPECIFICATIONS COVERING DESIGN, MATERIALS, PRODUCTION, AND INSTALLATION CRITERIA FOR SPECIFIC STYLE OF BUILDING.
- ALL REBAR BENDS ARE TO HAVE A MINIMUM RADIUS OF 6x THE BAR DIAMETER.
- INSTALLATION TO MEET APPLICABLE LOCAL, STATE & FEDERAL CODES, BY OTHERS.

PANEL MARK NO. KEY PLAN

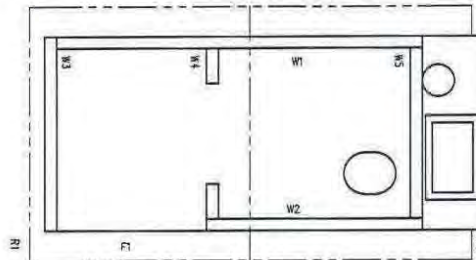

INDEX OF DRAWINGS

NO.	TITLE
RM-01	COVER SHEET
RM-02	BUILDING ELEVATIONS
RM-03	INTERIOR ELEVATIONS
RM-04	FLOOR PLAN
RM-05	FINISH DETAILS
RM-05	CASTING DETAILS
RM-07	WALL PANEL W1
RM-08	WALL PANEL W2
RM-09	WALL PANEL W3
RM-10	WALL PANEL W4
RM-11	WALL PANEL W5
RM-12	ROOF SLAB R1
RM-13	ROOF SLAB R2
RM-14	FLOOR SLAB F1, DIMENSIONS
RM-15	FLOOR SLAB F1, REINFORCEMENT
RM-16	RIGGING DETAIL
RM-17	ELECTRICAL PLAN, DETAILS & SCHEDULES
RM-18	BILL OF MATERIAL

APPLICABLE CODES

2006 INTERNATIONAL BUILDING CODE, EXCLUDING CHAPTERS 11 & 27
 2006 INTERNATIONAL PLUMBING CODE
 2006 INTERNATIONAL MECHANICAL CODE
 2008 NATIONAL ELECTRIC CODE
 TENNESSEE PUBLIC BUILDINGS ACCESSIBILITY ACT

CASTING TOLERANCES:	
OVERALL LENGTH OR WIDTH	10 FT OR UNDER = $\pm 1/8"$
	10 TO 20 FT = $\pm 1/16"$ - $3/16"$
	20 TO 40 FT = $\pm 1/4"$
TOTAL THICKNESS = $-1/8$, $+1/4$	
VARIATION FROM SQUARE = $\pm 1/8$ PER 6 FT OF DIAGONAL	
LOCAL SMOOTHNESS = $1/4"$ IN 10 FT	
SWEEP = $\pm 1/4"$	
POSITION OF HOLES = $\pm 1/4"$	
POSITION OF BLOCKOUTS = $\pm 1/4"$	
POSITION OF EMBEDS = $\pm 1/4"$	
TIPPING AND FLATNESS OF PLATES = $\pm 1/16$, $-1/4$	
BOWING = LENGTH/360	
END SQUARENESS = $\pm 1/8"$	
SELF-CORRECTING - MINIMUM COVER OF 4.5 IN	

WALL TEXTURE:	HORIZONTAL LAP / NAPA VALLEY
STONE COLOR:	MTN. BLEND
WALL COLOR:	BUCKSKIN
ROOF TEXTURE:	RIBBED METAL
ROOF COLOR:	EVERGREEN
TRIM PAINT:	DTM ALKYD ENAMEL BROWN

CXT INCORPORATED
 CONTROLLED COPY
 IF THIS DOCUMENT IS NOT APPROVED
 BY THE PROJECT MANAGER OR BY THE
 PROJECT ARCHITECT, IT IS VOID.

3030 N. Sullivan Blvd. #7 Spokane, WA 99216

CXT
Precast Products

801 N. Highway 77 Hillsboro, TX 78648

ROCKY MTN LEFT HAND
 BUILDING NUMBER RM-409

NOTICE
 The information contained herein is proprietary and the exclusive property of CXT Incorporated. The information may only be used by the original recipient for the purpose intended. Reproduction or distribution of this information is strictly prohibited without the prior written consent of CXT Incorporated. By accepting use of this information, CXT Incorporated grants no warranty, express or implied, including a warranty of merchantability or of fitness for a particular purpose.

NO.	DESCRIPTION	DATE	BY

COVER SHEET

DATE	NO.	REV.
RM-01	1	18

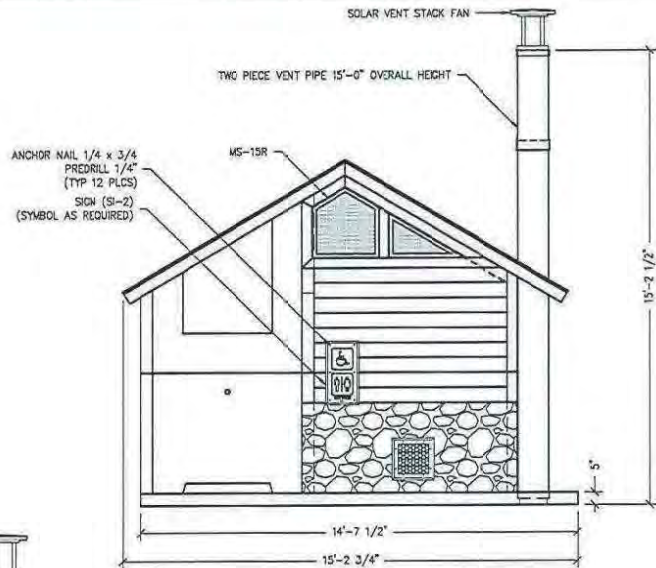

FRONT ELEVATION

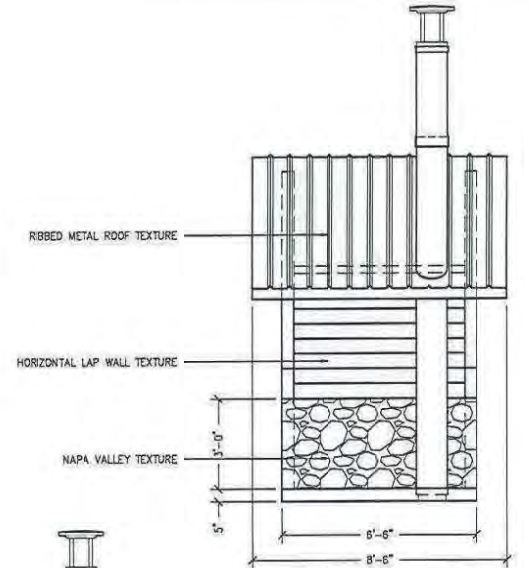

RIGHT SIDE ELEVATION

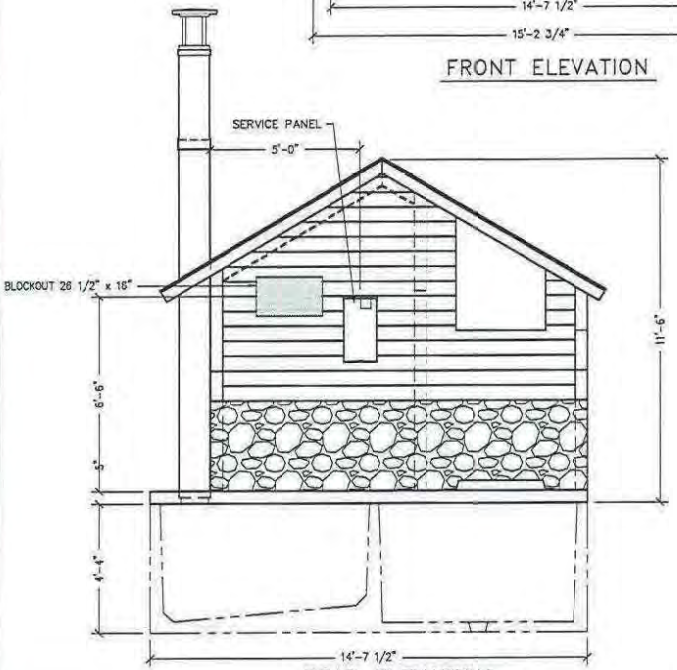

REAR ELEVATION

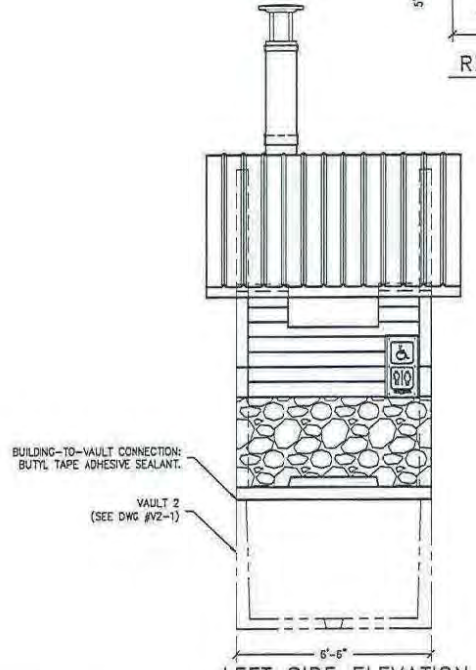

LEFT SIDE ELEVATION

EMBEDDED MATERIALS	
ITEM	QTY
VENT PIPE 3'-0"	1
VENT PIPE 12'-0"	1
ANCHOR NAIL 1/4x3/4	20
SI-2	2
MS-15R	1
SOLAR VENT STACK FAN	1

CU. FT. CONC.	SQ. FT. W.K.F.
---------------	----------------

APPROXIMATE WEIGHT

**CXT INCORPORATED
CONTROLLED COPY**
IF YOU RECEIVE A COPY OTHER
THAN THIS ONE, IT IS NOT VALID.
CALL FOR INFORMATION AT 800-875-6262

3008 N. Sullivan, Suite #7, Spicewood, TX 78226

CXT
Precast Products
801 N. Highway 77, Hillbourn, TX 75845

ROCKY MTN LEFT HAND
BUILDING NUMBER RM-409

NOTICE
The information contained herein is proprietary and the exclusive property of CXT Incorporated. The information may only be used by the original recipient for the purpose intended. Reproduction or distribution of this information is strictly prohibited without the prior written consent of CXT Incorporated. By checking use of this information, CXT Incorporated grants no warranty, express or implied, including its accuracy or completeness or of fitness for a particular purpose.

CXT Incorporated			
REV.	DATE	BY	CHKD.

BUILDING ELEVATION

DWG. NO.	SHEET	REV.
RM-02	2	18

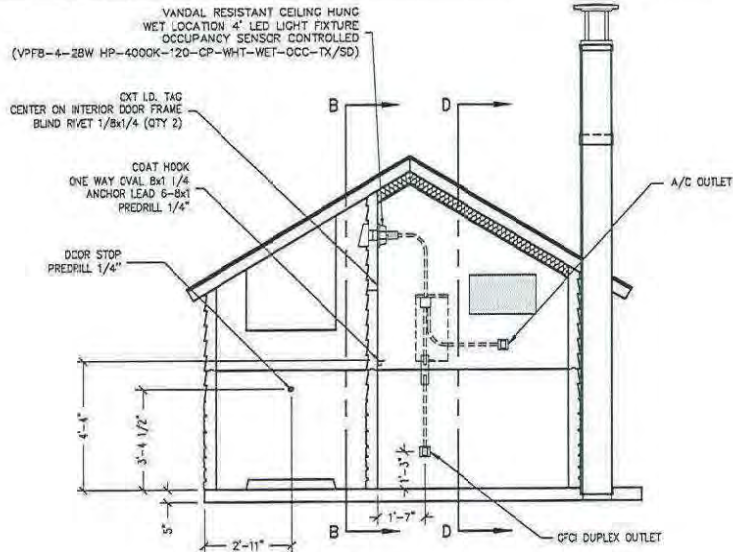

SECTION A - A

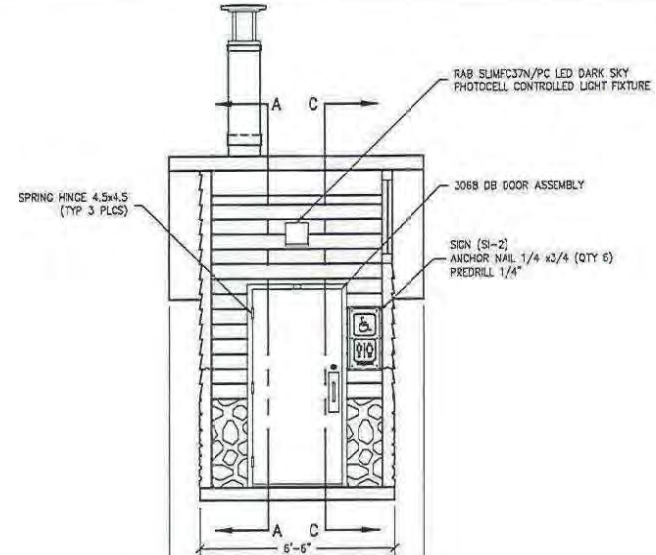

SECTION B - B

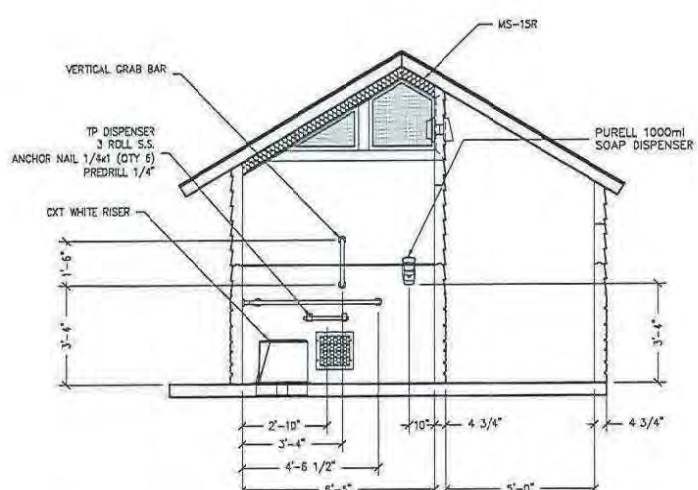

SECTION C - C

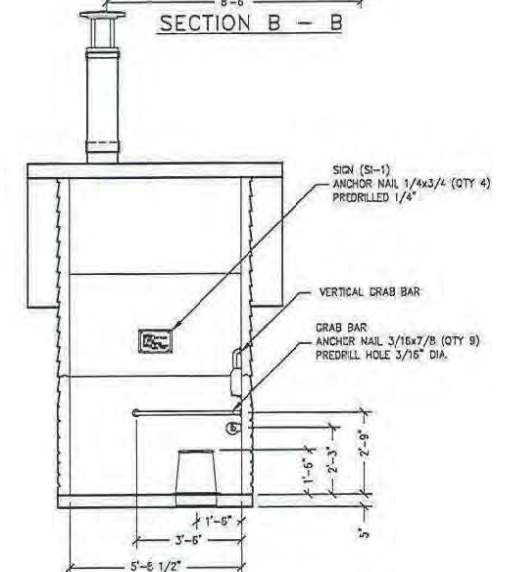

SECTION D - D

EMBEDDED MATERIALS	
ITEM	QTY
CXT WHITE RISER	1
GRAB BAR	1
TP DISPENSER	1
TOILET PAPER ROLL	3
COAT HOOK	2
DOOR STOP	1
SI-1	1
SI-2	1
CXT I.D. TAG	1
ANCHOR NAIL 1/4x1	6
ANCHOR NAIL 1/4x3/4	10
ANCHOR NAIL 3/16x7/8	15
ONE WAY OVAL 6x1/4	2
ANCHOR LEAD 6-8x1	2
BLIND RIVET 1/8x1/4	2
3068 DOOR ASSEMBLY	1
SPRING HINGE 4.5x4.5	3
VERTICAL GRAB BAR	1
PURELL SOAP DISPENSER	1

CL. FT. DDIC. SQ. FT. W.M.F.

APPROXIMATE WEIGHT

CXT INCORPORATED
CONTROLLED COPY
THIS DOCUMENT IS THE PROPERTY OF CXT INCORPORATED
IT IS TO BE USED ONLY FOR THE PROJECT AND AT THE LOCATION SPECIFIED
IT IS TO BE DESTROYED OR RECYCLED UPON COMPLETION OF THE PROJECT

3208 N. Sullivan Blvd., P.O. Spokane, WA 99215

CXT
Precast Products

901 N. Highway 77 Hilders, TX 75645

ROCKY MTN LEFT HAND
BUILDING NUMBER RM-408

NOTICE
The information contained herein is proprietary and the exclusive property of CXT Incorporated. The information may only be used by the original recipient for the purpose intended. Reproduction or distribution of this information is strictly prohibited without the prior written consent of CXT Incorporated. By accepting use of this information, CXT Incorporated grants no warranty, express or implied, including a warranty of merchantability or of fitness for a particular purpose.

REV.	DESCRIPTION	DATE	BY	CHKD BY

INTERIOR ELEVATIONS

DWG. NO.	SHEET	REV.
RM-03	3	1B

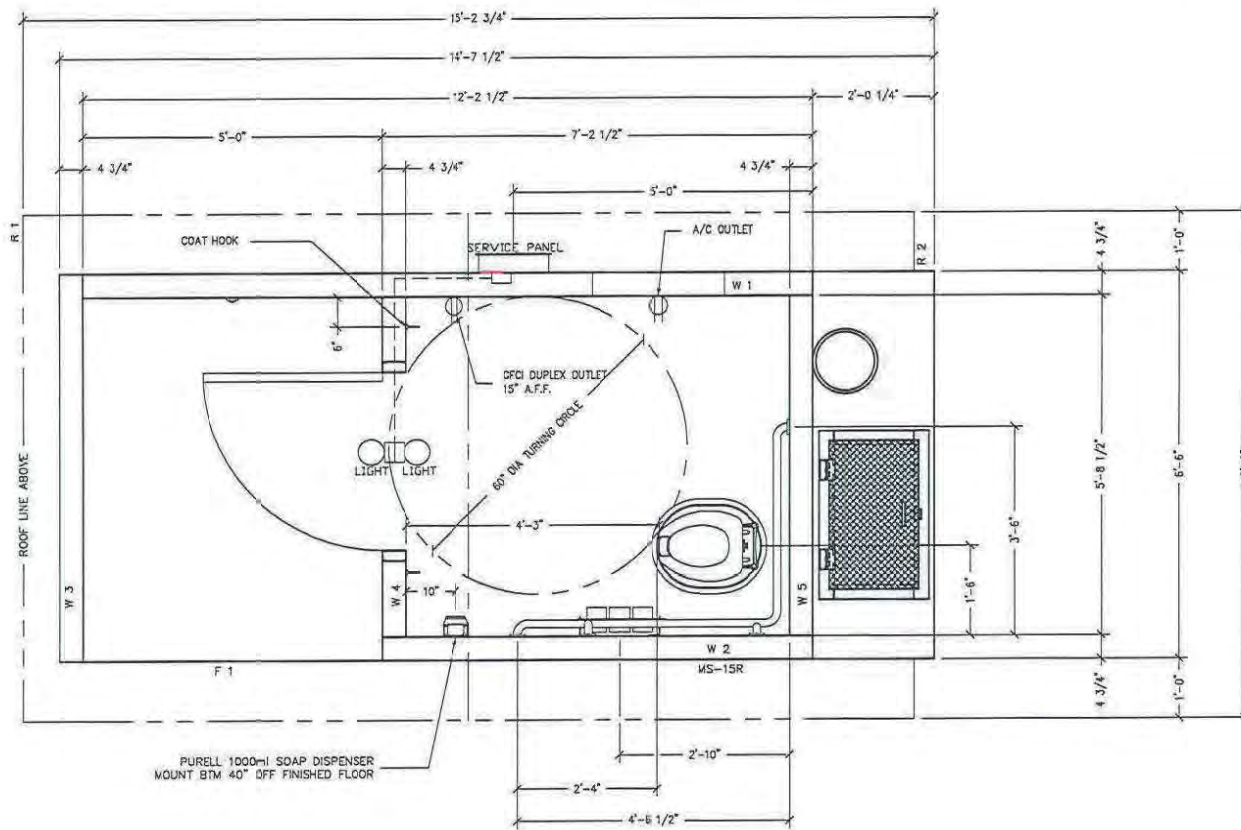

**CXT INCORPORATED
CONTROLLED COPY**
IF YOU RECEIVE THIS COPY
IT IS NOT TO BE REPRODUCED
OR COPIED FOR ANY OTHER PROJECT
WITHOUT THE WRITTEN APPROVAL OF CXT

3626 N. Siltman Bldg. #7 Spokane, WA 99216



801 N. Highway 77 (Hilborn, TX 75645)

**ROCKY MTN LEFT HAND
BUILDING NUMBER RM-409**

NOTICE
The information contained herein is proprietary and the exclusive property of CXT Incorporated. The information may only be used by the original recipient for the purpose intended. Reproduction or distribution of this information is strictly prohibited without the prior written consent of CXT Incorporated. In drawing use of this information, CXT Incorporated grants no warranty, express or implied, including a warranty of merchantability or of fitness for a particular purpose.

CXT Incorporated

REV.	DESCRIPTION	DATE	BY

FLOOR PLAN

DWG NO. **RM-04** SHEET **4** REV. **1.6**

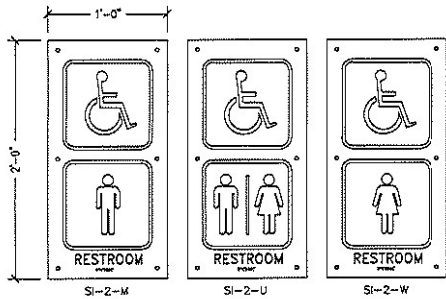

SIGN SI-2 DETAIL

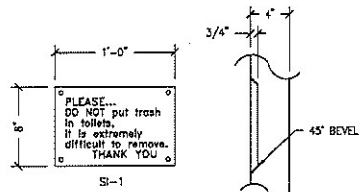

SIGN SI-1 DETAIL

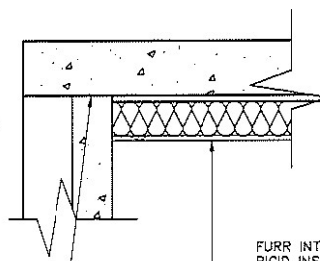

FURRING DETAIL

FURR INTERIOR CEILING W/ 2x4 STUDS,
RIGID INSULATION
(MINIMUM WALL SYSTEM INSULATION RATING OF R-19)
W/ 1/8" FIBERGLASS REINFORCED PANEL
ON 1/2" PLYWD & VAPOR BARRIER
CAULK ALL INTERIOR SEAMS.

SEAL ALL JOINTS OF
OUTSIDE PANELS W/
EXTERIOR GRADE SEALANT

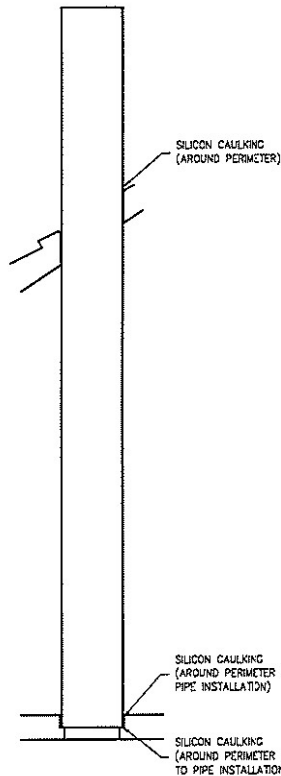

VENT PIPE DETAIL

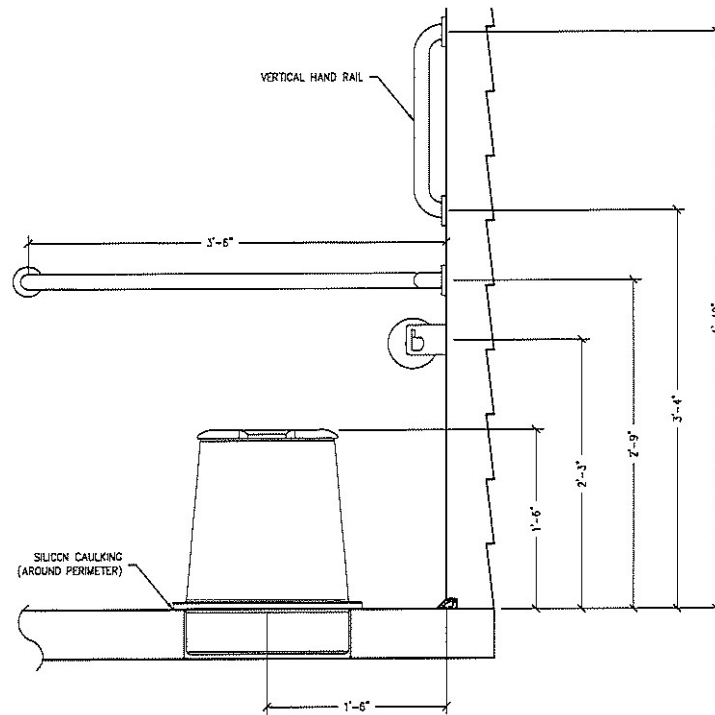

RISER CAULKING DETAIL

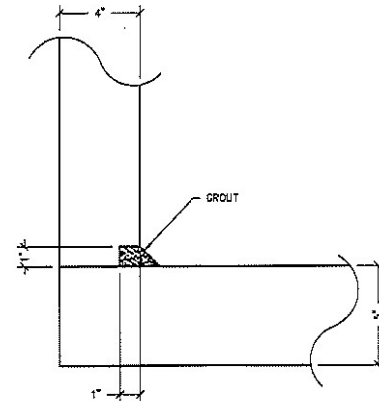

WALL JOINT DETAIL

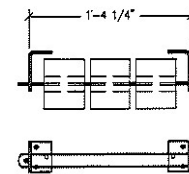

DISPENSER DETAIL

3206 N. Sullivan Blvd. #7 Spokane, WA 99216



801 N. Highway 77 HEBERS, TX 78845

PROJECT: ROCKY MTN LEFT HAND BUILDING NUMBER RM-405

NOTICE: The information contained herein is proprietary and the exclusive property of CXT Incorporated. The information may only be used by the original recipient for the purpose intended. Reproduction or distribution of this information is strictly prohibited without the prior written consent of CXT Incorporated. For general use of this information, CXT Incorporated grants all necessary, express or implied, including a warranty of non-infringement or of fitness for a particular purpose.

CXT Incorporated			
DATE	BY	CHKD	APP'D

FINISH DETAILS

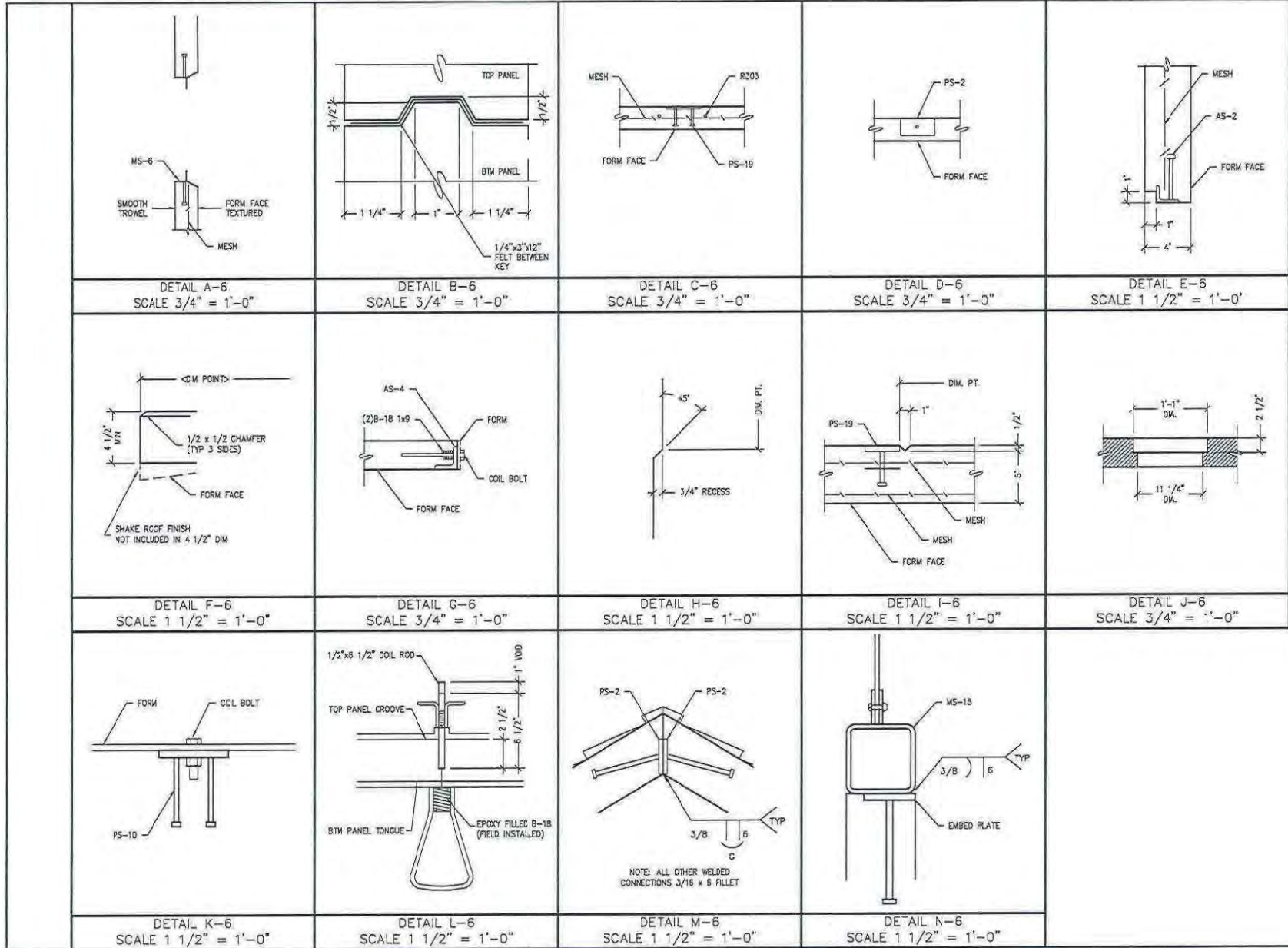

CXT INCORPORATED
CONTROLLED COPY
It is the responsibility of the user to ensure that this document is the correct and current version.

3000 N. Seltman Blvd., Ft. Spokane, WA 99216



Precast Products
801 N. Highway 77 Willabro, TX 76845

ROCKY MTN LEFT HAND
BUILDING NUMBER RM-409

NOTICE
The information contained herein is proprietary and the exclusive property of CXT Incorporated. The information may only be used by the original recipient for the purpose intended. Reproduction or distribution of this information in any form without the prior written consent of CXT Incorporated. By allowing use of this information, CXT Incorporated grants no warranty, express or implied, including a warranty of merchantability or of fitness for a particular purpose.

CXT Incorporated

REV.	DESCRIPTION	DATE

CASTING DETAILS

PRO. NO.	SHEET	REV.
RM-06	6	1B

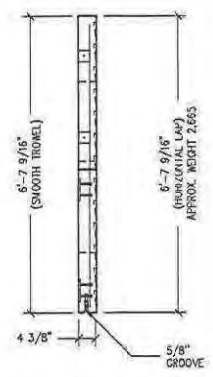
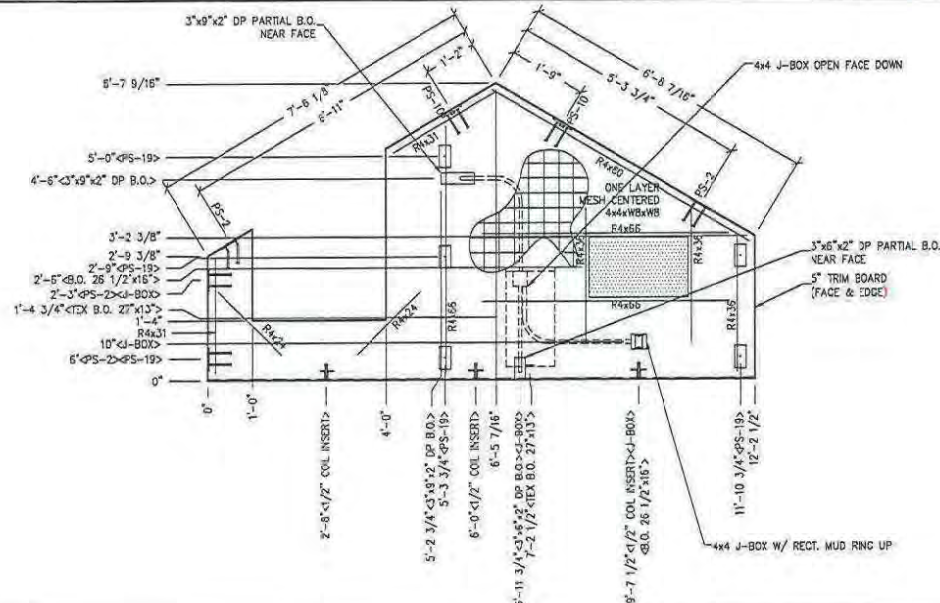

- NOTE:
1. REINFORCING BARS R4x24 TO BE PLACED IN PAIRS, ONE AT EACH FACE OF PANEL WITH 3/4" COVER.
 2. REBAR CLEAR COVERAGE DEPTH: FORM FACE: 3/4" CLEAR COVERAGE
 3. UNSPECIFIED: CENTERED

UPPER PANEL

STANDARD MATERIALS	
ITEM	QTY
AS-2	3
PS-2	6
PS-10	2
PS-19	9
B-18	3
R4x80	1
R4x66	3
R4x44	3
R4x36	3
R4x31	2
R4x24	4
R4x143	1
R4x94	1
1/2" COIL INSERT	3
4x4 J-BOX	3
RECT MUD RING	2
3'x6'x2" DP B.O.	2
3'x6'x2" DP B.O.	1
TEX B.O. 27'x13'	1
E.O. 26 1/2'x16"	1

CU. FT. CONC.	35.3 (1.31)	SQ. FT. W.A.F.	98
APPROXIMATE WEIGHT		5,295	

CXT INCORPORATED
 CONTROLLED COPY
 2505 N. SILVER BLDG. #7 SPOKANE, WA 99218

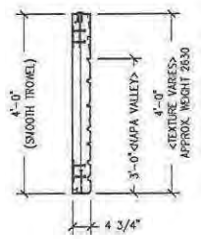
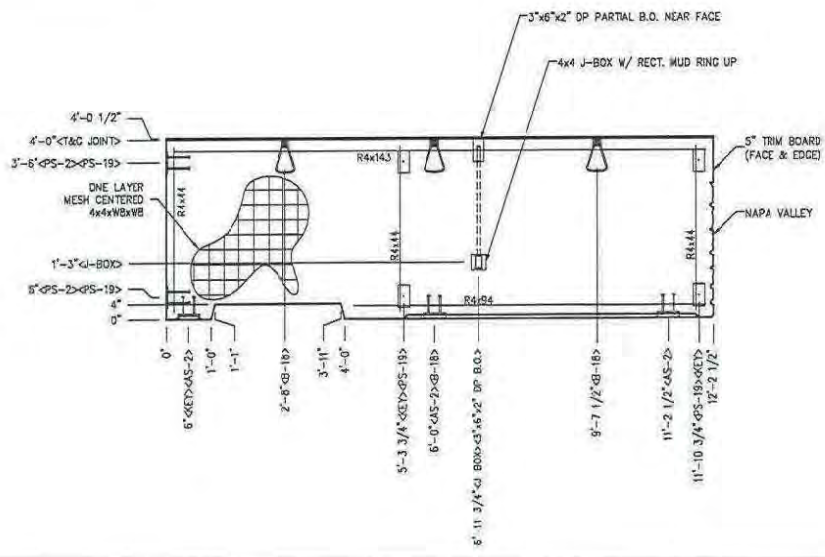

- NOTE:
1. REINFORCING BARS R4x24 TO BE PLACED IN PAIRS, ONE AT EACH FACE OF PANEL WITH 3/4" COVER.
 2. REBAR CLEAR COVERAGE DEPTH: FORM FACE: 3/4" CLEAR COVERAGE
 3. UNSPECIFIED: CENTERED
 4. RECESS B-18 INSERTS 1/2"

BOTTOM PANEL

2505 N. SILVER BLDG. #7 SPOKANE, WA 99218
CXT
Precast Products
 901 N. HIGHWAY 77 HILBURN, TX 76045

ROCKY MTN LEFT HAND
 BUILDING NUMBER RM-409

NOTICE
 The information contained herein is proprietary and the exclusive property of CXT Incorporated. The information may only be used by the original recipient for the purpose intended. Reproduction or distribution of this information is strictly prohibited without the prior written consent of CXT Incorporated. By accepting use of this information, CXT Incorporated grants no warranty, express or implied, including a warranty of merchantability or of fitness for a particular purpose.

REV.	DATE	BY	CHKD.	APP'D.	NOTED

WALL PANEL	
MARK W1	
DWG. NO.	RM-07
SHEET	7
REV.	18

UPPER PANEL

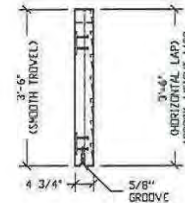
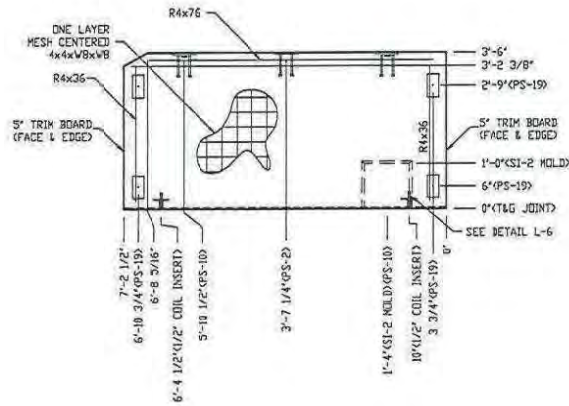

NOTE:
1. REBAR TO BE CENTERED.

EXCLUDED MATERIALS		
ITEM	QTY	
AS-2	2	
PS-2	1	
PS-19	8	
PS-10	2	
B-18	2	
R4x76	1	
R4x44	2	
R4x36	2	
R4x56	2	
1/2" COIL INSERT	2	
MS-2	1	

CU. FT. CONC.	21.3 (0.79)	SQ. FT. W.K.F.	54
APPROXIMATE HEIGHT			
3.195			

CXT INCORPORATED CONTROLLED COPY
THIS INFORMATION IS PROPRIETARY AND NOT TO BE REPRODUCED OR TRANSMITTED IN ANY FORM OR BY ANY MEANS, ELECTRONIC OR MECHANICAL, INCLUDING PHOTOCOPYING, RECORDING, OR BY ANY INFORMATION STORAGE AND RETRIEVAL SYSTEM.

BOTTOM PANEL

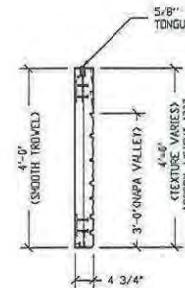
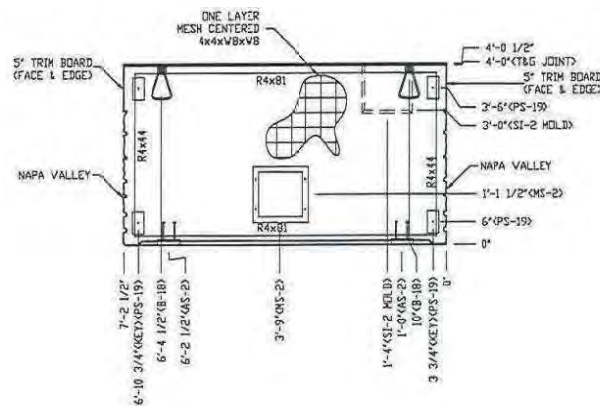

NOTE:
1. REBAR TO BE CENTERED.
2. RECESS 3-18 INSERT 1/2"

3820 N. Sullivan Blvd, #7 Spokane, WA 99216
CXT
Precast Products
 901 N. Highway 77 Hillsboro, TX 75645
ROCKY MTN LEFT HAND
 BUILDING NUMBER RM-408

NOTE:
The information contained herein is proprietary and the exclusive property of CXT Incorporated. The information may only be used by the original recipient for the purpose intended. Reproduction or distribution of this information is strictly prohibited without the prior written consent of CXT Incorporated. By obtaining use of this information, CXT Incorporated grants no warranty, express or implied, including a warranty of merchantability or of fitness for a particular purpose.

REV.	DATE	BY	CHKD.	APP'D.

WALL PANEL
 MARK W2
 SHEET 8
 RM-08
 REV. 18

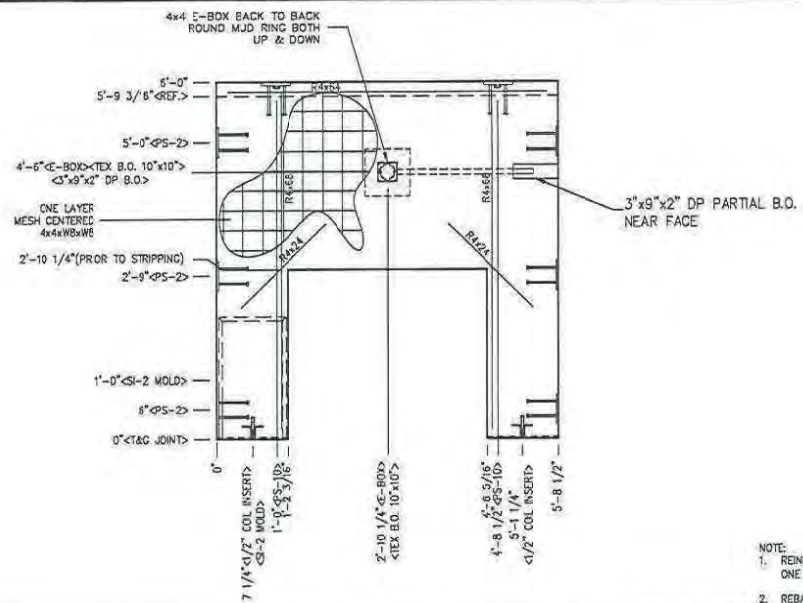
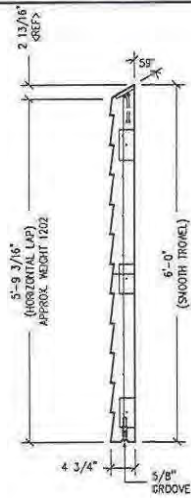

UPPER PANEL

EMBEDDED MATERIALS		
ITEM	QTY	
AS-2	2	
PS-2	10	
PS-10	2	
B-18	2	
R4x6E	4	
R4x4	1	
R4x24	2	
R4x10	2	
1/2\"/>		

CU. FT. CONC.	SQ. FT. W.A.F.
11.6 (0.43)	34

APPROXIMATE WEIGHT
1,743

**CXT INCORPORATED
CONTROLLED COPY**
IT IS THE POLICY OF CXT
AND ITS REPRESENTATIVE TO MAINTAIN THE INTEGRITY OF ALL INFORMATION

- NOTE:
1. REINFORCING BARS R4x6E TO BE PLACED IN PAIRS, ONE AT EACH FACE OF PANEL WITH 3/4\"/>

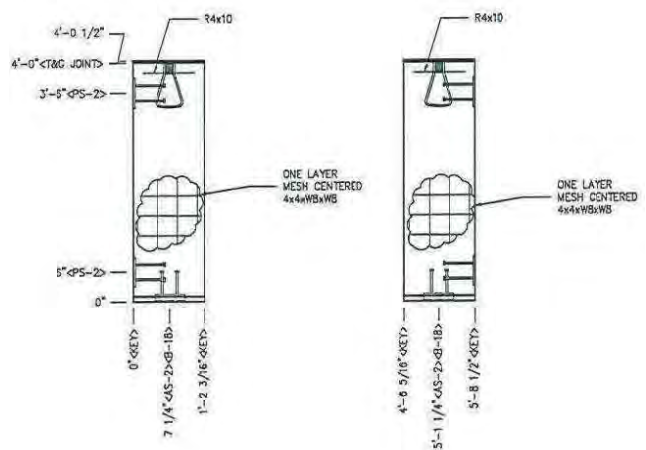
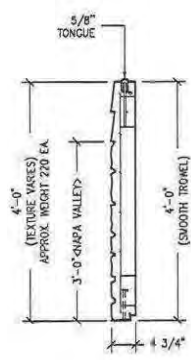

BOTTOM PANEL

- NOTE:
1. RECESS B-18 INSERTS 1/2\"/>

3206 N. Sullivan Blvd. #7 Spicewood, WA 99276

CXT
Precast Products

801 N. Highway 77 Hillborn, TX 78645

ROCKY MTN LEFT HAND
BUILDING NUMBER RM-408

NOTE:
The information contained herein is proprietary and the exclusive property of CXT Incorporated. Its information may only be used by the original recipient for the purpose intended. Reproduction or distribution of this information is strictly prohibited without the prior written consent of CXT Incorporated. In obtaining use of this information, CXT Incorporated grants no warranty, express or implied, including a warranty of merchantability or of fitness for a particular purpose.

CXT Incorporated

REV.	DESCRIPTION	DATE	BY	CHKD.

WALL PANEL
MARK W4

DWG. NO. **RM-10** SHEET **10** REV. **18**

UPPER PANEL

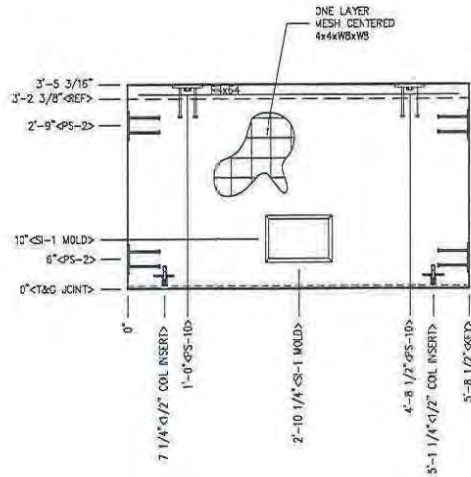
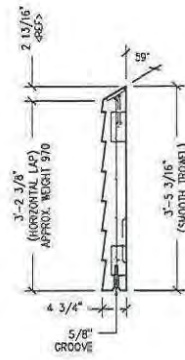

NOTE:
1. REBAR TO BE CENTERED.

EMBEDDED MATERIALS	
ITEM	QTY
AS-2	2
PS-2	8
PS-10	2
B-18	2
R4x64	3
1/2" COIL INSERT	2

CU. FT. CONC.	SQ. FT. W.A.F.
14.8 (0.55)	42
APPROXIMATE WEIGHT	
2,215	

**CXT INCORPORATED
CONTROLLED COPY**
IT IS THE POLICY OF CXT TO CONTROL THE DISTRIBUTION OF ALL INFORMATION TO THE PUBLIC. ANY REPRODUCTION OR DISSEMINATION OF THIS INFORMATION WITHOUT THE WRITTEN CONSENT OF CXT INCORPORATED IS STRICTLY PROHIBITED.

BOTTOM PANEL

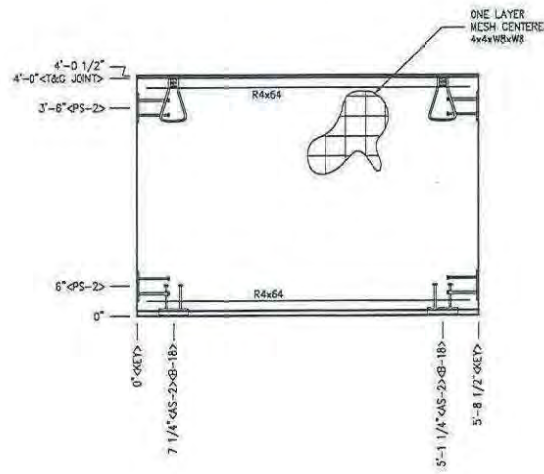
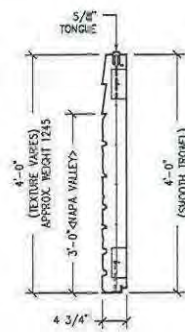

NOTE:
1. REBAR TO BE CENTERED.
2. RECESS B-18 INSERTS 1/2"

3205 N. Sullivan Blvd. #7 Spokane, WA 99216



ROCKY MTN LEFT HAND
BUILDING NUMBER RM-405

NOTE:
The information contained herein is proprietary and the exclusive property of CXT Incorporated. The information may only be used by the original recipient for the purpose indicated. Reproduction or distribution of this information is strictly prohibited without the prior written consent of CXT Incorporated. By obtaining use of this information, CXT Incorporated grants no warranty, express or implied, including a warranty of merchantability or of fitness for a particular purpose.

CXT Incorporated			
REV.	DESCRIPTION	DATE	BY

WALL PANEL		SHEET 11	
MARK WS		REV. 18	
QTY	RM-11		

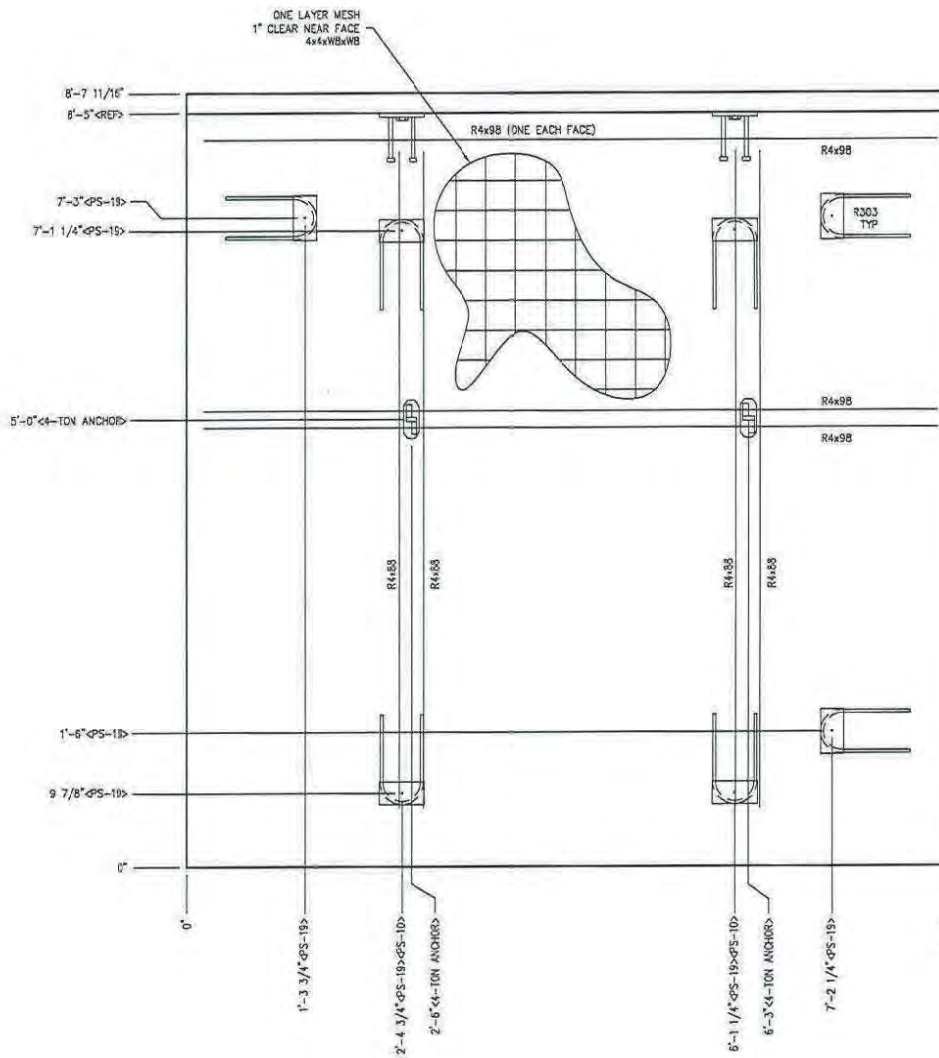
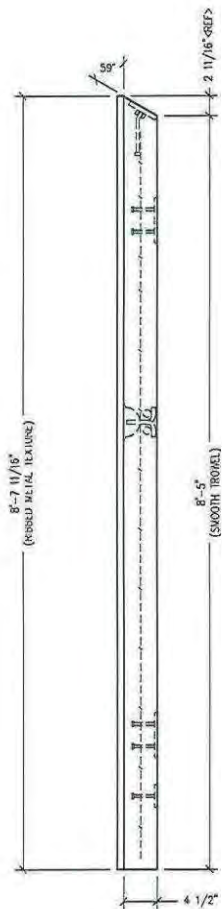

NOTE:
 1. REBAR CLEAR COVERAGE DEPTH:
 FORM FACE: 1-1/4"
 NEAR FACE: 3/4"

EMBEDDED MATERIALS	
ITEM	QTY
PS-19	2
PS-19	7
R303	7
FL-847	2
R4x98	4
R4x88	4

CU. FT. CONC.	28.1 (1.04)	SQ. FT. W.K.F.	72
APPROXIMATE WEIGHT		4,215	

CXT INCORPORATED CONTROLLED COPY
 IT IS THE POLICY OF CXT TO PROTECT THE INTEGRITY OF ITS INFORMATION AND TO PREVENT THE UNAUTHORIZED DISSEMINATION OF ITS INFORMATION TO ANY OTHER PARTY.

3808 N. Sullivan Blvd, #7 Spokane, WA 99215

CXT
Precast Products
 901 N. Highway 77 Hillboro, TX 75545

ROCKY MTN LEFT HAND
 BUILDING NUMBER RM-409

NOTICE
 The information contained herein is proprietary and the exclusive property of CXT Incorporated. The information may only be used by the original recipient for the purpose intended. Reproduction or distribution of this information is strictly prohibited without the prior written consent of CXT Incorporated. By checking use of this information, CXT Incorporated grants no warranty, express or implied, including a warranty of merchantability or of fitness for a particular purpose.

CXT Incorporated			
REV.	DESCRIPTION	DATE	BY

ROOF SLAB
 MARK R1
 SHEET NO. RM-12
 SHEET 12 OF 18
 REV. 18

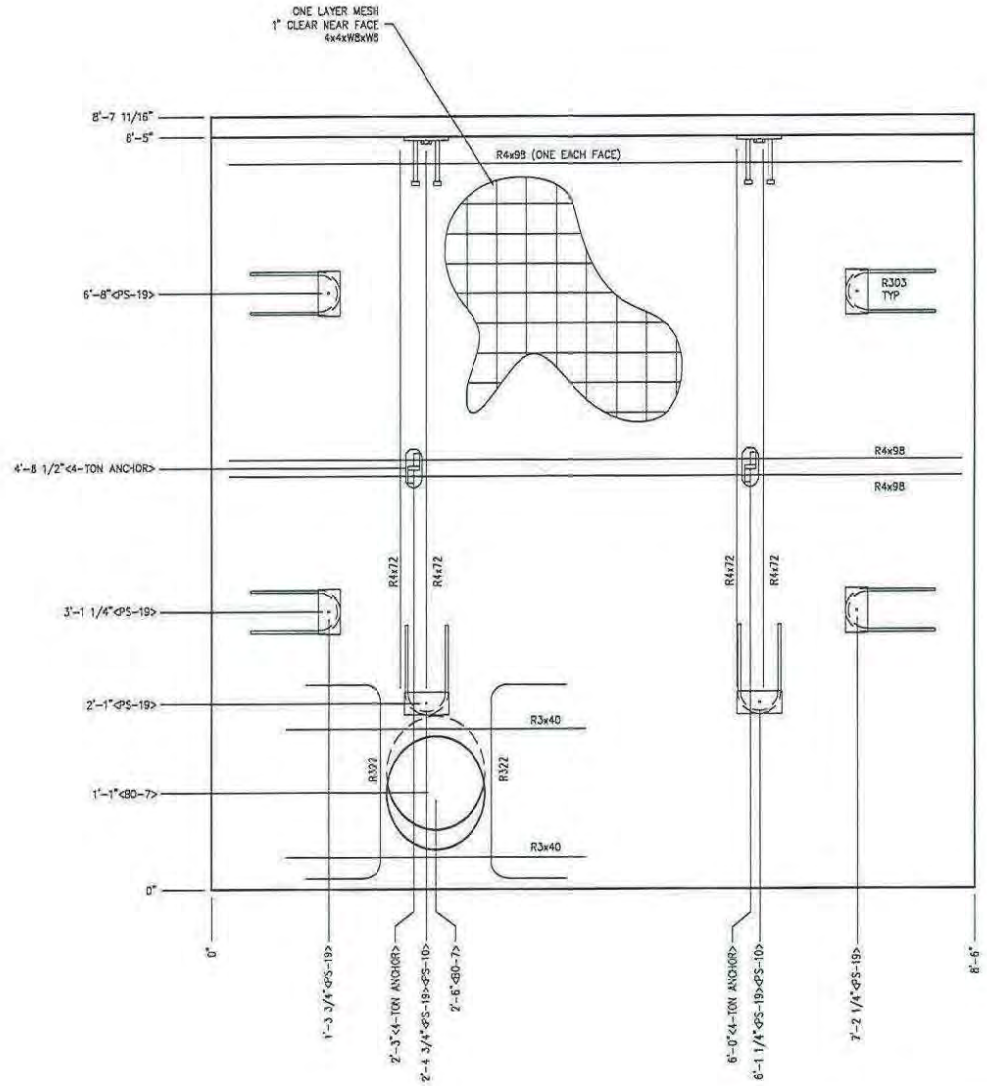
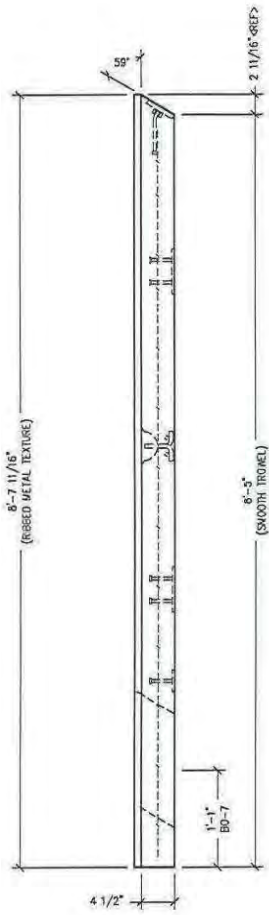

- NOTE:
- REBAR CLEAR COVERAGE DEPTH:
FORM FACE: 1-1/4"
NEAR FACE: 3/4"
 - R322 & R3x40 TO BE PLACED AT FORM FACE
 - ALL UNSPECIFIED REBAR IS TO BE CENTERED

EMBEDDED MATERIALS		
ITEM	QTY	REV
PS-10	2	
PS-19	6	
BO-7	1	
FL-B47	2	
R4x9B	4	
R4x72	4	
R3x40	2	
R322	2	
R303	6	

CU. FT. CONC.	27.7 (1.03)	SQ. FT. W.A.F.	72
APPROXIMATE WEIGHT			
4,155			

CXT INCORPORATED CONTROLLED COPY
 IT IS THE PROPERTY OF CXT INCORPORATED AND IS NOT TO BE REPRODUCED OR TRANSMITTED IN ANY FORM OR BY ANY MEANS, ELECTRONIC OR MECHANICAL, INCLUDING PHOTOCOPYING, RECORDING, OR BY ANY INFORMATION STORAGE AND RETRIEVAL SYSTEM.

3808 N. Sullivan Blvd, #7 Spokane, WA 99216

CXT
Precast Products
 901 N. Highway 77 Hillsboro, TX 75645

ROCKY MTN LEFT HAND
 BUILDING NUMBER RM-405

NOTICE:
 The information contained herein is proprietary and the exclusive property of CXT Incorporated. The information may only be used by the original recipient for the purpose intended. Reproduction or distribution of this information is strictly prohibited without the prior written consent of CXT Incorporated. By obtaining use of this information, CXT Incorporated grants no warranty, express or implied, including a warranty of merchantability or of fitness for a particular purpose.

CXT Incorporated			
REV.	DATE	BY	CHKD BY

REV.	DATE	BY	CHKD BY

ROOF SLAB		REV.
MARK R2		13
SHW NO.	RM-13	18

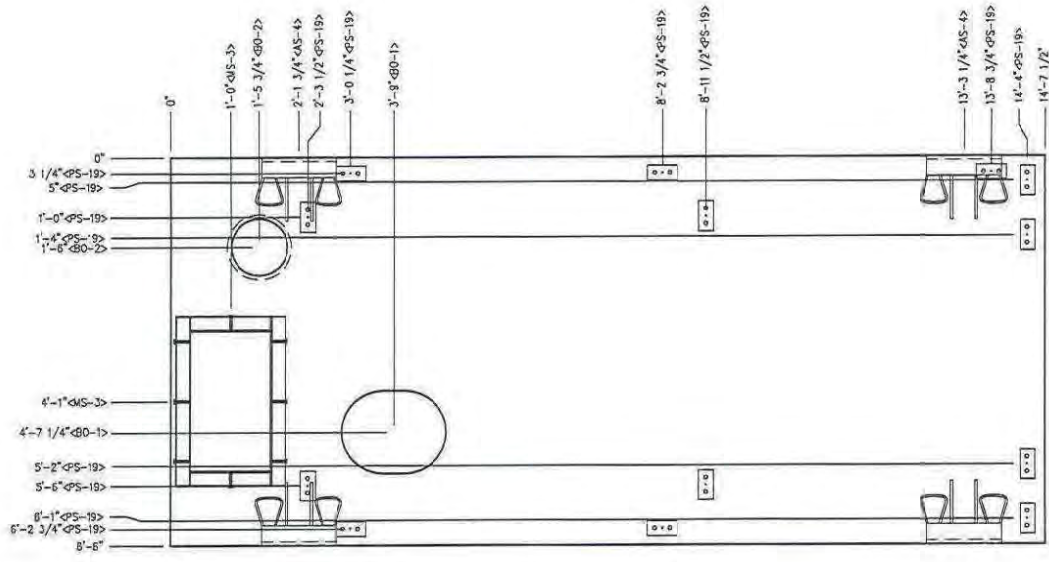

CXT INCORPORATED
CONTROLLED COPY
IT IS THE PROPERTY OF CXT INCORPORATED
AND IS NOT TO BE REPRODUCED OR COPIED
WITHOUT THE WRITTEN PERMISSION OF CXT INCORPORATED

3826 N. Sullivan Blvd, #7 Spokane, WA 99216



Precast Products

801 N. Highway 77 Midland, TX 79645

**ROCKY Mtn LEFT HAND
BUILDING NUMBER RM-409**

NOTES
The information contained herein is proprietary and the exclusive property of CXT Incorporated. The information may only be used by the original recipient for the purpose intended. Reproduction or distribution of this information is strictly prohibited without the prior written consent of CXT Incorporated. By giving use of this information, CXT Incorporated grants no warranty, express or implied, including a warranty of merchantability or of fitness for a particular purpose.

CXT Incorporated					
REV.	DESCRIPTION	DATE	BY	CHKD.	APP'D.

**FLOOR SLAB DIMENSIONS
MARK F1**

DWG NO.		SHEET		REV.	
RM-14		14			
		18			

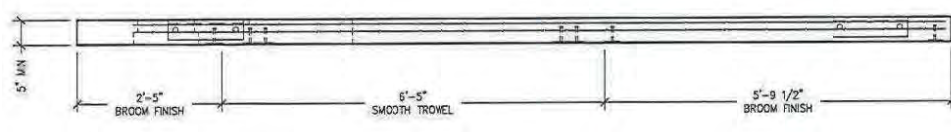
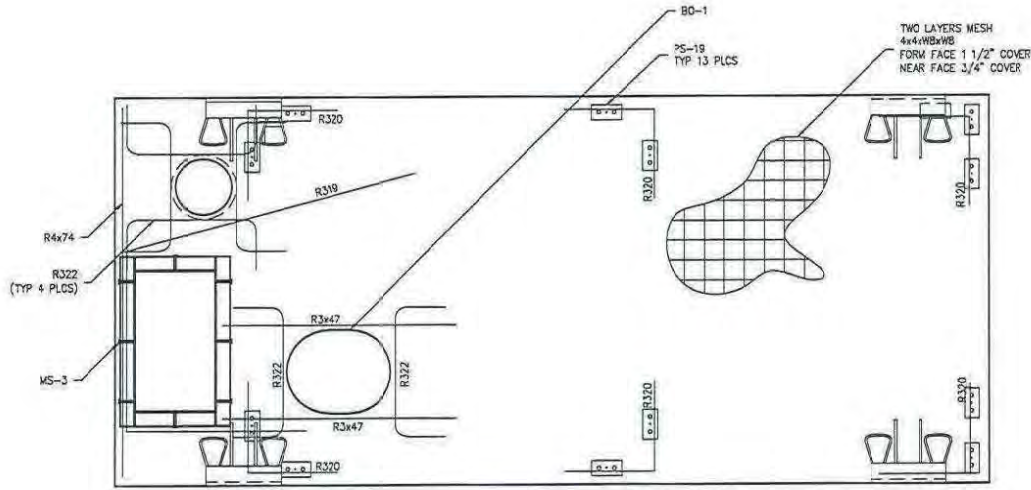

- NOTE
1. R4x74 & R319 REINFORCING BARS TO BE PLACED IN PAIRS, ONE AT EACH FACE OF SLAB.
 2. REBAR CLEAR COVERAGE DEPTH:
FORM FACE: 1 1/4"
NEAR FACE: 5/8"
 3. UNSPECIFIED OR NOT IN PAIRS: CENTERED.

EMBEDDED MATERIALS		
ITEM	QTY	
AS-4	4	
PS-19	13	
B-16	8	
R4x74	2	
R322	6	
R3x47	2	
R319	2	
R320	6	
MS-3	1	
BO-2	1	
BO-1	1	

CU. FT. CONC.	SG. FT. W.W.F.
37.2 (1.38)	190

APPROXIMATE WEIGHT
5,580

CXT INCORPORATED CONTROLLED COPY

3806 N. Sullivan Blvd, #7 Spokane, WA 99216



901 N. Highway 77 Hillboro, TX 75645

ROCKY MTN LEFT HAND
BUILDING NUMBER RM-409

NOTICE
The information contained herein is proprietary and the exclusive property of CXT Incorporated. The information may only be used by the original recipient for the purpose intended. Reproduction or distribution of this information is strictly prohibited without the prior written consent of CXT Incorporated. By granting use of this information, CXT Incorporated grants no warranty, express or implied, including a warranty of merchantability or of fitness for a particular purpose.

REV.	DATE	BY	CHKD.	APP'D.	REV.

FLOOR SLAB REINFORCEMENTS
MARK F1

DWG. NO.	SHEET	REV.
RM-15	15	1B

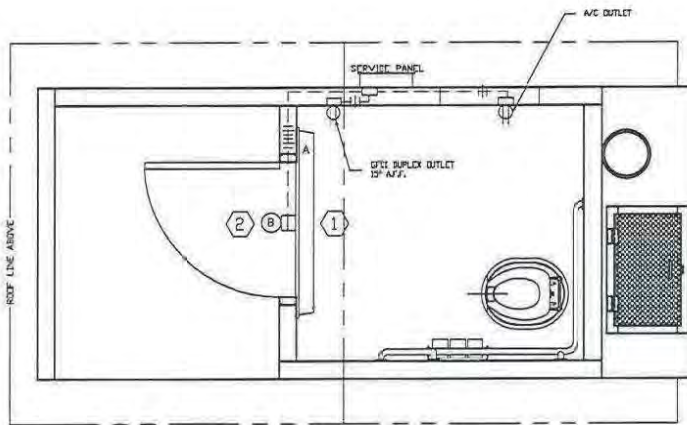

ELECTRICAL PLAN

N.T.S.

KEY NOTES

- ① OCCUPANCY SENSOR CONTROLLED LIGHT.
- ② LIGHT FIXTURE TO BE CONTROLLED BY PHOTOCELL.

GENERAL NOTES

1. RECESSED JUNCTION BOXES FOR SINGLE DEVICES SHALL HAVE SINGLE GANG MUD RINGS CAST IN CONCRETE WALLS.
2. ALL CONDUIT SHALL BE 3/4" MINIMUM. EXPOSED CONDUIT SHALL BE EMT, RECESSED SHALL BE PVC.
3. INSTALL ALL WIRING IN CONDUIT OR RELATED ENCLOSURES.
4. ALL ELECTRICAL INSTALLATIONS SHALL MEET THE 2008 VERSION OF THE NATIONAL ELECTRICAL CODE.
5. MINIMUM WIRE SIZE SHALL BE #12 AWG COPPER, THHN INSULATION UNLESS NOTED OTHERWISE.
6. ELECTRICAL DRAWINGS ARE DIAGRAMMATIC IN NATURE & MAY NOT SHOW EXACT LOCATIONS OF DEVICES. REFER TO WALL PANEL & OTHER DRAWINGS FOR EXACT LOCATIONS OF J-BOXES, ETC.

- SYMBOLS LEGEND**
- ① NOTE REFERENCE
 - Ⓟ PHOTOCELL
 - Ⓜ MOTION SENSOR
 - ▭ LOAD CENTER/PANEL-C
 - Ⓧ JUNCTION BOX
 - ▨ SURFACE MOUNTED CONDUIT
CROSSHATCH DENOTES WIRES,
(ALL #12AWG UND) ALWAYS
ONE WIRE TO BE GROUND WIRE
 - SURFACE MOUNTED CONDUIT
 - - - CONCEALED CONDUIT
 - Ⓢ WALL SWITCH

PANEL SCHEDULE

AMP 100 SURFACE MOUNT PANEL 120/240V, TP, 3W TOTAL CONNECTED VA LOAD 1,485 TOTAL CALCULATED VA LOAD 1,565

CIRCUIT					LOAD										
NO.	DESCRIPTION	DCP	TYPE	(VA)	(A)	PH	NO.	DESCRIPTION	DCP	TYPE	(VA)	(A)			
1	PHOTO CONTROLLED EXTERIOR LIGHT	1P/20A	C	37	0.3	A	2	RECEPTACLE MISC	1P/20A	R	1,250	7.2			
3	OFFICE RECEPTACLE	1P/20A	R	180	1.5	B	4	RESTROOM LIGHT	1P/20A	R	28	0.3			
5						A	B								
7						A	B								
9						A	B								
11						A	B								
13						A	B								
15						B	B								
17						A	B								
19						B	B								
					LOAD					CONNECTED			CALCULATED		
					(C)CONTINUOUS					37 X 1.25			47 VA		
					(R)REC (1ST 10KVA)					1,430 X 1.00			1,430 VA		
					(N)DN-CONTINUOUS					28 X 1.00			28 VA		
					(L)LARGEST MOTOR					0 X 1.25			0 VA		
					TOTAL LOAD					1,485 VA			1,565 VA		
													8.3 AMPS		

NOTE: MAXIMUM ALLOWABLE AIC IS 22K AMPS, PANEL MODIFICATIONS WILL BE REQUIRED (NOT BY CXT) IF TRANSFORMER CAPACITY EXCEEDS 175 KVA.

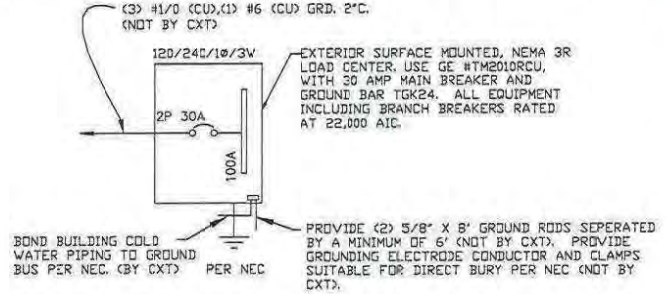

ONE-LINE POWER DIAGRAM

N.T.S.

LIGHTING FIXTURE SCHEDULE

FIXTURE NUMBER	VOLTAGE	WATTS	DESCRIPTION
A	120	28	LUMINAIRE VPF84 INTERIOR LIGHT FIXTURE, VPF8-4-28W HP-4000K-120-CP-WHT-WET-ECC-TX/SD SURFACE MOUNTED, LED LAMP 4 FT. WRAP AROUND LENS, LOW TEMPERATURE DRIVER, BUILT IN OCCUPANCY SENSOR ACTIVATED
B	120	37	RAB LIGHTING FIXTURE "SLIMFC37N-PC", EXTERIOR, WALL MOUNTED, ALUMINUM HOUSING 37 WATT LED LAMP, DARK SKY APPROVED, BRONZE FINISH, BUILT IN PHOTOELECTRIC CONTROL

NOTE: THE SOURCE OF EFFICACY OF EXTERIOR LIGHTING IS TO BE A MINIMUM OF 45 LUMENS PER WATT.

CXT INCORPORATED
CONTROLLED COPY
IF THIS DOCUMENT IS NOT PRINTED
FROM THE ORIGINAL PROJECT & FILE

3808 N. Sullivan Blvd, #7 Spokane, WA 99208

CXT
Precast Products

901 N. Highway 77 Hillsboro, TX 75645

PROJECT NO.
ROCKY MTN LEFT HAND
BUILDING NUMBER RM-409

NOTE
The information contained herein is proprietary and the exclusive property of CXT Incorporated. The information may not be used by the architect recipient for the purpose intended. Reproduction or distribution of this information is strictly prohibited without the prior written consent of CXT Incorporated. By sharing use of this information, CXT Incorporated grants no warranty, express or implied, including a warranty of merchantability or of fitness for a particular purpose.

CXT Incorporated

REV.	DESCRIPTION	DATE	BY	CHKD.

**ELECTRICAL PLAN
DETAILS & SCHEDULES**

DWG NO. **RM-17** SHEET **17** OF **18** REV. **18**

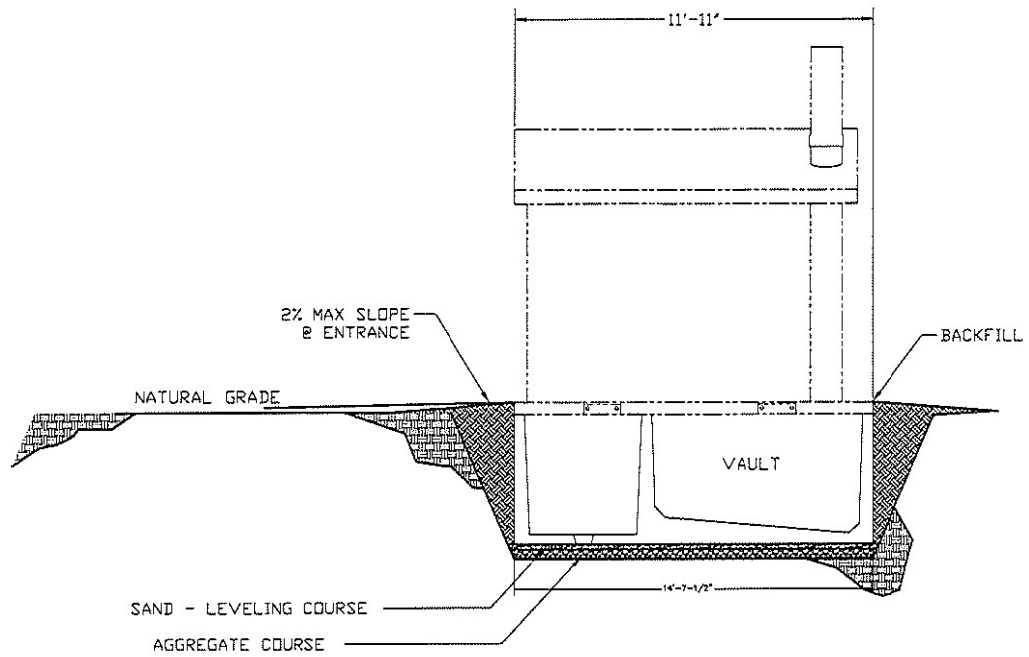

SIDE ELEVATION

3208 N. Sullivan Blvd, #7 Spokane, WA 99218



Precast Products

501 N. Highway 77 Milbourn, TX 75645

DOUBLE VAULT DETAIL
CXT STANDARD BUILDING

NOTICE
The information contained herein is proprietary and the exclusive property of CXT Incorporated. The information may only be used by the original recipient for the purpose intended. Reproduction or distribution of this information is strictly prohibited without the prior written consent of CXT Incorporated. In witness and of due information, CXT Incorporated grants no warranty, express or implied, including a warranty of merchantability or of fitness for a particular purpose.

CXT Incorporated			
NO.	DESCRIPTION	DATE	BY

SCALE: 1/4" = 1'-0" DATE: 02-02-70
 DRAWN: M.S. WARDEN, JR., INC.
 CHECKED: J.W. [signature]

VAULT INSTALLATION

DES. NO.		

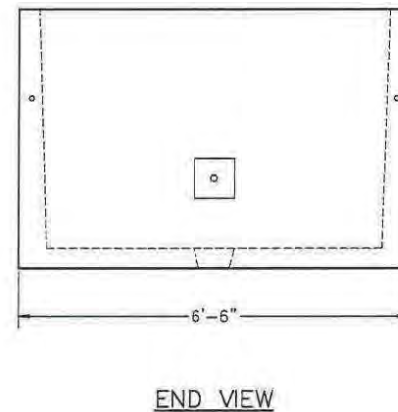
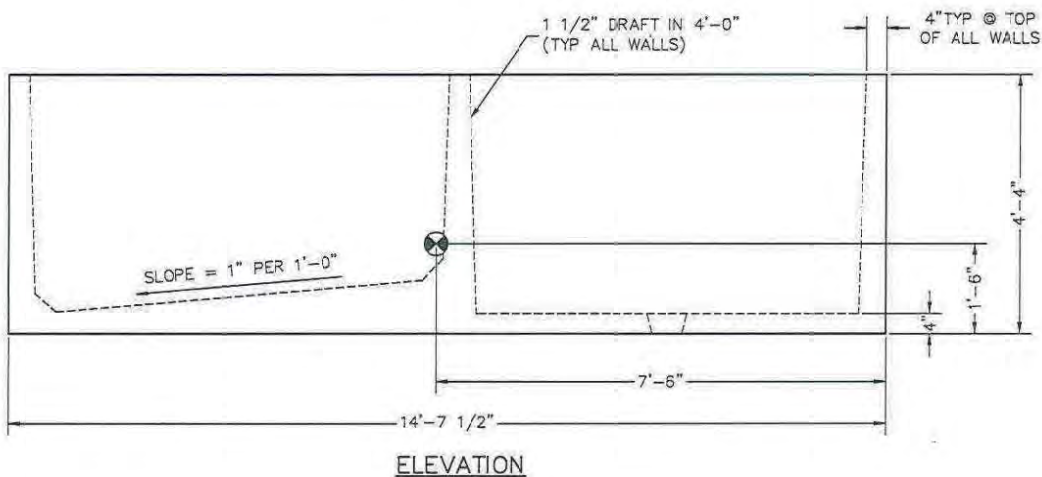
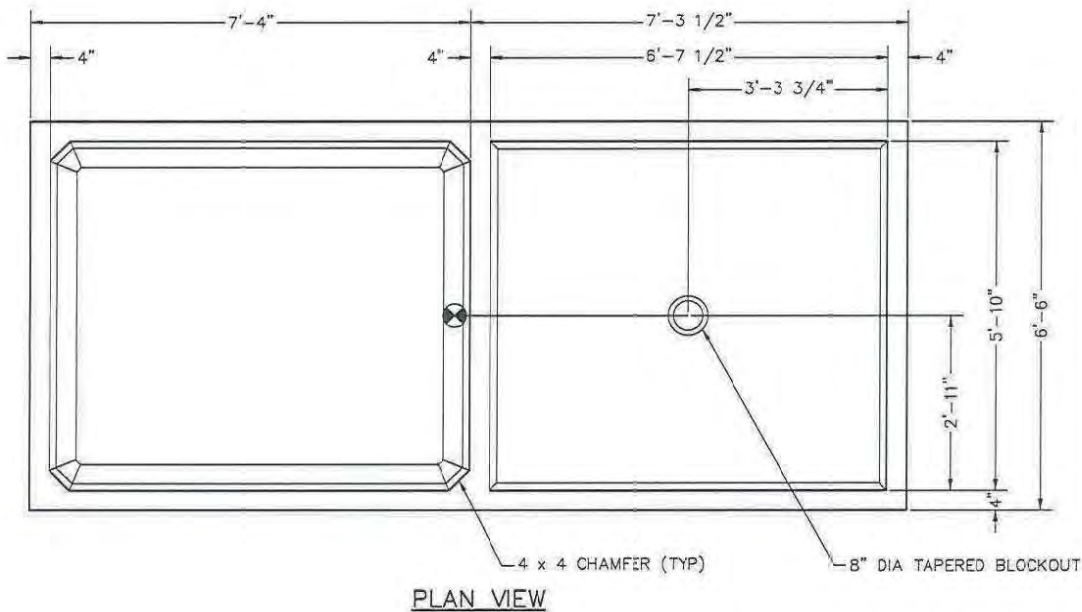

GENERAL NOTES

DESIGN CODE: 2009 IBC

LOADS:
 BACKFILL SURCHARGE: 200 PSF
 SOIL WEIGHT: 110 PCF
 ACTIVE SOIL PRESSURE COEF(Ka): 0.5

MATERIALS:
 CONCRETE: F'ci = 2500 PSI
 F'c = 5000 PSI

STEEL:
 REBAR=ASTM A615 GRADE 60
 WELDING NOT ALLOWED
 MIN LAP SPLICE IS 40 DIAMETERS
 ALL MESH IS 4x4xW8xW8
 MIN. MESH LAP IS TWO SQUARES
 MESH IS TO BE CENTERED IN PANEL
 B-18 SINGLE FLARED COIL LOOP BY
 DAYTON/RICHMOND INC. OR EQUAL

**CXT INCORPORATED
 CONTROLLED COPY**
 IT IS THE POLICY OF CXT
 TO BE SEEN BY ALL
 PROJECTS FOR PROTECTIVE PURPOSES

3808 N. Sullivan Blvd, #7 Spokane, WA 99216



Precast Products

901 N. Highway 77 Hallsboro, TX 75645

VAULT 2
 CXT STANDARD VAULT

NOTE
 The information contained herein is proprietary and the exclusive property of CXT Incorporated. The information may only be used by the original recipient for the purpose intended. Reproduction or distribution of this information is strictly prohibited without the prior written consent of CXT Incorporated. By showing use of this information, CXT Incorporated grants no warranty, express or implied, including a warranty of merchantability or of fitness for a particular purpose.

CXT Incorporated			
NO.	REVISION	DATE	BY

VAULT DIMENSIONS

DRG. NO.	SHEET	REV.
V2-1	1	A