

# EROSION, SEDIMENT & POLLUTION CONTROL PLAN

## FOR A TINY HOME LUXURY RESORT

### EROSION & SEDIMENT CONTROL NOTES:

- CONTRACTOR IS TO ADHERE TO THE TENNESSEE EROSION & SEDIMENT CONTROL HANDBOOK (AUGUST 2012).
- SEDIMENT AND EROSION CONTROL FACILITIES AND STORM DRAINAGE FACILITIES SHALL BE CONSTRUCTED PRIOR TO ANY OTHER CONSTRUCTION.
- ALL GRADED AREAS SHALL BE STABILIZED WITH A TEMPORARY FAST GROWING COVER AND/OR MULCH, NO LATER THAN 2 WEEKS AFTER EARTH DISTURBING ACTIVITY ENDS IN THOSE AREAS WHERE GRADING ACTIVITY HAS CEASED AND FINE GRADING WILL NOT TAKE PLACE FOR AT LEAST 30 DAYS.
- CONTRACTOR SHALL BE RESPONSIBLE DURING CONSTRUCTION FOR THE CONTINUOUS MAINTENANCE OF SEDIMENT AND EROSION CONTROL MEASURES AS CALLED FOR ON THE DRAWINGS AND PER NOTE 1 THIS SECTION.
- SEDIMENT AND EROSION CONTROL MEASURES SHALL BE LEFT IN PLACE UNTIL NOTICE OF TERMINATION IS OBTAINED FROM THE TENNESSEE DEPARTMENT OF ENVIRONMENT AND CONSERVATION (TDEC).
- ADDITIONAL EROSION CONTROL DEVICES SHALL BE USED AS A REQUIRED AND NOTED IN THE SWPPP.
- SILT FENCE SHALL BE CLEANED OR REPLACED WHEN SILT BUILDS UP TO WITHIN ONE-HALF OF SILT FENCE HEIGHT.
- MAXIMUM EMBANKMENT SLOPES TO BE AS FOLLOWS: CUT AREA-2:1; FILL AREA 3:1 (UNLESS OTHERWISE NOTED)
- EXISTING DRAINAGE STRUCTURES TO BE INSPECTED, REPAIRED AS NEEDED AND CLEANED OUT TO REMOVE ALL SILT AND DEBRIS.
- CONSTRUCTION EXIST SHALL CONSIST OF 6" THICK GRAVEL PAD OF 1-1/2" TO 3-1/2" DIAMETER STONE. 20' WIDE X 50' LONG. PAD TO BE MAINTAINED ON A CONTINUOUS BASIS.
- SEEDING AND FERTILIZING RATES OR TEMPORARY AND PERMANENT STANDS OF GRASS SHALL BE PER THE TENNESSEE EROSION & SEDIMENT HANDBOOK.
- IF FINES OR PENALTIES ARE LEVIED AGAINST THE PROPERTY OR PROPERTY OWNER BECAUSE OF LACK OF EROSION AND/OR SEDIMENT CONTROL, THE OWNER SHALL BE RESPONSIBLE FOR PAYMENT OF SUCH FINES OR PENALTIES OR THE COSTS OF ANY FINES OR PENALTIES SHALL BE DEDUCTED FROM THE CONTRACT AMOUNT.
- ALL SIDE DITCHES TO BE CLEANED AND/OR REPLACED TO PROVIDE PROPER DRAINAGE.
- STOCKPILED TOPSOIL IS TO BE SPREAD OVER LAWN AREAS AT COMPLETION OF CONTRACT AS REQUIRED BY CONTRACT.
- NEW FINISHED CONTOURS SHOWN ARE TOP OF PAVEMENT AND TOP OF TOPSOIL IN AREAS TO BE SEEDED.
- GRADING CONTRACTOR SHALL COOPERATE AND WORK WITH ALL OTHER CONTRACTORS PERFORMING WORK ON THIS PROJECT TO INSURE PROPER AND TIMELY COMPLETION OF THIS PROJECT.
- THE GRADING CONTRACTOR SHALL USE WHATEVER MEASURES ARE REQUIRED TO PREVENT SILT AND CONSTRUCTION DEBRIS FROM FLOWING ONTO ADJACENT PROPERTIES. THE CONTRACTOR SHALL COMPLY WITH ALL LOCAL EROSION, CONSERVATION, AND SILTATION ORDINANCES. THE CONTRACTOR SHALL REMOVE ALL TEMPORARY EROSION CONTROL STRUCTURES UPON COMPLETION OF PERMANENT DRAINAGE FACILITIES AND NOT BEFORE ALL AREAS DRAINING INTO THESE STRUCTURES ARE SUFFICIENTLY STABILIZED.
- THE GRADING CONTRACTOR SHALL TAKE ALL AVAILABLE PRECAUTIONS TO CONTROL DUST. THE CONTRACTOR SHALL CONTROL DUST BY SPRINKLING, OR BY OTHER METHODS AS DIRECTED BY THE ENGINEER AND OR OWNER'S REPRESENTATIVE AT NO ADDITIONAL COST TO OWNER.
- IT IS THE INTENT OF THIS PROJECT FOR THE CONTRACTOR TO VERIFY AND MATCH EXISTING CONDITIONS UNLESS OTHERWISE NOTED. THE CONTRACTOR SHALL NOTIFY THE ENGINEER/ARCHITECT OF ANY ITEMS THAT DO NOT EXIST AS SHOWN.
- THE CONTRACTOR SHALL REPAIR OR REPLACE IN-KIND ANY DAMAGE RELATED TO SEDIMENT AND EROSION CONTROL THAT OCCURS AS RESULT OF HIS WORK.

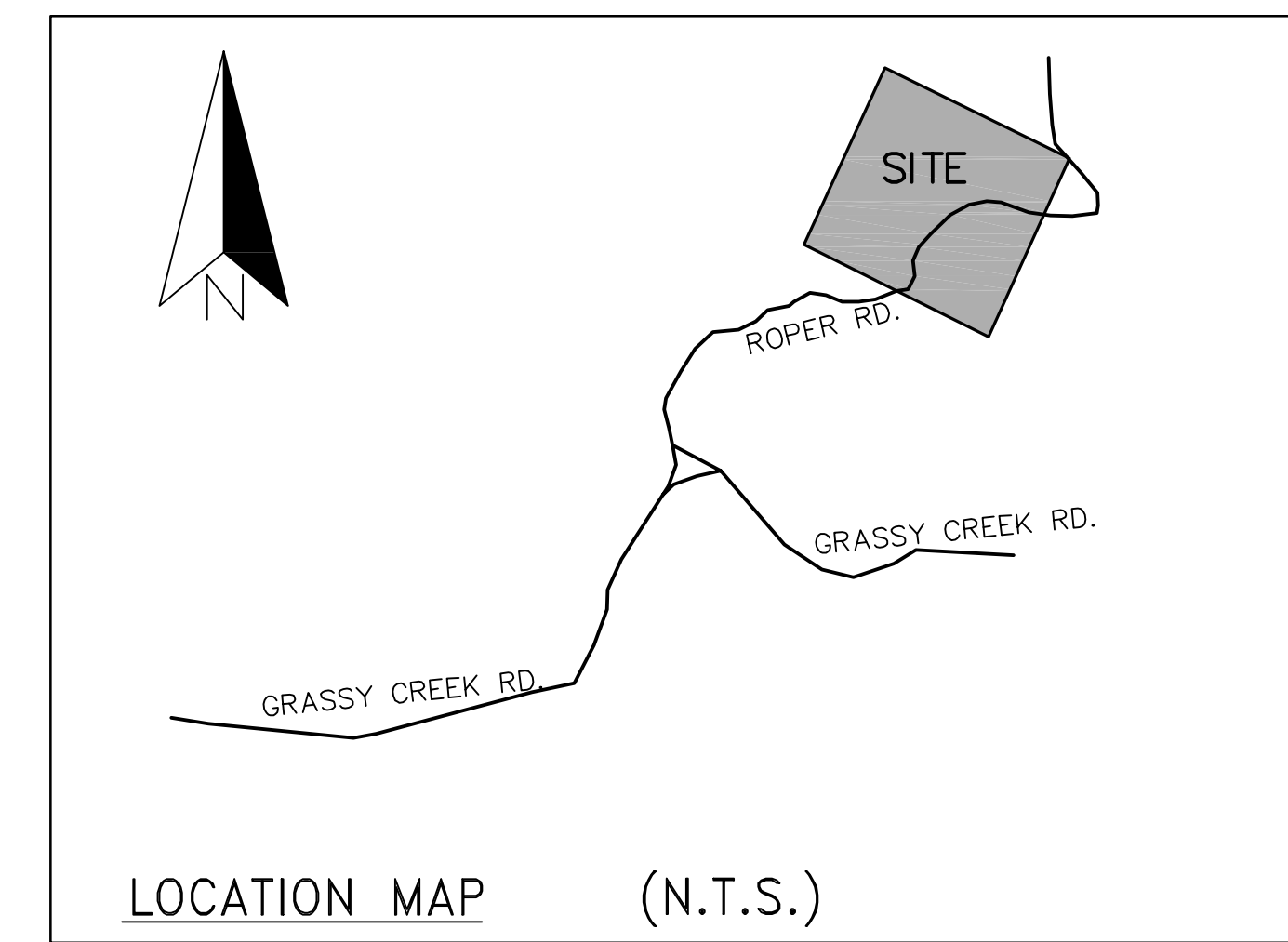

**SITE ADDRESS**  
177 ROPER ROAD  
COPPERHILL, TN 37317

**PARCEL NO.**  
125 013.00



### SHEET INDEX

- SHEET 1 OF 9 - COVER SHEET
- SHEET 2 OF 9 - DRAINAGE
- SHEET 3 OF 9 - DETAILS
- SHEET 4 OF 9 - INITIAL (CLEARING) PHASE
- SHEET 5 OF 9 - INITIAL (CLEARING) PHASE
- SHEET 6 OF 9 - INTERIM GRADING PHASE
- SHEET 7 OF 9 - INTERIM GRADING PHASE
- SHEET 8 OF 9 - FINAL PHASE
- SHEET 9 OF 9 - FINAL PHASE

### DESCRIPTION OF CONSTRUCTION ACTIVITIES

- CLEARING & REMOVAL OF TREES AND UNDERBRUSH
- MASS GRADING ACTIVITIES INCLUDING CUT/FILL SLOPES
- CONSTRUCTION OF GRAVEL ROADS INCLUDING DRAINAGE DITCHES AND PIPE CULVERTS
- INSTALLATION OF MULTIPLE SEPTIC SYSTEMS
- INSTALLATION OF A NEW WELL SYSTEM
- INSTALLATION OF UNDERGROUND UTILITIES
- CONSTRUCTION OF LEVEL PAD AREAS TO INCLUDE BLOCK WALLS
- INSTALLATION OF SLOPE STABILIZATION PRACTICES INCLUDING PERMANENT VEGETATION.

### TOTAL DISTURBED AREA

9.46 ACRES  
9.80 ACRES (+3.6%)

### PERMITTEE INFORMATION

**PRIMARY PERMITTEE**  
ROBER NIX  
177 ROPER ROAD DEVELOPMENT LLC (860) 803-2632

**SECONDARY PERMITTEE**  
ERIC WATERS (706) 455-5413

### SOIL DATA

ErC - EVARD-HAYESVILLE COMPLEX HYDROLOGIC SOIL GROUP B  
ErD - EVARD-HAYESVILLE COMPLEX HYDROLOGIC SOIL GROUP B  
GeD - GULLIED LAND-EVARD COMPLEX

### STORED CHEMICALS

DUE TO THE TINY HOMES BEING CONSTRUCTED OFF-SITE AND DELIVERED TO THE SITE THE ONLY POLLUTANTS/CHEMICALS THAT WILL BE STORED ON-SITE ARE ASSOCIATED WITH THE CONSTRUCTION OF THE BLOCK WALLS AND SEPTIC SYSTEMS.

- CONCRETE/MASONRY GROUT
- PVC PIPE SOLVENT AND CEMENT

\*FUEL FOR EQUIPMENT WILL NOT BE STORED ON-SITE

CONSTRUCTION SCHEDULE FOR 2023/2024							
MONTH	DEC	JAN	FEB	MAR	APR	MAY	JUN
INSTALLATION OF CONSTRUCTION EXIT, & PERIMETER SILT FENCE	█						
CONSTRUCT CONSTRUCTION ACCESS THROUGHOUT SITE	█						
CONSTRUCTION OF SEDIMENT TRAPS		█	█				
CLEARING & GRUBBING			█	█			
INTERMEDIATE GRADING, SEPTIC SYSTEM INSTALLATION, & ROAD CONSTRUCTION. INSTALL PIPE CULVERTS, OUTLET PROTECTION & STONE CHECK DAMS				█	█		
SLOPE STABILIZATION, TEMPORARY SEEDING, & PERMANENT SEEDING					█	█	
FINISHED PAD GRADING, BLOCK WALL CONSTRUCTION, AND INSTALL UTILITIES TO PADS						█	█
FINAL STABILIZATION							█
REMOVE TEMPORARY EROSION MEASURES							█

COVER SHEET  
EROSION, SEDIMENT & POLLUTION CONTROL PLAN  
FOR  
TINY HOME LUXURY RESORT  
177 ROPER ROAD  
COPPERHILL, TN

PJS 9-18-23  
DRAWN BY DATE  
PJS 9-18-23  
CHECKED BY DATE

**DPS DEVELOPMENT LLC**  
patrick@dpsdevelopment.com  
(760) 977-8007

REVISION	DATE
REVISED SITE PLAN & ES&PC MEASURES	12-11-23



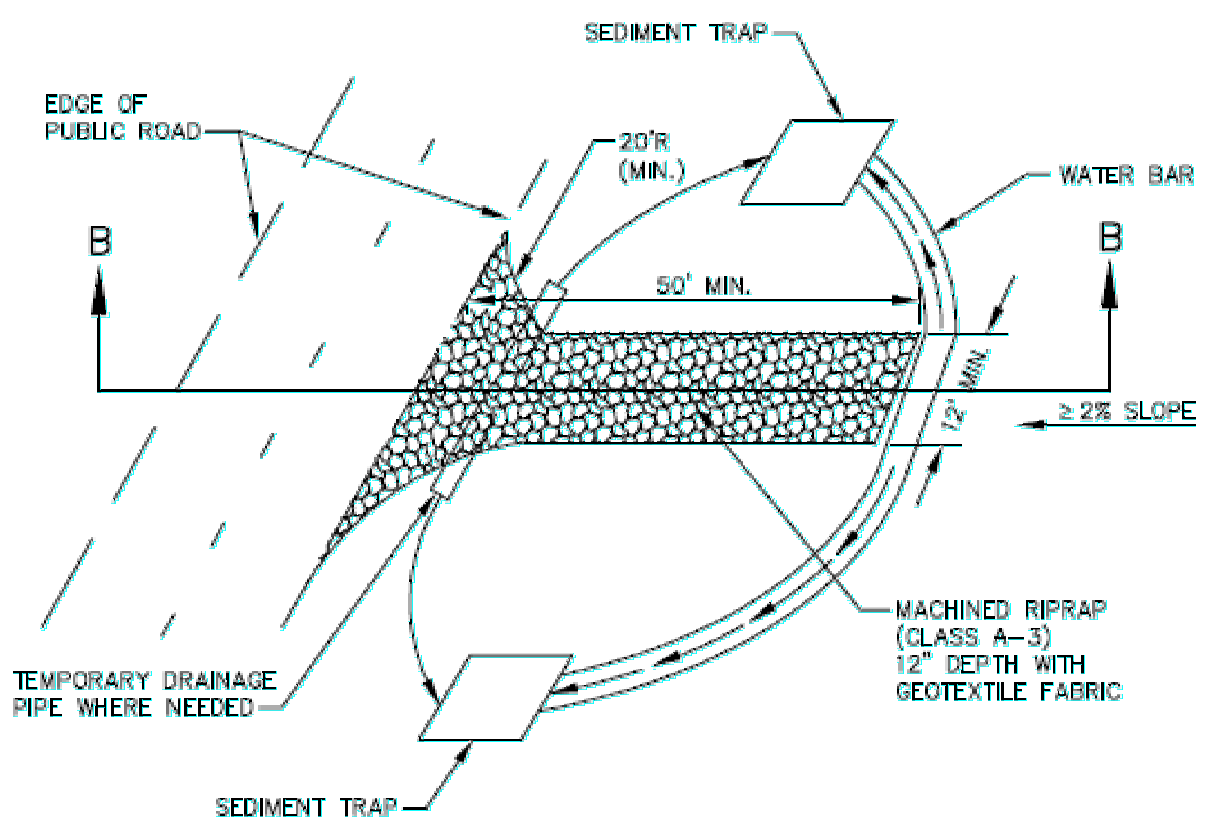

CE CONSTRUCTION EXIT DETAIL

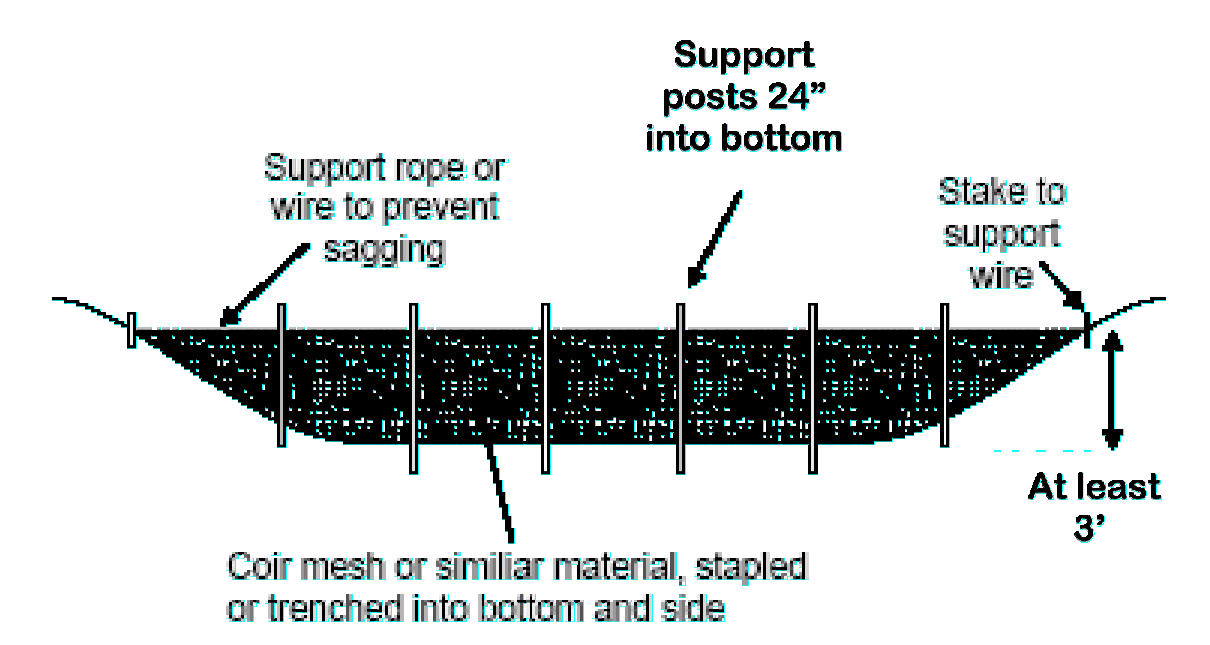

OP POROUS BAFFLE DETAIL

NOTE: POROUS BAFFLES TO BE PLACED IN SEDIMENT TRAP PERPENDICULAR TO FLOW

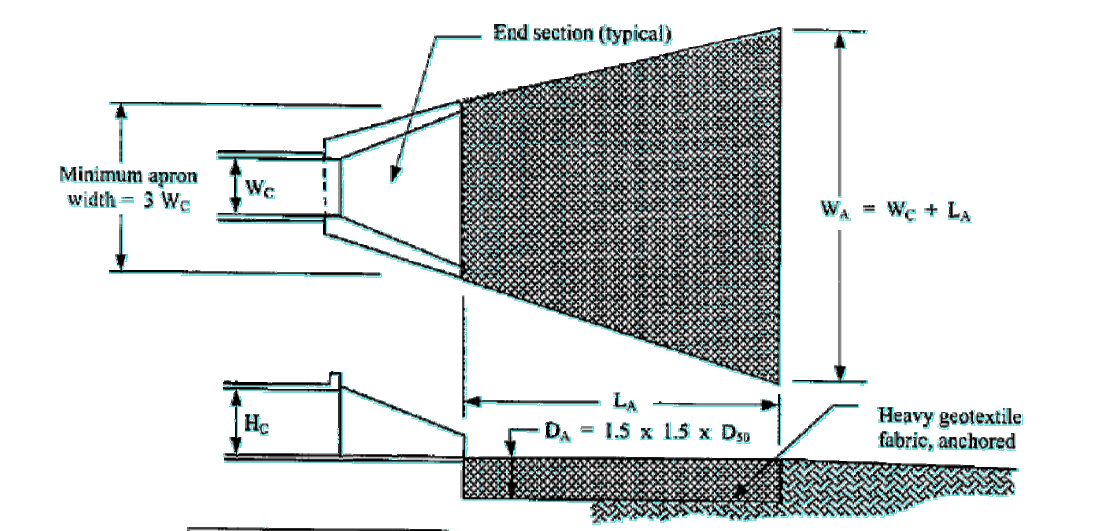

Tailwater < 0.5 Hc and Assuming Full Culvert Flow (Low Tailwater Conditions)

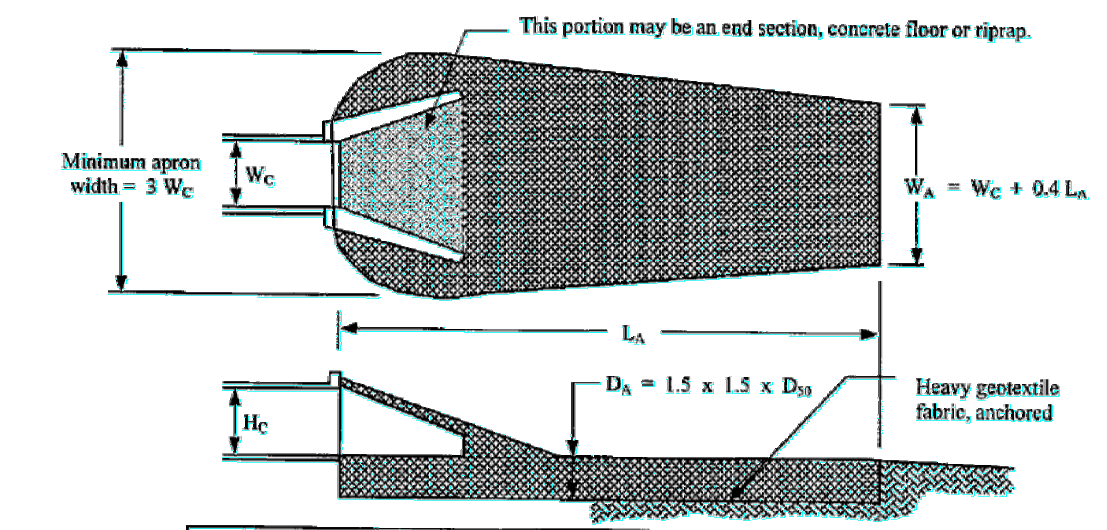

Tailwater > 0.5 Hc and Assuming Full Culvert Flow (High Tailwater Conditions)

NOT TO SCALE

**Riprap Aprons for Low Tailwater (downstream flow depth < 0.5 x pipe diameter)**

Culvert Diameter	Lowest value			Intermediate values to interpolate from												Highest value		
	Q	L <sub>a</sub>	D <sub>50</sub>	Q	L <sub>a</sub>	D <sub>50</sub>	Q	L <sub>a</sub>	D <sub>50</sub>	Q	L <sub>a</sub>	D <sub>50</sub>	Q	L <sub>a</sub>	D <sub>50</sub>			
12"	4	7	2.5	6	10	3.5	9	15	8	12	16	7	14	17	8.5			
15"	6.5	8	3	10	12	5	15	16	7	20	18	10	25	20	12			
18"	10	9	3.5	15	14	5.5	20	17	7	30	22	11	40	25	14			
21"	15	11	4	25	18	7	35	22	10	45	26	13	60	28	18			
24"	21	13	5	35	20	8.5	50	26	12	65	30	16	80	33	19			
27"	27	14	5.5	50	24	9.5	70	29	14	90	34	18	110	37	22			
30"	36	16	6	60	25	9.5	90	33	15.5	120	38	20	140	41	24			
36"	56	20	7	100	32	13	140	40	18	180	45	23	220	50	28			
42"	82	22	8.5	120	32	12	160	39	17	200	45	20	280	52	28			
48"	120	26	10	170	37	14	220	46	19	270	54	23	320	64	37			

OP OUTLET PROTECTION DETAIL

NOTE: SEE SHEET 2 FOR DIMENSIONS AND SPECIFICATIONS OF DRAINAGE OUTLETS

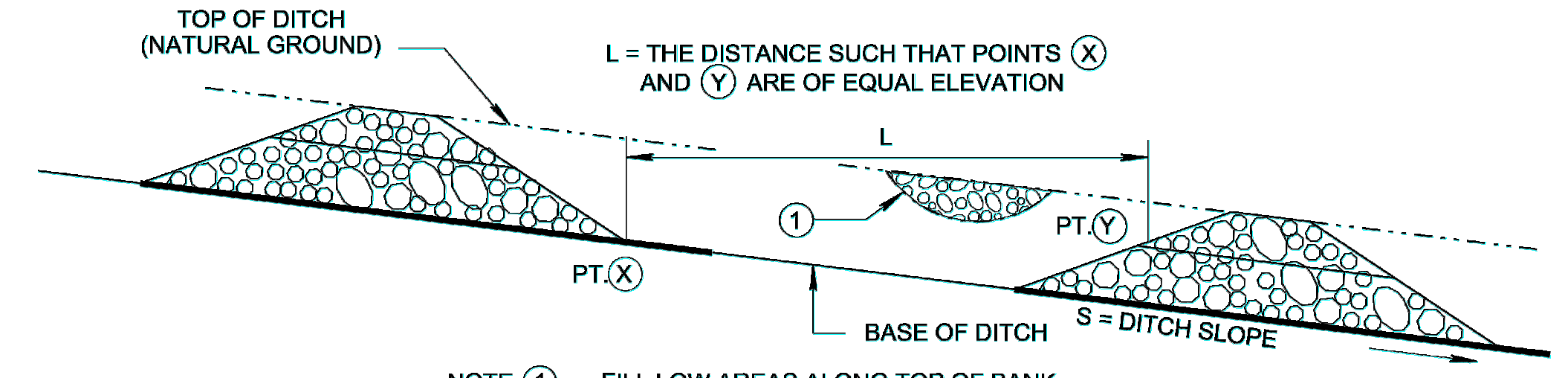

NOTE ①: FILL LOW AREAS ALONG TOP OF BANK TO PREVENT BACKWATER FROM EXISTING DITCH

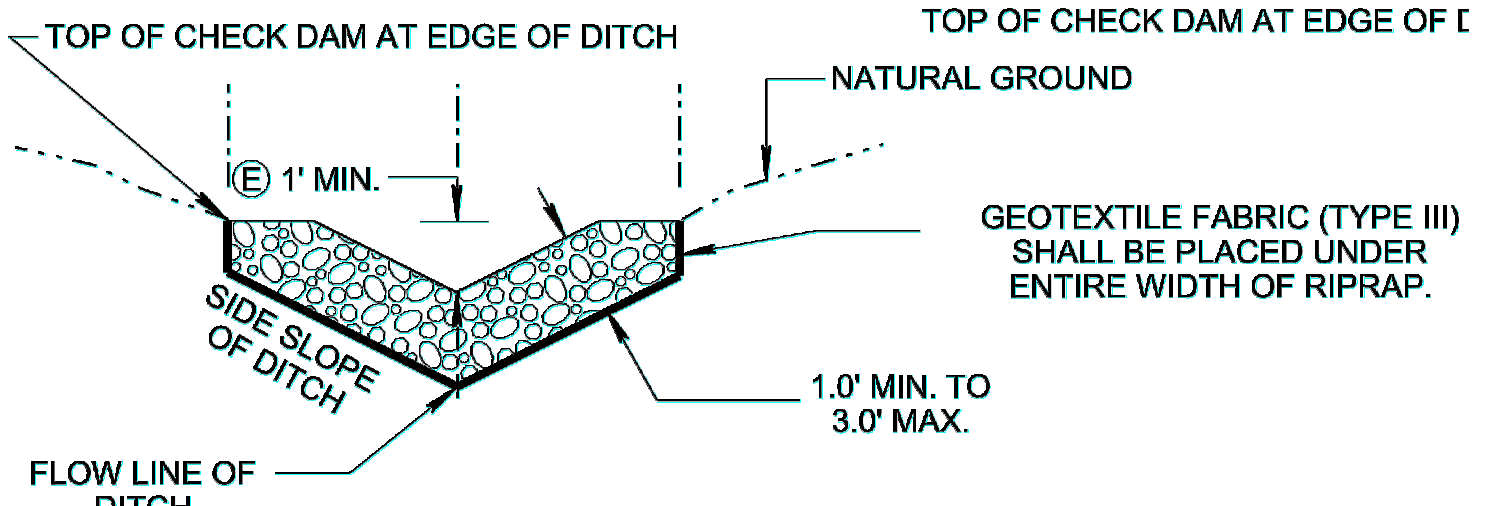

CD CHECK DAM DETAIL

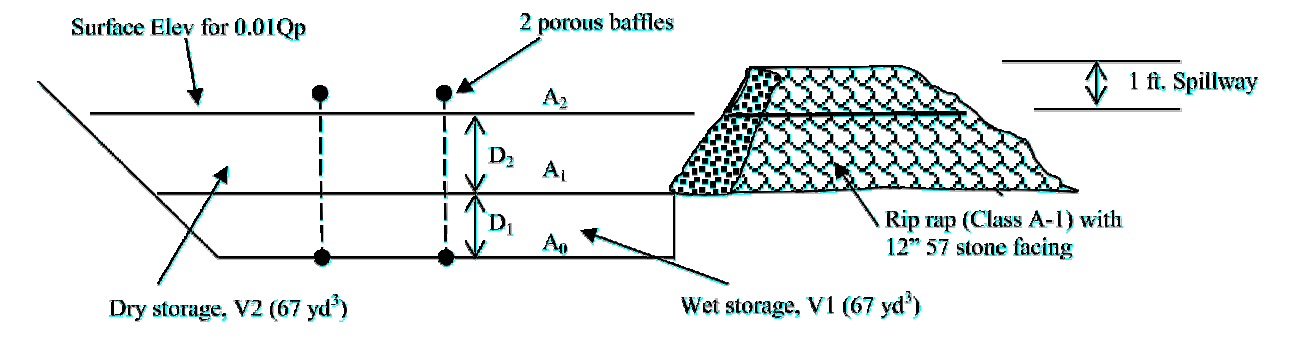
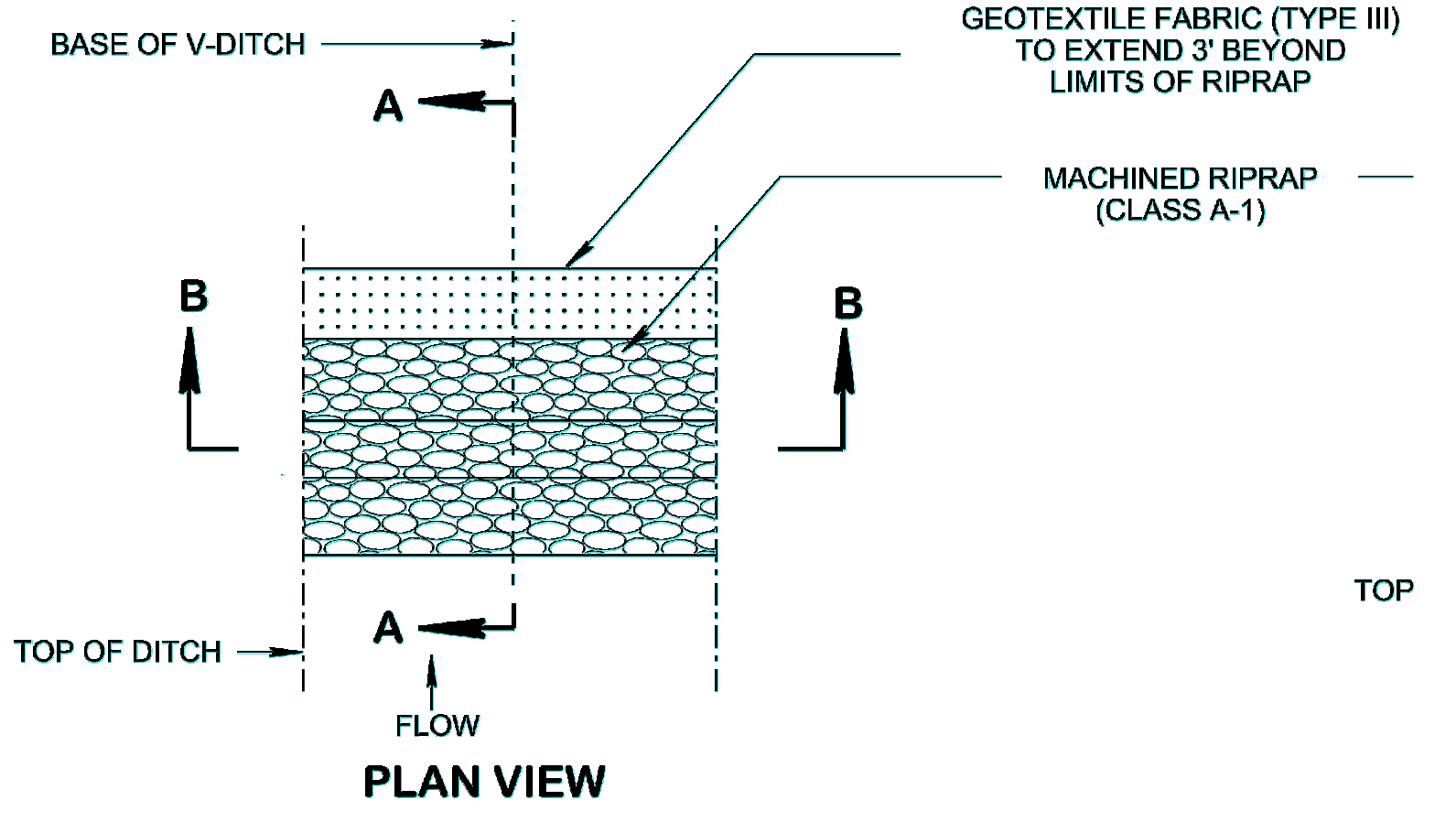

TDOT Classification	D <sub>50</sub> Stone Size (inches)	Overall Stone Sizes (inches)
Class A-1	9	2 - 15
Class A-3	4	2 - 6
Class B	15	3 - 27
Class C	20	5 - 36

ST SEDIMENT TRAP DETAIL

NOTE: SEE SHEET 2 FOR DIMENSIONS AND SPECIFICATIONS OF SEDIMENT TRAPS

PREFERRED SEEDING SCHEDULE

Zone	Best	Marginal	Preferred Rate/Mix (lb/ac PLS)
Region I	Poorly drained soils Feb 1 - Mar 20 Sept 1 - Sept 30	Mar 20 - Apr 30 Sept 30 - Oct 31	15 Browntop millet* (nurse crop) 2 switch grass 4 little bluestem 4 Virginia wild rye 4 purpletop 2 partridge pea 2 black-eyed susan
	Well drained soils Apr 1 - July 15		15 Browntop millet* (nurse crop) 4 little blue stem 4 purpletop 2 sideoats gramma 2 partridge pea 2 black-eyed susan
	High maintenance Apr 1 - July 15		15 Browntop millet* (nurse crop) 2 partridge pea 45 Red fescue* 45 hard fescue* 25 chewing fescue*
Region II	Low maintenance; Slopes and Poor, shallow soils Aug 25 - Sept 15 Feb 15 - May 30	Sept 15 - Oct 25 Mar 21 - May 30	15 Browntop millet* (nurse crop) 5 little bluestem 2 switch grass 2 tall dropseed 5 sideoats gramma 2 black-eyed susan 2 partridge pea 1 greyheaded coneflower
	Low maintenance; Moderate slopes; soils > 6 in. depth Aug 25 - Sept 15 Feb 15 - May 30	Sept 15 - Oct 25 Mar 21 - Apr 15	15 Browntop millet* (nurse crop) 5 purpletop 5 little bluestem 5 Virginia wild rye 2 black-eyed susan 2 partridge pea 1 greyheaded coneflower
	High maintenance Aug 30 - Oct 15	Feb 15 - Apr 15	15 Browntop millet* (nurse crop) 2 partridge pea 45 Red fescue* 45 hard fescue* 25 chewing fescue*
Region III	>2500 ft elevation; steep slopes Mar 20 - Apr 30	Aug 15 - Aug 30 Mar 1 - Mar 20 Apr 20 - June 15	15 Browntop millet* (nurse crop) 5 purpletop 10 little bluestem 10 Indian grass 2 black-eyed susan 0.5 monarda (bergamot) 4 Maryland senna
	<2500 ft elevation; steep slopes Aug 15 - Sept 1 Mar 1 - Apr 1	Sept 1 - Sept 15 Apr 1 - June 10	15 Browntop millet* (nurse crop) 4 purpletop 10 little bluestem 10 broomsedge 2 partridge pea 2 black-eyed susan 0.5 monarda (bergamot)
Region III cont'd	>2500 ft elev.; Shallow soils Mar 20 - Apr 20	Aug 15 - Aug 30 Mar 5 - Mar 20 Apr 20 - June 15	15 Browntop millet* (nurse crop) 4 purpletop 10 little bluestem 10 broomsedge 2 partridge pea 2 black-eyed susan 0.5 monarda (bergamot)
	<2500 ft elev.; Shallow soils Aug 15 - Sept 1 Mar 1 - Apr 1	Sept 1 - Sept 15 Apr 1 - June 10	15 Browntop millet* (nurse crop) 4 purpletop 10 Indian grass 2 black-eyed susan 0.5 monarda (bergamot) 4 Maryland senna
	>2500 ft elev.; Moderate slopes Mar 20 - Apr 20	Aug 15 - Aug 30 Mar 5 - Mar 20 Apr 20 - June 15	15 Browntop millet* (nurse crop) 4 purpletop 10 little bluestem 10 Indian grass
	<2500 ft elev.; Moderate slopes Aug 15 - Sept 1 Mar 1 - Apr 1	Sept 1 - Sept 15 Apr 1 - June 10	15 Browntop millet* (nurse crop) 45 Red fescue* 45 hard fescue* 25 chewing fescue*

ALLOWABLE SEEDING SCHEDULE

Zone	Best	Marginal	Rate/Mix (lb/ac PLS)
Region I	Poorly drained soils Feb 1 - Mar 20 Sept 1 - Sept 30	Mar 20 - Apr 30 Sept 30 - Oct 31	30 Pensacola bahiagrass 30 Bermudagrass (hulled) 20 Korean lespedeza** 10 Kobe lespedeza**
	Well drained soils Apr 1 - July 15		50 Pensacola bahiagrass 15 Bermudagrass (hulled) 30 Korean lespedeza** 15 Foxtail millet**
	High maintenance Apr 1 - July 15		40 Bermudagrass (hulled)
Region II	Low maintenance; Slopes and Poor, shallow soils Aug 25 - Sept 15 Feb 15 - Mar 21	Sept 15 - Oct 25 Mar 21 - Apr 15	100 Pensacola bahiagrass 40 Bermudagrass (hulled) 20 Korean lespedeza** 10 Kobe lespedeza**
	Low maintenance; Moderate slopes; soils > 6 in. depth Aug 25 - Sept 15 Feb 15 - Mar 21	Sept 15 - Oct 25 Mar 21 - Apr 15	30 Pensacola bahiagrass 30 Bermudagrass (hulled) 20 Korean lespedeza** 10 Kobe lespedeza**
	High maintenance Aug 15 - Oct 15	Feb 15 - Apr 15	200 KY 31 fescue**
Region III	>2500 ft elevation; steep slopes July 25 - Aug 15 Mar 20 - Apr 20	July 15 - July 25 Aug 15 - Aug 30 Mar 1 - Mar 20 Apr 20 - May 15	100 KY 31 fescue** 20 Kobe lespedeza** 10 Korean lespedeza** 5 Redtop
	<2500 ft elevation; steep slopes Aug 15 - Sept 1 Mar 1 - Apr 1	July 25 - Aug 15 Sept 1 - Sept 15 Apr 1 - May 10	40 KY 31 fescue** 10 Korean lespedeza** 10 Redtop
	>2500 ft elev.; Shallow soils July 25 - Aug 15 Mar 20 - Apr 20	July 15 - July 25 Aug 15 - Aug 30 Mar 5 - Mar 20 Apr 20 - May 15	40 KY 31 fescue** 10 Korean lespedeza** 10 Redtop
	<2500 ft elev.; Shallow soils Aug 15 - Sept 1 Mar 1 - Apr 1	July 25 - Aug 15 Sept 1 - Sept 15 Apr 1 - May 10	10 Crown vetch**
	>2500 ft elev.; Moderate slopes July 25 - Aug 15 Mar 20 - Apr 20	July 15 - July 25 Aug 15 - Aug 30 Mar 5 - Mar 20 Apr 20 - May 15	60 KY 31 fescue** 15 Korean lespedeza** 15 Kobe lespedeza**
	<2500 ft elev.; Moderate slopes Aug 15 - Sept 1 Mar 1 - Apr 1	July 25 - Aug 15 Sept 1 - Sept 15 Apr 1 - May 10	200 KY 31 fescue**

• Fertilizer:  
Grasses: 800-1200 lb/acre of 10-10-10 (or the equivalent)  
Grass-legume mixtures: 800-1200 lb/acre of 5-10-10 (or the equivalent)

PS PERMANENT SEEDING DETAIL

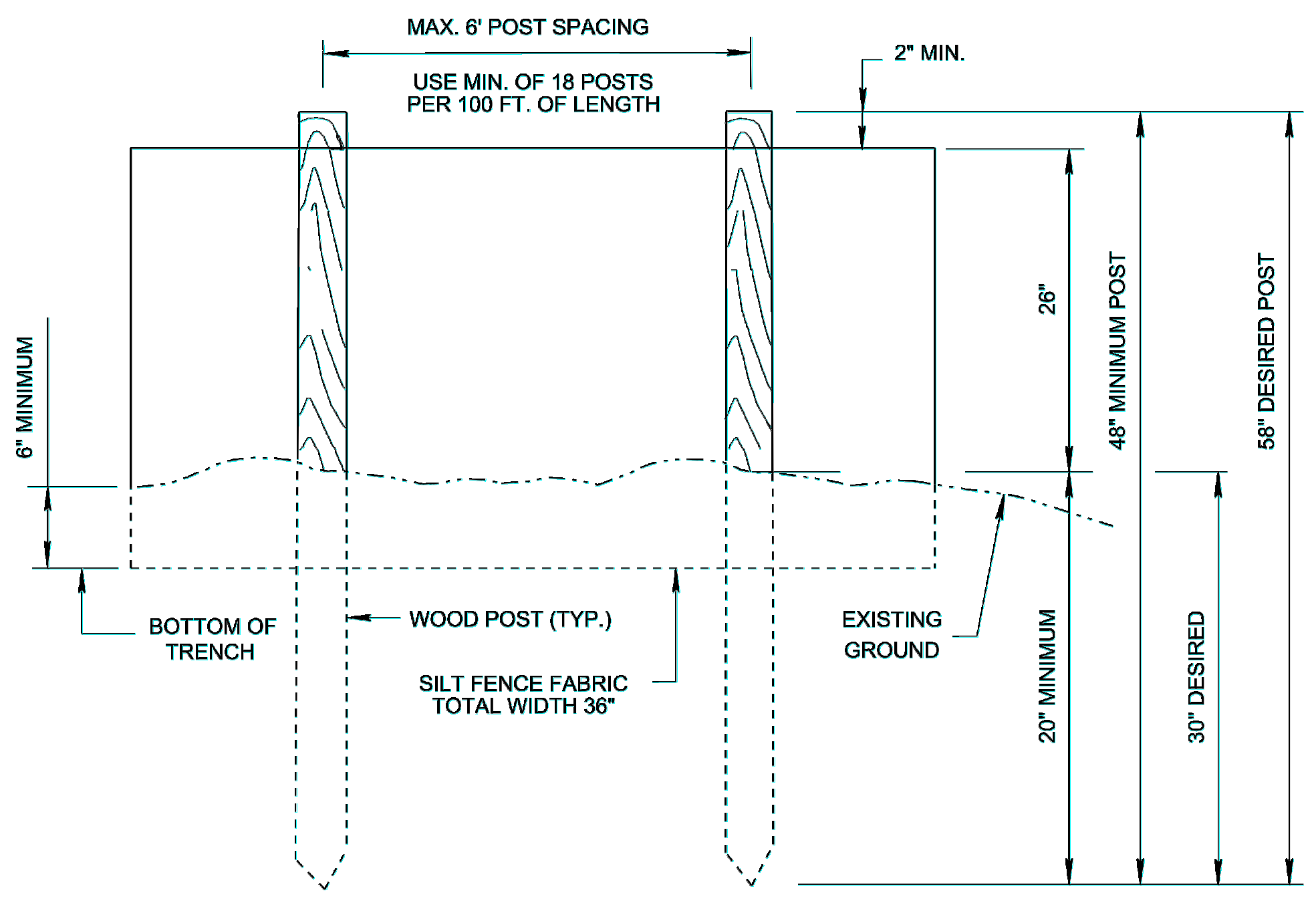

SD SILT FENCE DETAIL

DATE	
REVISION	

EROSION, SEDIMENT & POLLUTION CONTROL PLAN  
FOR  
TINY HOME LUXURY RESORT  
177 ROPER ROAD  
COPPERHILL, TN

PJS 9-18-23  
DRAWN BY DATE  
PJS 9-18-23  
CHECKED BY DATE

**DPDS DEVELOPMENT LLC**  
patrick@dpdsdevelopment.com  
(760) 977-8007



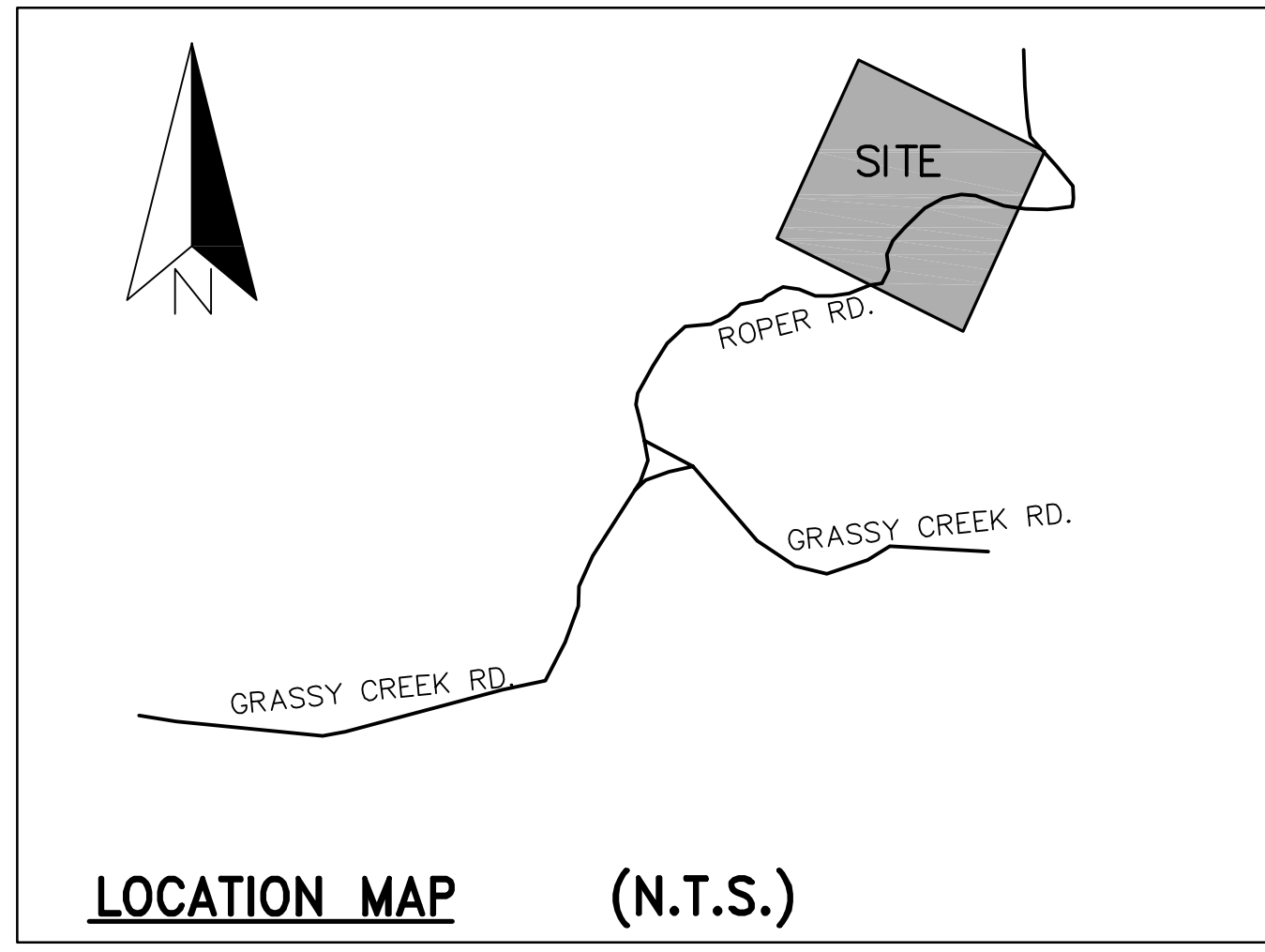
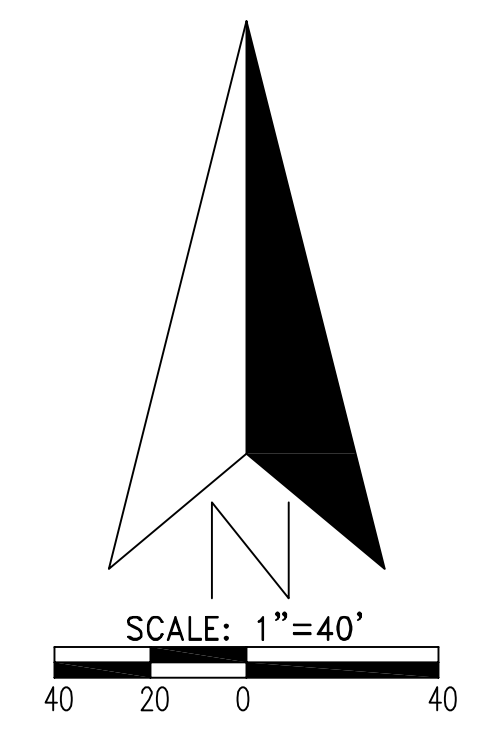
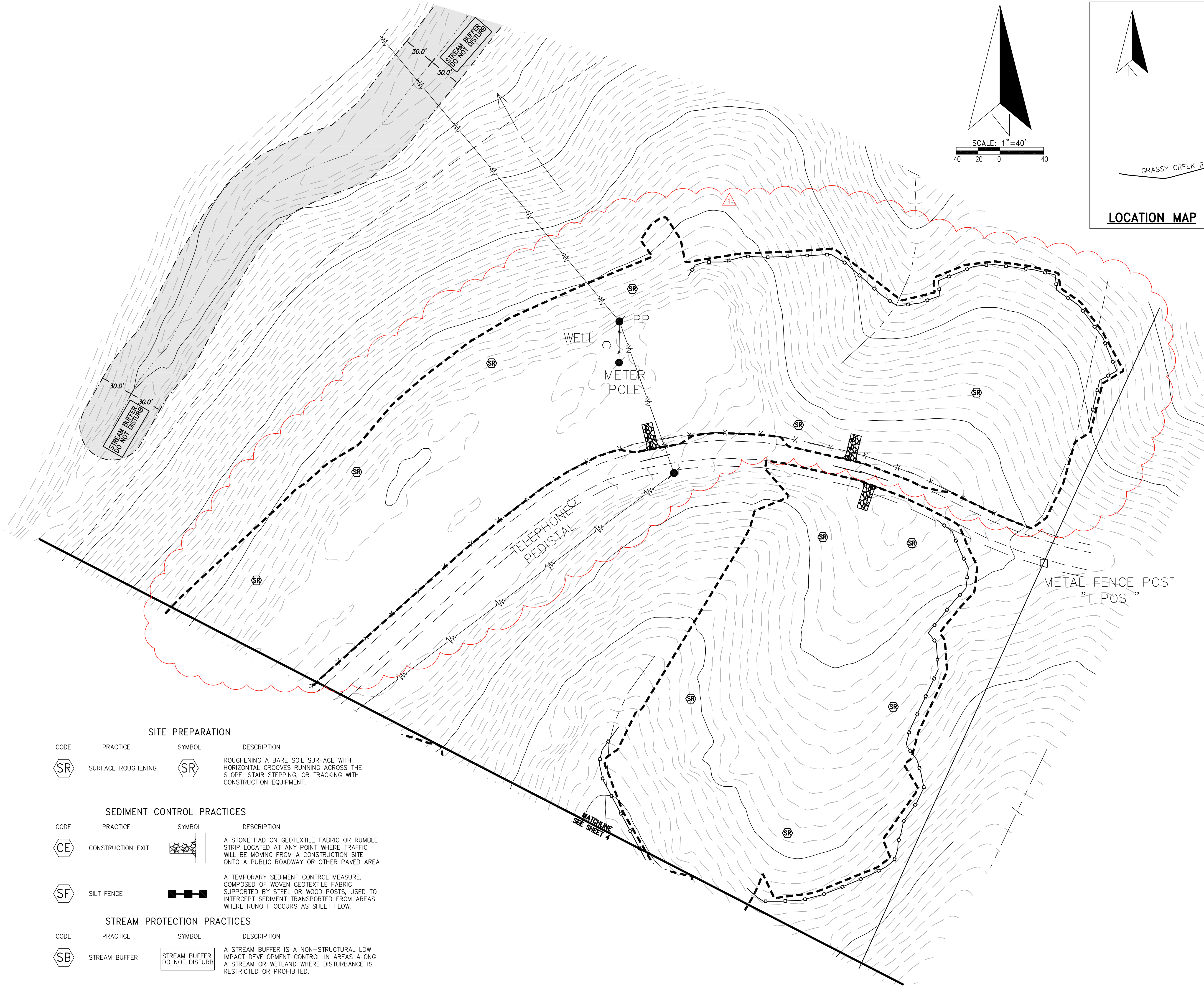

- ▲ CALCULATED POINT
- IRON PIN SET (IPS 1/2"RB)
- IRON PIN FOUND (I.P.F.)
- PROPERTY LINE
- RIDGE LINE
- x FENCE
- - - DITCH
- STREAM
- HOLLOW
- - - LAND LOT LINE (LLL)
- - - CENTERLINE
- - - POWERLINE
- TELEPHONE LINE
- - - DIRT ROAD
- - - GRAVEL ROAD
- TELE/POWER POLE
- TELE/ELEC BOX
- FENCE POST F.P.
- DEED BOOK
- P.B. PLAT BOOK
- L.L.C. LAND LOT CORNER
- NOT TO SCALE
- SOIL AUGER HOLE
- SOIL LIMITS
- BRANWARE 1/2-INCHES
- SOIL BOUNDARY
- SLOPE
- SLOPE
- SLOPE
- PROPOSED CONTOUR, 2-FT.
- PROPOSED CONTOUR, 10-FT.
- BLOCK WALL
- EDGE OF GRAVEL ROAD
- - - LIMITS OF DISTURBED AREA

SITE PREPARATION			
CODE	PRACTICE	SYMBOL	DESCRIPTION
SR	SURFACE ROUGHENING	SR	ROUGHENING A BARE SOIL SURFACE WITH HORIZONTAL GROOVES RUNNING ACROSS THE SLOPE, STAIR STEPPING, OR TRACKING WITH CONSTRUCTION EQUIPMENT.
SEDIMENT CONTROL PRACTICES			
CODE	PRACTICE	SYMBOL	DESCRIPTION
CE	CONSTRUCTION EXIT	CE	A STONE PAD ON GEOTEXTILE FABRIC OR RUMBLE STRIP LOCATED AT ANY POINT WHERE TRAFFIC WILL BE MOVING FROM A CONSTRUCTION SITE ONTO A PUBLIC ROADWAY OR OTHER PAVED AREA
SF	SILT FENCE	SF	A TEMPORARY SEDIMENT CONTROL MEASURE, COMPOSED OF WOVEN GEOTEXTILE FABRIC SUPPORTED BY STEEL OR WOOD POSTS, USED TO INTERCEPT SEDIMENT TRANSPORTED FROM AREAS WHERE RUNOFF OCCURS AS SHEET FLOW.
STREAM PROTECTION PRACTICES			
CODE	PRACTICE	SYMBOL	DESCRIPTION
SB	STREAM BUFFER	SB	A STREAM BUFFER IS A NON-STRUCTURAL LOW IMPACT DEVELOPMENT CONTROL IN AREAS ALONG A STREAM OR WETLAND WHERE DISTURBANCE IS RESTRICTED OR PROHIBITED.

REVISION  
REVISED SITE PLAN & EROSION MEASURES  
DATE  
12-11-23

INITIAL (CLEARING) PHASE FOR  
EROSION, SEDIMENT & POLLUTION CONTROL PLAN  
FOR  
TINY HOME LUXURY RESORT  
177 ROPER ROAD  
COPPERHILL, TN

PJS 9-18-23  
DRAWN BY DATE  
PJS 9-18-23  
CHECKED BY DATE

**DPS**  
DEVELOPMENT LLC  
patrick@dpsdevelopment.tn  
(760) 977-8007

SHEET  
5  
OF 9

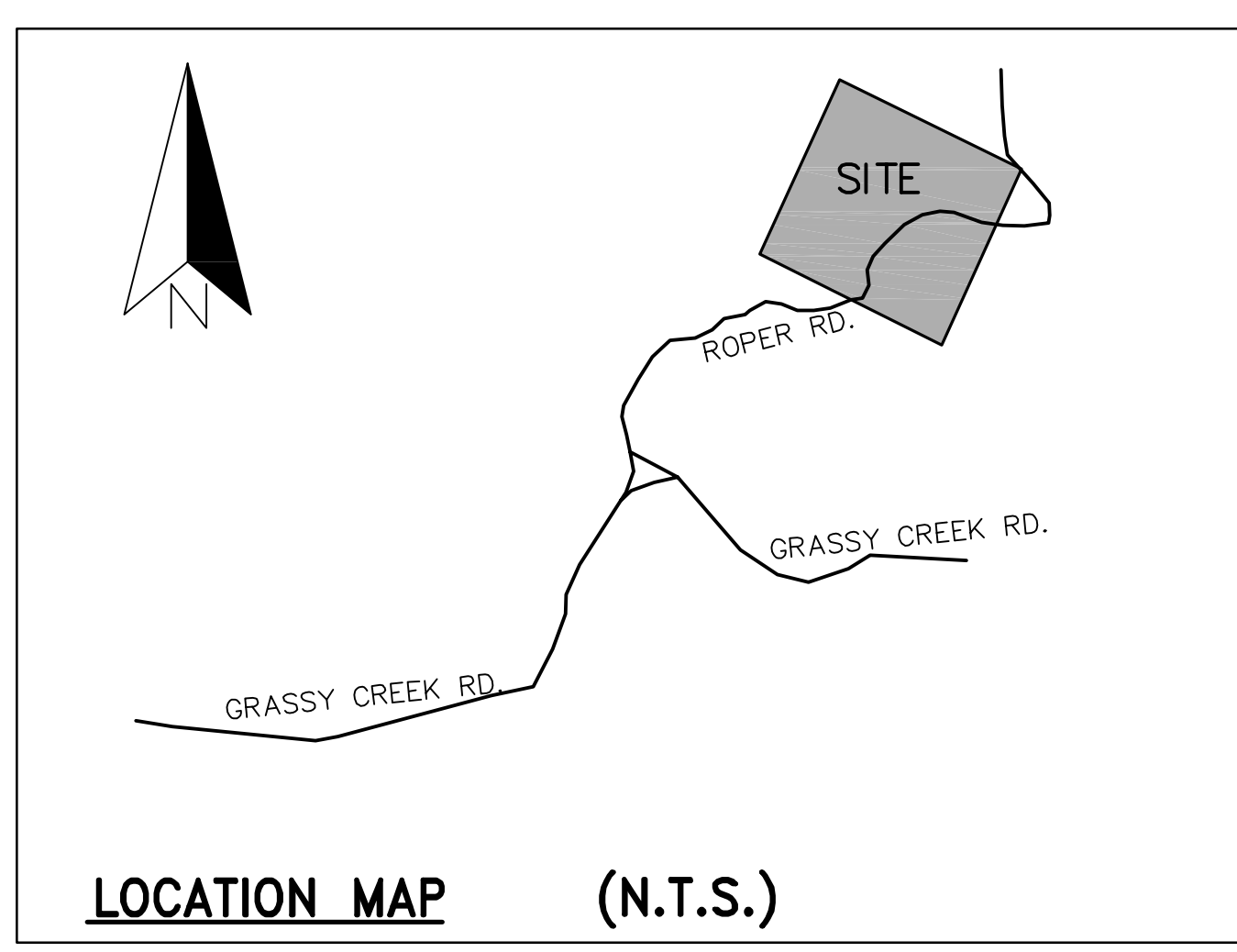
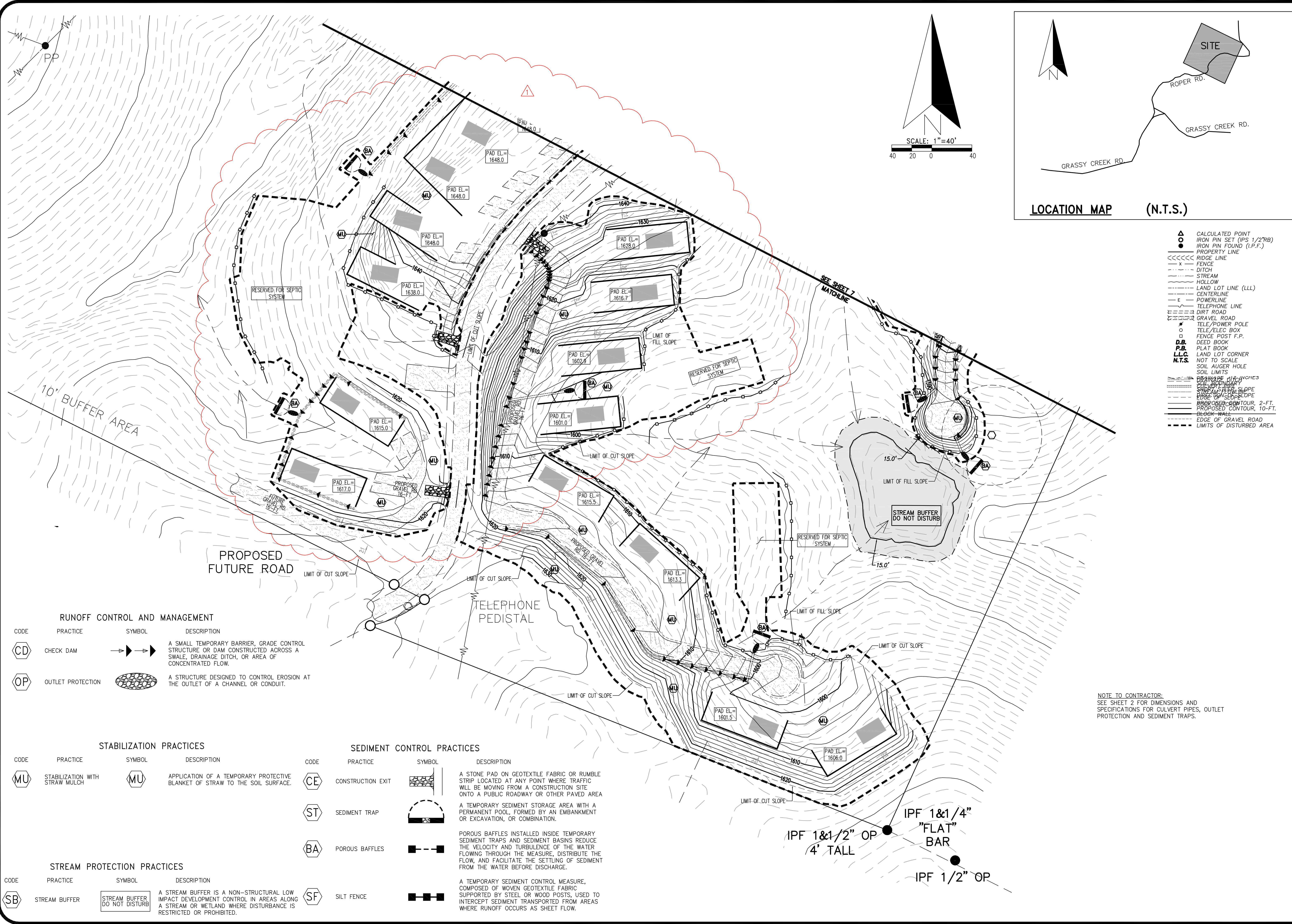

- ▲ CALCULATED POINT
- IRON PIN SET (IPS 1/2"RB)
- IRON PIN FOUND (I.P.F.)
- PROPERTY LINE
- RIDGE LINE
- x FENCE
- - - DITCH
- - - HOLLOW
- - - STREAM
- - - LAND LOT LINE (LL)
- - - CENTERLINE
- - - POWERLINE
- - - TELEPHONE LINE
- - - DIRT ROAD
- - - GRAVEL ROAD
- TELE/POWER POLE
- TELE/ELEC BOX
- FENCE POST F.P.
- DEED BOOK
- P.B. PLAT BOOK
- L.L.C. LAND LOT CORNER
- NOT TO SCALE
- SOIL AUGER HOLE
- SOIL LIMITS
- DRAINAGE 4" INCHES
- SOIL BOUNDARY
- SLOPE
- SLOPE
- SLOPE
- PROPOSED CONTOUR, 2-FT.
- PROPOSED CONTOUR, 10-FT.
- BLOCK WALL
- EDGE OF GRAVEL ROAD
- LIMITS OF DISTURBED AREA

**RUNOFF CONTROL AND MANAGEMENT**

CODE	PRACTICE	SYMBOL	DESCRIPTION
CD	CHECK DAM	→ → →	A SMALL TEMPORARY BARRIER, GRADE CONTROL STRUCTURE OR DAM CONSTRUCTED ACROSS A SWALE, DRAINAGE DITCH, OR AREA OF CONCENTRATED FLOW.
OP	OUTLET PROTECTION	⊘	A STRUCTURE DESIGNED TO CONTROL EROSION AT THE OUTLET OF A CHANNEL OR CONDUIT.

**STABILIZATION PRACTICES**

CODE	PRACTICE	SYMBOL	DESCRIPTION
MU	STABILIZATION WITH STRAW MULCH	MU	APPLICATION OF A TEMPORARY PROTECTIVE BLANKET OF STRAW TO THE SOIL SURFACE.
CE	CONSTRUCTION EXIT	—	A STONE PAD ON GEOTEXTILE FABRIC OR RUMBLE STRIP LOCATED AT ANY POINT WHERE TRAFFIC WILL BE MOVING FROM A CONSTRUCTION SITE ONTO A PUBLIC ROADWAY OR OTHER PAVED AREA
ST	SEDIMENT TRAP	—	A TEMPORARY SEDIMENT STORAGE AREA WITH A PERMANENT POOL, FORMED BY AN EMBANKMENT OR EXCAVATION, OR COMBINATION.
BA	POROUS BAFFLES	—	POROUS BAFFLES INSTALLED INSIDE TEMPORARY SEDIMENT TRAPS AND SEDIMENT BASINS REDUCE THE VELOCITY AND TURBULENCE OF THE WATER FLOWING THROUGH THE MEASURE, DISTRIBUTE THE FLOW, AND FACILITATE THE SETTLING OF SEDIMENT FROM THE WATER BEFORE DISCHARGE.

**STREAM PROTECTION PRACTICES**

CODE	PRACTICE	SYMBOL	DESCRIPTION
SB	STREAM BUFFER	—	A STREAM BUFFER IS A NON-STRUCTURAL LOW IMPACT DEVELOPMENT CONTROL IN AREAS ALONG A STREAM OR WETLAND WHERE DISTURBANCE IS RESTRICTED OR PROHIBITED.
SF	SILT FENCE	—	A TEMPORARY SEDIMENT CONTROL MEASURE, COMPOSED OF WOVEN GEOTEXTILE FABRIC SUPPORTED BY STEEL OR WOOD POSTS, USED TO INTERCEPT SEDIMENT TRANSPORTED FROM AREAS WHERE RUNOFF OCCURS AS SHEET FLOW.

**SEDIMENT CONTROL PRACTICES**

CODE	PRACTICE	SYMBOL	DESCRIPTION
CE	CONSTRUCTION EXIT	—	A STONE PAD ON GEOTEXTILE FABRIC OR RUMBLE STRIP LOCATED AT ANY POINT WHERE TRAFFIC WILL BE MOVING FROM A CONSTRUCTION SITE ONTO A PUBLIC ROADWAY OR OTHER PAVED AREA
ST	SEDIMENT TRAP	—	A TEMPORARY SEDIMENT STORAGE AREA WITH A PERMANENT POOL, FORMED BY AN EMBANKMENT OR EXCAVATION, OR COMBINATION.
BA	POROUS BAFFLES	—	POROUS BAFFLES INSTALLED INSIDE TEMPORARY SEDIMENT TRAPS AND SEDIMENT BASINS REDUCE THE VELOCITY AND TURBULENCE OF THE WATER FLOWING THROUGH THE MEASURE, DISTRIBUTE THE FLOW, AND FACILITATE THE SETTLING OF SEDIMENT FROM THE WATER BEFORE DISCHARGE.
SF	SILT FENCE	—	A TEMPORARY SEDIMENT CONTROL MEASURE, COMPOSED OF WOVEN GEOTEXTILE FABRIC SUPPORTED BY STEEL OR WOOD POSTS, USED TO INTERCEPT SEDIMENT TRANSPORTED FROM AREAS WHERE RUNOFF OCCURS AS SHEET FLOW.

NOTE TO CONTRACTOR:  
SEE SHEET 2 FOR DIMENSIONS AND SPECIFICATIONS FOR CULVERT PIPES, OUTLET PROTECTION AND SEDIMENT TRAPS.

REVISION	DATE
REVISED SITE PLAN & EROSION CONTROL MEASURES	12-11-23

INTERIM GRADING PHASE FOR  
EROSION, SEDIMENT & POLLUTION CONTROL PLAN  
FOR  
**TINY HOME LUXURY RESORT**  
177 ROPER ROAD  
COPPERHILL, TN

PJS	9-18-23
DRAWN BY	DATE
PJS	9-18-23
CHECKED BY	DATE

**DPS DEVELOPMENT LLC**  
patrick@dpsdevelopment.com  
(760) 977-8007

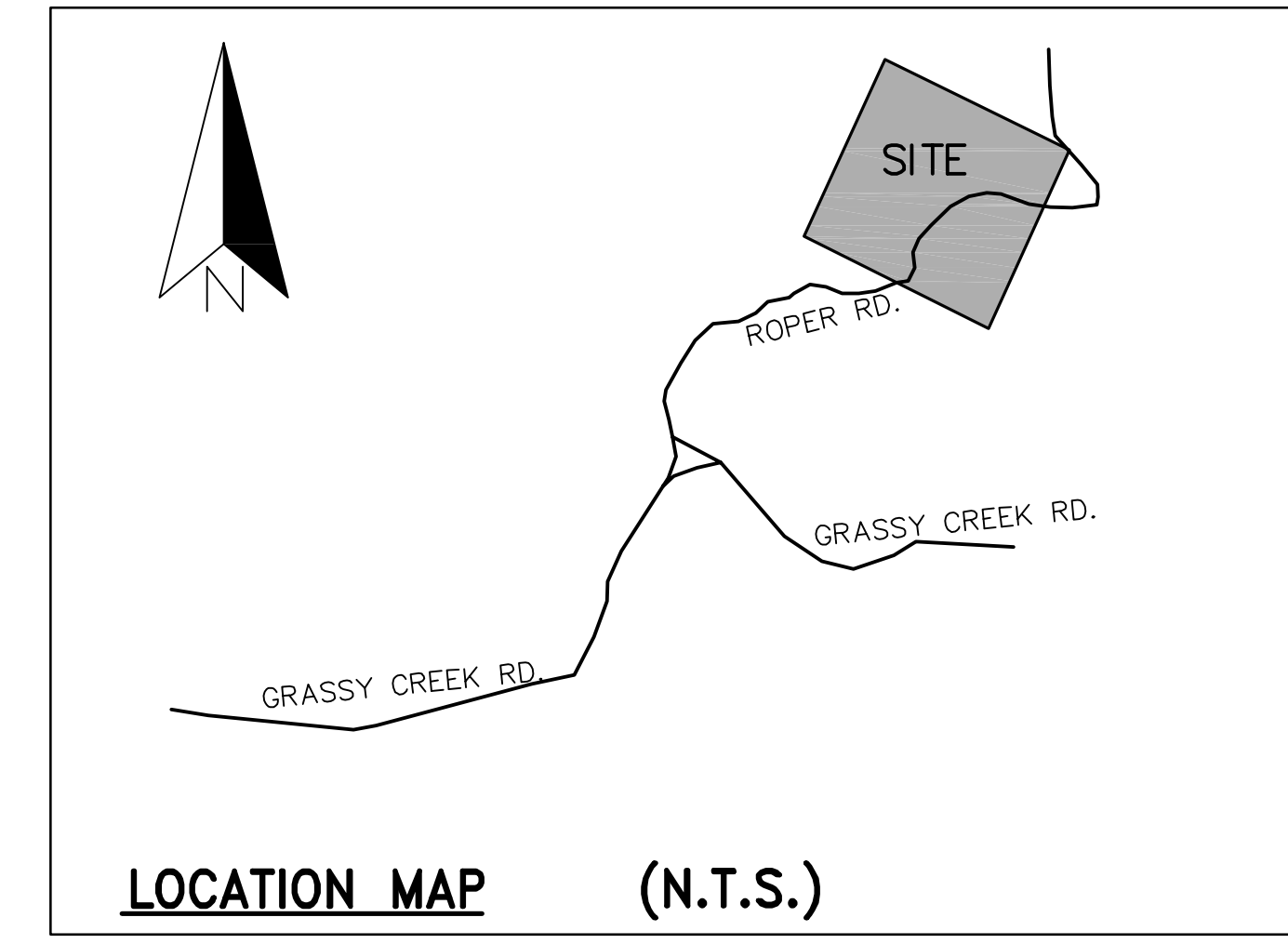
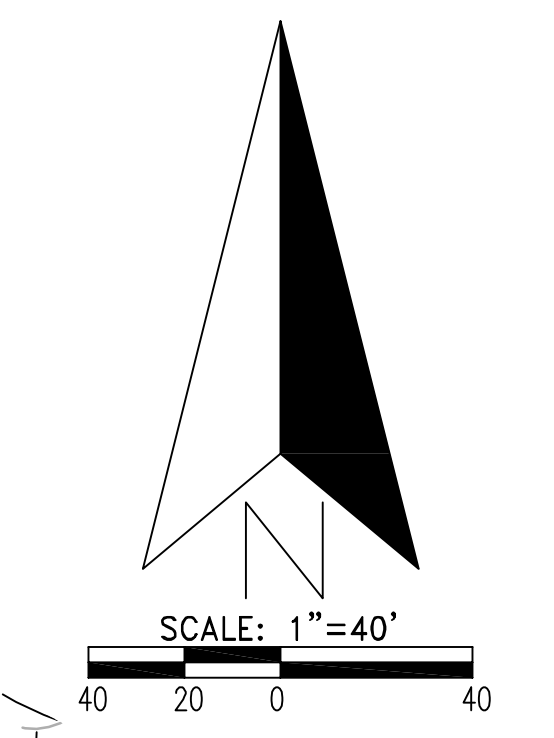
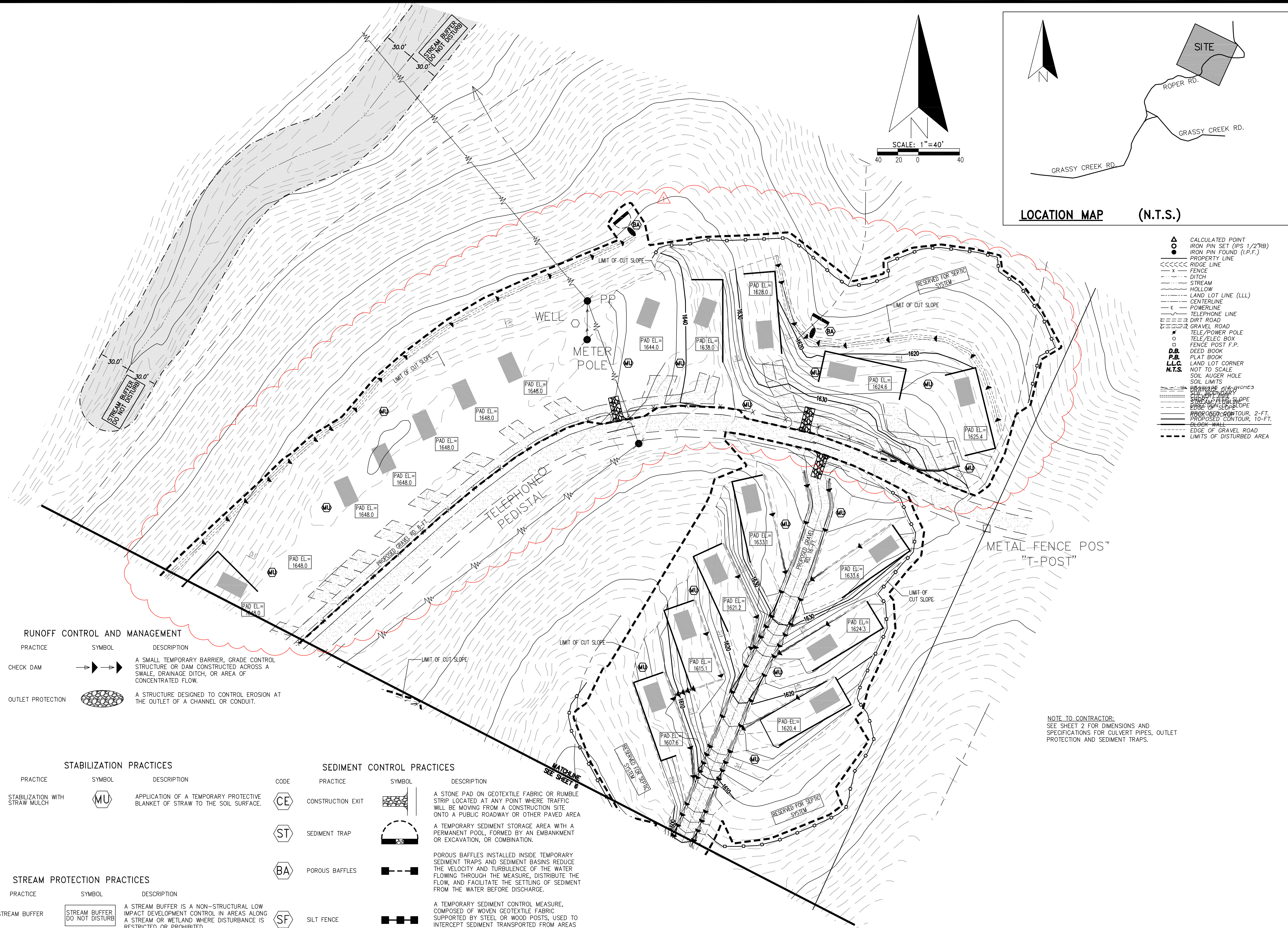

- ▲ CALCULATED POINT
- IRON PIN SET (IPS 1/2"RB)
- IRON PIN FOUND (I.P.F.)
- PROPERTY LINE
- RIDGE LINE
- x FENCE
- - - DITCH
- STREAM
- - - HOLLOW
- LAND LOT LINE (LL)
- CENTERLINE
- - - POWERLINE
- TELEPHONE LINE
- - - DIRT ROAD
- GRAVEL ROAD
- TELE/POWER POLE
- TELE/ELEC BOX
- FENCE POST F.P.
- DEED BOOK
- PLAT BOOK
- LAND LOT CORNER
- NOT TO SCALE
- SOIL AUGER HOLE
- SOIL LIMITS
- BRANWALL 4 INCHES
- SOIL BOUNDARY
- SLOPE
- SLOPE
- SLOPE
- PROPOSED CONTOUR, 2-FT.
- PROPOSED CONTOUR, 10-FT.
- BLOCK WALL
- EDGE OF GRAVEL ROAD
- LIMITS OF DISTURBED AREA

**RUNOFF CONTROL AND MANAGEMENT**

CODE	PRACTICE	SYMBOL	DESCRIPTION
CD	CHECK DAM	→ → →	A SMALL TEMPORARY BARRIER, GRADE CONTROL STRUCTURE OR DAM CONSTRUCTED ACROSS A SWALE, DRAINAGE DITCH, OR AREA OF CONCENTRATED FLOW.
OP	OUTLET PROTECTION	⊘	A STRUCTURE DESIGNED TO CONTROL EROSION AT THE OUTLET OF A CHANNEL OR CONDUIT.

**STABILIZATION PRACTICES**

CODE	PRACTICE	SYMBOL	DESCRIPTION
MU	STABILIZATION WITH STRAW MULCH	MU	APPLICATION OF A TEMPORARY PROTECTIVE BLANKET OF STRAW TO THE SOIL SURFACE.

**SEDIMENT CONTROL PRACTICES**

CODE	PRACTICE	SYMBOL	DESCRIPTION
CE	CONSTRUCTION EXIT	⊘	A STONE PAD ON GEOTEXTILE FABRIC OR RUMBLE STRIP LOCATED AT ANY POINT WHERE TRAFFIC WILL BE MOVING FROM A CONSTRUCTION SITE ONTO A PUBLIC ROADWAY OR OTHER PAVED AREA
ST	SEDIMENT TRAP	⊘	A TEMPORARY SEDIMENT STORAGE AREA WITH A PERMANENT POOL, FORMED BY AN EMBANKMENT OR EXCAVATION, OR COMBINATION.
BA	POROUS BAFFLES	—	POROUS BAFFLES INSTALLED INSIDE TEMPORARY SEDIMENT TRAPS AND SEDIMENT BASINS REDUCE THE VELOCITY AND TURBULENCE OF THE WATER FLOWING THROUGH THE MEASURE, DISTRIBUTE THE FLOW, AND FACILITATE THE SETTLING OF SEDIMENT FROM THE WATER BEFORE DISCHARGE.

**STREAM PROTECTION PRACTICES**

CODE	PRACTICE	SYMBOL	DESCRIPTION
SB	STREAM BUFFER	STREAM BUFFER DO NOT DISTURB	A STREAM BUFFER IS A NON-STRUCTURAL LOW IMPACT DEVELOPMENT CONTROL IN AREAS ALONG A STREAM OR WETLAND WHERE DISTURBANCE IS RESTRICTED OR PROHIBITED.

**SEDIMENT CONTROL PRACTICES**

CODE	PRACTICE	SYMBOL	DESCRIPTION
SF	SILT FENCE	—	A TEMPORARY SEDIMENT CONTROL MEASURE, COMPOSED OF WOVEN GEOTEXTILE FABRIC SUPPORTED BY STEEL OR WOOD POSTS, USED TO INTERCEPT SEDIMENT TRANSPORTED FROM AREAS WHERE RUNOFF OCCURS AS SHEET FLOW.

NOTE TO CONTRACTOR:  
SEE SHEET 2 FOR DIMENSIONS AND SPECIFICATIONS FOR CULVERT PIPES, OUTLET PROTECTION AND SEDIMENT TRAPS.

REVISION	DATE
REVISED SITE PLAN & ES&PC MEASURES	12-11-23

INTERIM GRADING PHASE FOR  
EROSION, SEDIMENT & POLLUTION CONTROL PLAN  
FOR  
TINY HOME LUXURY RESORT  
177 ROPER ROAD  
COPPERHILL, TN

PJS	9-18-23
DRAWN BY	DATE
PJS	9-18-23
CHECKED BY	DATE

**DPS DEVELOPMENT LLC**  
patrick@dpsdevelopment.com  
(760) 977-8007

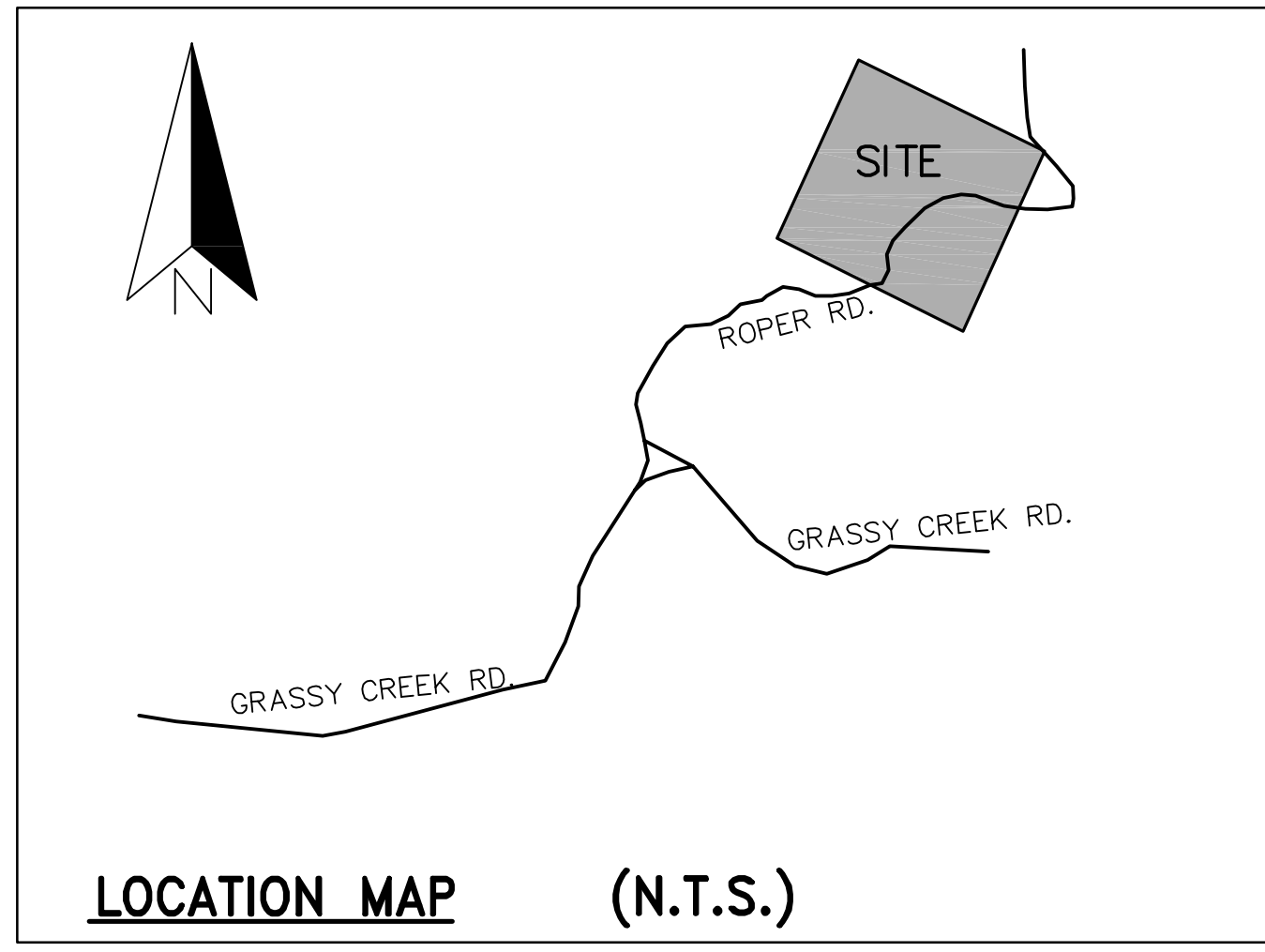
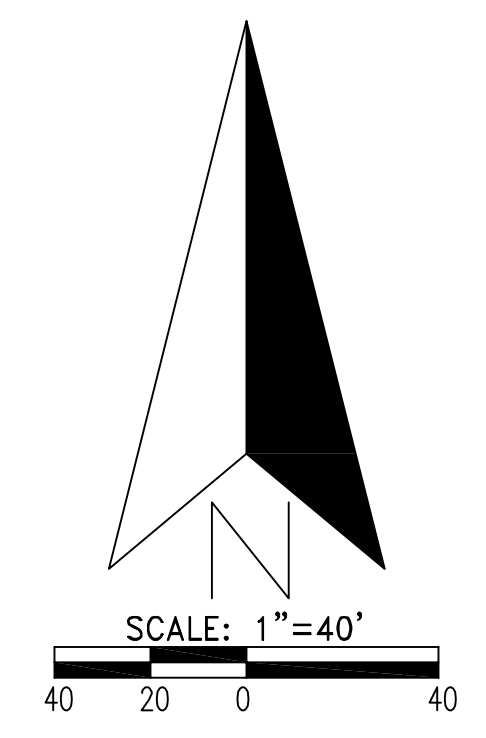
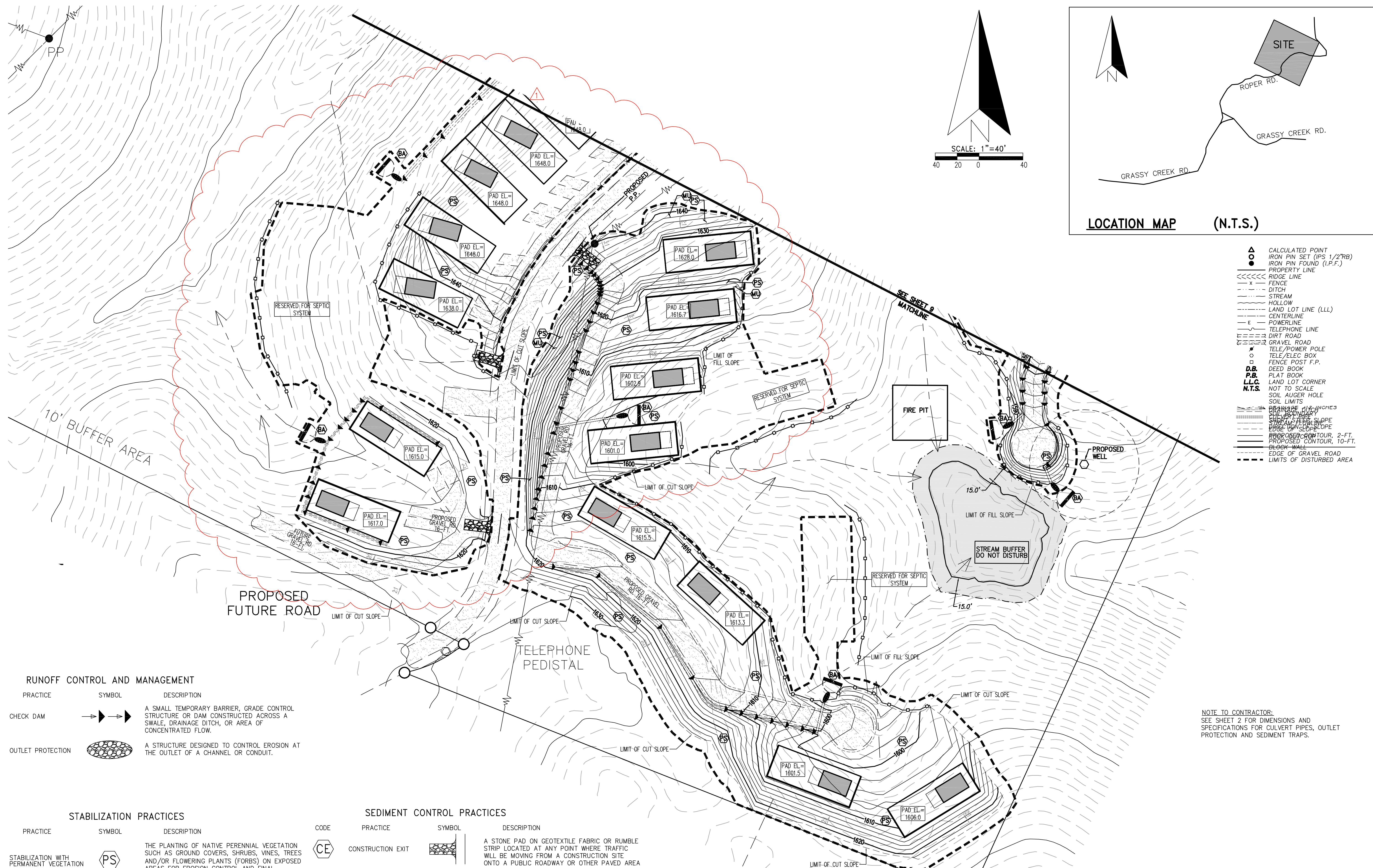

- ▲ CALCULATED POINT
- IRON PIN SET (IPS 1/2"RB)
- IRON PIN FOUND (I.P.F.)
- PROPERTY LINE
- RIDGE LINE
- x FENCE
- - - DITCH
- - - HOLLOW
- - - STREAM
- - - LAND LOT LINE (LL)
- - - CENTERLINE
- - - POWERLINE
- - - TELEPHONE LINE
- - - DIRT ROAD
- - - GRAVEL ROAD
- TELE/POWER POLE
- TELE/ELEC BOX
- FENCE POST F.P.
- DEED BOOK
- PLAT BOOK
- LAND LOT CORNER
- NOT TO SCALE
- SOIL AUGER HOLE
- SOIL LIMITS
- DRAINAGE (1/2" INCHES)
- SOIL BOUNDARY
- SLOPE
- SLOPE
- SLOPE
- PROPOSED CONTOUR, 2-FT.
- PROPOSED CONTOUR, 10-FT.
- BLOCK WALL
- EDGE OF GRAVEL ROAD
- LIMITS OF DISTURBED AREA

RUNOFF CONTROL AND MANAGEMENT			
CODE	PRACTICE	SYMBOL	DESCRIPTION
CD	CHECK DAM		A SMALL TEMPORARY BARRIER, GRADE CONTROL STRUCTURE OR DAM CONSTRUCTED ACROSS A SWALE, DRAINAGE DITCH, OR AREA OF CONCENTRATED FLOW.
OP	OUTLET PROTECTION		A STRUCTURE DESIGNED TO CONTROL EROSION AT THE OUTLET OF A CHANNEL OR CONDUIT.

STABILIZATION PRACTICES			
CODE	PRACTICE	SYMBOL	DESCRIPTION
PS	STABILIZATION WITH PERMANENT VEGETATION		THE PLANTING OF NATIVE PERENNIAL VEGETATION SUCH AS GROUND COVERS, SHRUBS, VINES, TREES AND/OR FLOWERING PLANTS (FORBS) ON EXPOSED AREAS FOR EROSION CONTROL AND FINAL STABILIZATION. PERMANENT PERENNIAL VEGETATION IS REQUIRED TO ACHIEVE FINAL STABILIZATION.

POLLUTION PREVENTION			
CODE	PRACTICE	SYMBOL	DESCRIPTION
CW	CONCRETE WASHOUT		A DESIGNATED AREA WHERE CONCRETE WASH CAN HARDEN, CAN BE BROKEN UP, AND CAN THEN BE PLACED IN THE DUMPSTER OF BACKFILLED.
TM	TRASH & DEBRIS MANAGEMENT		THE MANAGEMENT OF WASTE MATERIALS AND DEBRIS ON THE CONSTRUCTION SITE.

SEDIMENT CONTROL PRACTICES			
CODE	PRACTICE	SYMBOL	DESCRIPTION
CE	CONSTRUCTION EXIT		A STONE PAD ON GEOTEXTILE FABRIC OR RUMBLE STRIP LOCATED AT ANY POINT WHERE TRAFFIC WILL BE MOVING FROM A CONSTRUCTION SITE ONTO A PUBLIC ROADWAY OR OTHER PAVED AREA
ST	SEDIMENT TRAP		A TEMPORARY SEDIMENT STORAGE AREA WITH A PERMANENT POOL, FORMED BY AN EMBANKMENT OR EXCAVATION, OR COMBINATION.
BA	POROUS BAFFLES		POROUS BAFFLES INSTALLED INSIDE TEMPORARY SEDIMENT TRAPS AND SEDIMENT BASINS REDUCE THE VELOCITY AND TURBULENCE OF THE WATER FLOWING THROUGH THE MEASURE, DISTRIBUTE THE FLOW, AND FACILITATE THE SETTLING OF SEDIMENT FROM THE WATER BEFORE DISCHARGE.
SF	SILT FENCE		A TEMPORARY SEDIMENT CONTROL MEASURE, COMPOSED OF WOVEN GEOTEXTILE FABRIC SUPPORTED BY STEEL OR WOOD POSTS, USED TO INTERCEPT SEDIMENT TRANSPORTED FROM AREAS WHERE RUNOFF OCCURS AS SHEET FLOW.

STREAM PROTECTION PRACTICES			
CODE	PRACTICE	SYMBOL	DESCRIPTION
SB	STREAM BUFFER		A STREAM BUFFER IS A NON-STRUCTURAL LOW IMPACT DEVELOPMENT CONTROL IN AREAS ALONG A STREAM OR WETLAND WHERE DISTURBANCE IS RESTRICTED OR PROHIBITED.

NOTE TO CONTRACTOR:  
SEE SHEET 2 FOR DIMENSIONS AND SPECIFICATIONS FOR CULVERT PIPES, OUTLET PROTECTION AND SEDIMENT TRAPS.

FINAL PHASE FOR  
EROSION, SEDIMENT & POLLUTION CONTROL PLAN  
FOR  
TINY HOME LUXURY RESORT  
177 ROPER ROAD  
COPPERHILL, TN

PJS	9-18-23
DRAWN BY	DATE
PJS	9-18-23
CHECKED BY	DATE

REVISION	DATE
MEASURES	12-11-23



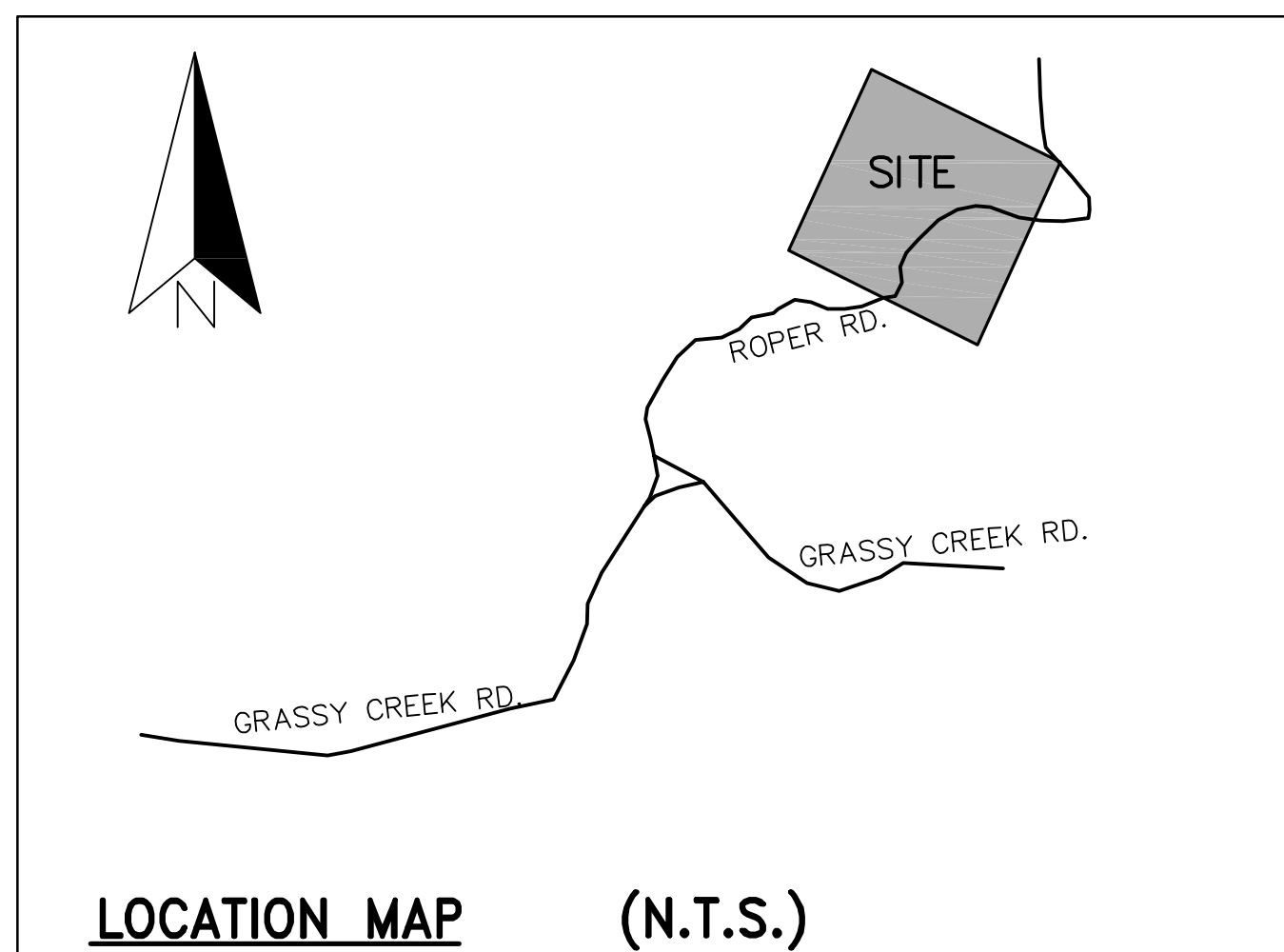
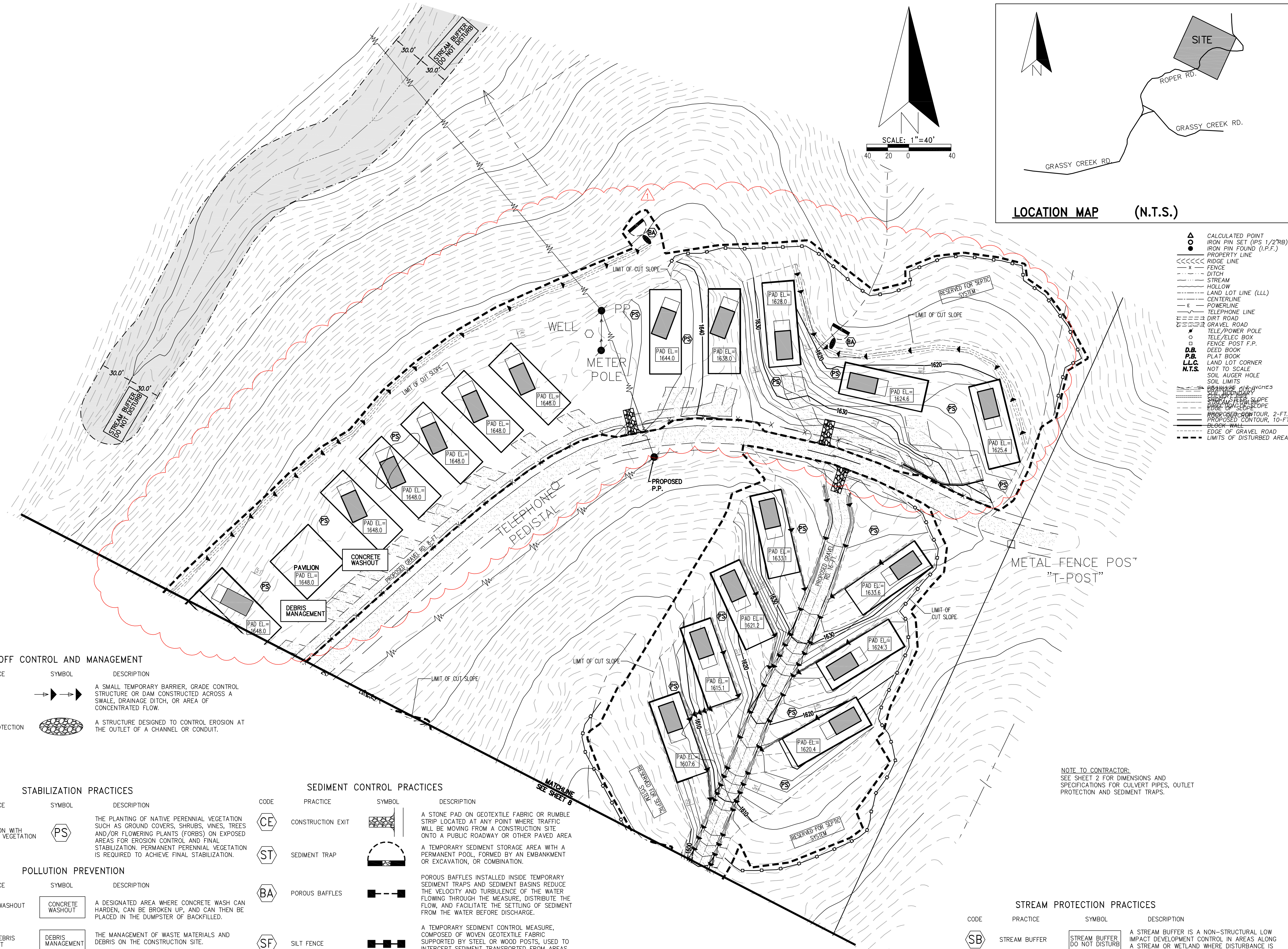

- ▲ CALCULATED POINT
- IRON PIN SET (IPS 1/2"RB)
- IRON PIN FOUND (I.P.F.)
- PROPERTY LINE
- RIDGE LINE
- x FENCE
- - - DITCH
- STREAM
- HOLLOW
- LAND LOT LINE (LLL)
- CENTERLINE
- POWERLINE
- TELEPHONE LINE
- - - DIRT ROAD
- GRAVEL ROAD
- TELE/POWER POLE
- TELE/ELEC BOX
- FENCE POST F.P.
- DEED BOOK
- PLAT BOOK
- LAND LOT CORNER
- NOT TO SCALE
- SOIL AUGER HOLE
- SOIL LIMITS
- DRAINAGE DIVISIONS
- COLLECTOR DRAIN
- CULVERT
- STREAM FEELING SLOPE
- EDGE OF SLOPE
- PROPOSED CONTOUR, 2-FT.
- PROPOSED CONTOUR, 10-FT.
- BLOCK WALL
- EDGE OF GRAVEL ROAD
- - - LIMITS OF DISTURBED AREA

RUNOFF CONTROL AND MANAGEMENT			
CODE	PRACTICE	SYMBOL	DESCRIPTION
CD	CHECK DAM	→ → →	A SMALL TEMPORARY BARRIER, GRADE CONTROL STRUCTURE OR DAM CONSTRUCTED ACROSS A SWALE, DRAINAGE DITCH, OR AREA OF CONCENTRATED FLOW.
OP	OUTLET PROTECTION	⊘	A STRUCTURE DESIGNED TO CONTROL EROSION AT THE OUTLET OF A CHANNEL OR CONDUIT.

STABILIZATION PRACTICES			
CODE	PRACTICE	SYMBOL	DESCRIPTION
PS	STABILIZATION WITH PERMANENT VEGETATION	⬡	THE PLANTING OF NATIVE PERENNIAL VEGETATION SUCH AS GROUND COVERS, SHRUBS, VINES, TREES AND/OR FLOWERING PLANTS (FORBS) ON EXPOSED AREAS FOR EROSION CONTROL AND FINAL STABILIZATION. PERMANENT PERENNIAL VEGETATION IS REQUIRED TO ACHIEVE FINAL STABILIZATION.

POLLUTION PREVENTION			
CODE	PRACTICE	SYMBOL	DESCRIPTION
CW	CONCRETE WASHOUT	CONCRETE WASHOUT	A DESIGNATED AREA WHERE CONCRETE WASH CAN HARDEN, CAN BE BROKEN UP, AND CAN THEN BE PLACED IN THE DUMPSTER OF BACKFILLED.
TM	TRASH & DEBRIS MANAGEMENT	DEBRIS MANAGEMENT	THE MANAGEMENT OF WASTE MATERIALS AND DEBRIS ON THE CONSTRUCTION SITE.

SEDIMENT CONTROL PRACTICES			
CODE	PRACTICE	SYMBOL	DESCRIPTION
CE	CONSTRUCTION EXIT	⊘	A STONE PAD ON GEOTEXTILE FABRIC OR RUMBLE STRIP LOCATED AT ANY POINT WHERE TRAFFIC WILL BE MOVING FROM A CONSTRUCTION SITE ONTO A PUBLIC ROADWAY OR OTHER PAVED AREA
ST	SEDIMENT TRAP	⊘	A TEMPORARY SEDIMENT STORAGE AREA WITH A PERMANENT POOL, FORMED BY AN EMBANKMENT OR EXCAVATION, OR COMBINATION.
BA	POROUS BAFFLES	— — —	POROUS BAFFLES INSTALLED INSIDE TEMPORARY SEDIMENT TRAPS AND SEDIMENT BASINS REDUCE THE VELOCITY AND TURBULENCE OF THE WATER FLOWING THROUGH THE MEASURE, DISTRIBUTE THE FLOW, AND FACILITATE THE SETTLING OF SEDIMENT FROM THE WATER BEFORE DISCHARGE.
SF	SILT FENCE	— — —	A TEMPORARY SEDIMENT CONTROL MEASURE, COMPOSED OF WOVEN GEOTEXTILE FABRIC SUPPORTED BY STEEL OR WOOD POSTS, USED TO INTERCEPT SEDIMENT TRANSPORTED FROM AREAS WHERE RUNOFF OCCURS AS SHEET FLOW.

NOTE TO CONTRACTOR:  
SEE SHEET 2 FOR DIMENSIONS AND SPECIFICATIONS FOR CULVERT PIPES, OUTLET PROTECTION AND SEDIMENT TRAPS.

STREAM PROTECTION PRACTICES			
CODE	PRACTICE	SYMBOL	DESCRIPTION
SB	STREAM BUFFER	STREAM BUFFER DO NOT DISTURB	A STREAM BUFFER IS A NON-STRUCTURAL LOW IMPACT DEVELOPMENT CONTROL IN AREAS ALONG A STREAM OR WETLAND WHERE DISTURBANCE IS RESTRICTED OR PROHIBITED.

FINAL PHASE FOR  
EROSION, SEDIMENT & POLLUTION CONTROL PLAN  
FOR  
TINY HOME LUXURY RESORT  
177 ROPER ROAD  
COPPERHILL, TN

PJS 9-18-23  
DRAWN BY DATE  
PJS 9-18-23  
CHECKED BY DATE

REVISION	DATE
REVISED SITE PLAN & ESI&PC MEASURES	12-11-23

## FW: Notice of Coverage: TNR114112 - Tiny Home Resort

Nikki Carpenter <Nikki.Carpenter@tn.gov>

Mon 12/11/2023 3:05 PM

To: Cali Calderwood <Cali.Calderwood@tn.gov>; Hannah L. Biggs <Hannah.L.Biggs@tn.gov>

Please upload, let me know if it doesn't open



**Nikki Carpenter** | Environmental Scientist

Division of Water Resources

Chattanooga Environmental Field Office

1301 Riverfront Parkway, Suite 206

Chattanooga, TN 37402

(423) 661-5267

[Nikki.Carpenter@tn.gov](mailto:Nikki.Carpenter@tn.gov)

[tn.gov/environment](http://tn.gov/environment)

---

**From:** Patrick Salcedo <patrick@dpsdevelopment.land>

**Sent:** Monday, December 11, 2023 12:10 PM

**To:** Nikki Carpenter <Nikki.Carpenter@tn.gov>

**Cc:** Jennifer Innes <Jennifer.Innes@tn.gov>; Robert Nix <robert\_nix73@hotmail.com>; Bo Oglesby <bo.oglesby@yahoo.com>; David Toole <davetoole2000@yahoo.com>

**Subject:** [EXTERNAL] RE: Notice of Coverage: TNR114112 - Tiny Home Resort

Hi Nikki,

Please see the link below to access the revised ES&PC plans for TNR114112. The disturbed area did in fact increase by 3.6% which I noted on the cover sheet. As mentioned, the ES&PC measures did not change much, just shifting a few things around like the sediment traps and the ditches flowing to the traps.

Let me know if you need anything else.

<https://www.dropbox.com/scl/fo/963hbxxgm34qxy6uyjff/h?rlkey=1pppwh5dw22n2b7hwpvem1ww3&dl=0>

Thank you!

**Patrick J. Salcedo, PE**

M: (760) 977-8007

<https://www.dpsdevelopment.land/>

---

**From:** Nikki Carpenter <[Nikki.Carpenter@tn.gov](mailto:Nikki.Carpenter@tn.gov)>

**Sent:** Wednesday, November 22, 2023 10:31 AM

**To:** Patrick Salcedo <[patrick@dpsdevelopment.land](mailto:patrick@dpsdevelopment.land)>

**Cc:** Jennifer Innes <[Jennifer.Innes@tn.gov](mailto:Jennifer.Innes@tn.gov)>

**Subject:** RE: Notice of Coverage: TNR114112 - Tiny Home Resort

Patrick,

I left you a voicemail in response, and I'm following up here with some options.

If the proposed revisions are *within* the permitted disturbed area, you don't need to send anything to us for review. The most up to date SWPPP (to include revised EPSC sheets) needs to be kept on site and adhered to by the site contractor. These revisions should meet the conditions of the CGP.

If the proposed work is outside the LOD currently permitted under a valid NOC, the permit allows you to increase the disturbed acreage by 10% . You don't need to submit an application, but you do need to submit a revised SWPPP for review.

If the acreage exceeds the 10%, a new submittal should be sent in for review and a new tracking number will be assigned.

Of course, all this changes if there are proposed impacts to jurisdictional features, buffer encroachments, or equivalent measures proposed. We may need to discuss further if that is the case.

Right now, work is only authorized inside the permitted LOD.

I will be available the rest of today, but then out of the office until next Wednesday. I've copied Jennifer in case this email doesn't address your concerns.

Thank you,



**Nikki Carpenter** | Environmental Scientist  
Division of Water Resources  
Chattanooga Environmental Field Office  
1301 Riverfront Parkway, Suite 206  
Chattanooga, TN 37402  
(423) 661-5267  
[Nikki.Carpenter@tn.gov](mailto:Nikki.Carpenter@tn.gov)  
[tn.gov/environment](http://tn.gov/environment)

---

**From:** Patrick Salcedo <[patrick@dpsdevelopment.land](mailto:patrick@dpsdevelopment.land)>  
**Sent:** Tuesday, November 21, 2023 4:40 PM  
**To:** Nikki Carpenter <[Nikki.Carpenter@tn.gov](mailto:Nikki.Carpenter@tn.gov)>  
**Subject:** [EXTERNAL] RE: Notice of Coverage: TNR114112 - Tiny Home Resort

**\*\*\* This is an EXTERNAL email. Please exercise caution. DO NOT open attachments or click links from unknown senders or unexpected email - STS-Security. \*\*\***

Hi Nikki,

I just left you a message about a site plan change for this project. The owners have decided to move a few homes around where the disturbed area will be relatively the same but it will affect the location of certain erosion control measures. I'd like to get your suggestion on how we care take care of this since the NOC has already been issued. Do we need to make this change to the plans now? Or can we start construction and submit plans sometime in the next month or so as we are clearing?

Thank you and regards,

**Patrick J. Salcedo, PE**

M: (760) 977-8007

<https://www.dpsdevelopment.land/>

---

**From:** Nikki Carpenter <[Nikki.Carpenter@tn.gov](mailto:Nikki.Carpenter@tn.gov)>

**Sent:** Wednesday, November 1, 2023 2:33 PM

**To:** [robert\\_nix73@hotmail.com](mailto:robert_nix73@hotmail.com)

**Cc:** Patrick Salcedo <[patrick@dpsdevelopment.land](mailto:patrick@dpsdevelopment.land)>

**Subject:** Notice of Coverage: TNR114112 - Tiny Home Resort

Please find attached the Notice of Coverage (NOC) for the above referenced project.

The NOC and other permit documents can also be found on the TDEC Public Data Viewer:  
[https://dataviewers.tdec.tn.gov/pls/enf\\_reports/f?p=9034:34001](https://dataviewers.tdec.tn.gov/pls/enf_reports/f?p=9034:34001)

We appreciate your attention to the General Construction Stormwater Permit (CGP) and its requirements. We believe this does make a difference to the quality of state waters. If you have any questions, please feel free to contact me.

NPDES Construction Stormwater Permit: <https://www.tn.gov/content/tn/environment/permit-permits/water-permits1/npdes-permits1/npdes-stormwater-permitting-program/npdes-stormwater-construction-permit.html>

Thank you,



**Nikki Carpenter** | Environmental Scientist

Division of Water Resources

Chattanooga Environmental Field Office

1301 Riverfront Parkway, Suite 206

Chattanooga, TN 37402

(423) 661-5267

[Nikki.Carpenter@tn.gov](mailto:Nikki.Carpenter@tn.gov)

[tn.gov/environment](https://tn.gov/environment)