



March 10, 2022

Mr. Leigh Yates, Environmental Consultant  
Knoxville Environmental Field Office  
TDEC Division of Water Resources  
3711 Middlebrook Pike  
Knoxville, TN 37921

Dear Mr. Yates:

Subject: Corrective Action Plan (CAP)  
Smoky Mountain Outdoors Unlimited, Inc. – Jennette Property Driveway  
Sevier County, Tennessee  
NPDES Permit #TNR136379  
CEC Project 303-786

Smoky Mountain Outdoors Unlimited (Owner) contracted Civil & Environmental Consultants, Inc. (CEC) to assist with addressing the Corrective Action Plan (CAP) requirement. The on-site visit by a TDEC representative on March 2, 2022, determined the scope of the CAP requirements.

In September 2021, CEC provided grading plans to the contractor, but the drawings did not include fill dirt material to be placed adjacent to the stream in question. See Exhibit A for reference to the original grading plan.

On March 2, 2022, Rodney McCarter, CEC Principal, and Andrew Atchley, CEC Staff Consultant, conducted a field visit to review potential violations of the NPDES Permit. Based on the existing topography, approximately 0.48 acres of fill dirt was placed in two different locations (see Exhibit B for location references) along the stream. The fill dirt rerouted the existing stream for approximately 250 feet at Location 2. Erosion prevention efforts such as silt fence was installed prior to this visit at the problematic locations. At Location 1, the fill dirt did not alter the existing stream, but the fill dirt encroached on the existing stream buffer.

With regards to Location 1, removal of all soil fill within 15 feet of stream bank and revegetation with an approved seed mixture is recommended to stabilize the disturbed area to a condition similar to the natural and undisturbed conditions on the property. Soil fill slope must not exceed 2:1 (see Exhibit C). At Location 2, a graded bench is recommended (see Exhibit C) to slow the runoff before it enters the stream in addition to the revegetation seeding and erosion stabilization efforts.

The proposed CAP outlined below is based on assessment of field observations and the data available to date. The proposed CAP is submitted on behalf of the Owner in order to comply with the requirements given by TDEC.

**Proposed Corrective Action Plan**

1. All appropriate permit coverage must be verified and obtained from appropriate Regulatory Agencies prior to beginning work.
2. At Location 1, all fill material must be removed within 15 feet of the stream bank to the depth of the pre-disturbance ground elevation.
3. At Location 2, a bench must be added in accordance to Exhibit C.
4. Disturbed areas must be permanently stabilized with an approved seed mix and straw mulch.
5. Work will be completed within 60 days of CAP approval and after required permit coverage (if any) is obtained.

Feel free to contact either of us with any questions or concerns regarding this submittal. We can be reached at 1-865-774-7771 or by email at [jpuckett@cecinc.com](mailto:jpuckett@cecinc.com) or [rjmccarter@cecinc.com](mailto:rjmccarter@cecinc.com).

Sincerely,

CIVIL & ENVIRONMENTAL CONSULTANTS, INC.

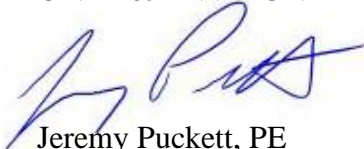

Jeremy Puckett, PE  
Project Manager



Rod McCarter, RLS  
Principal

Attachments

cc: Mr. Daniel Jennette, Smoky Mountain Outdoors Unlimited, Inc.  
File

---

**EXHIBIT A:  
ORIGINAL EPSC PLANS**

---

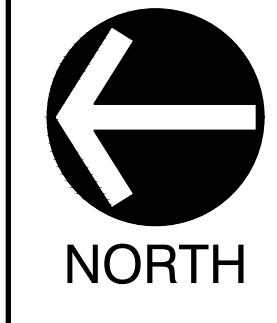
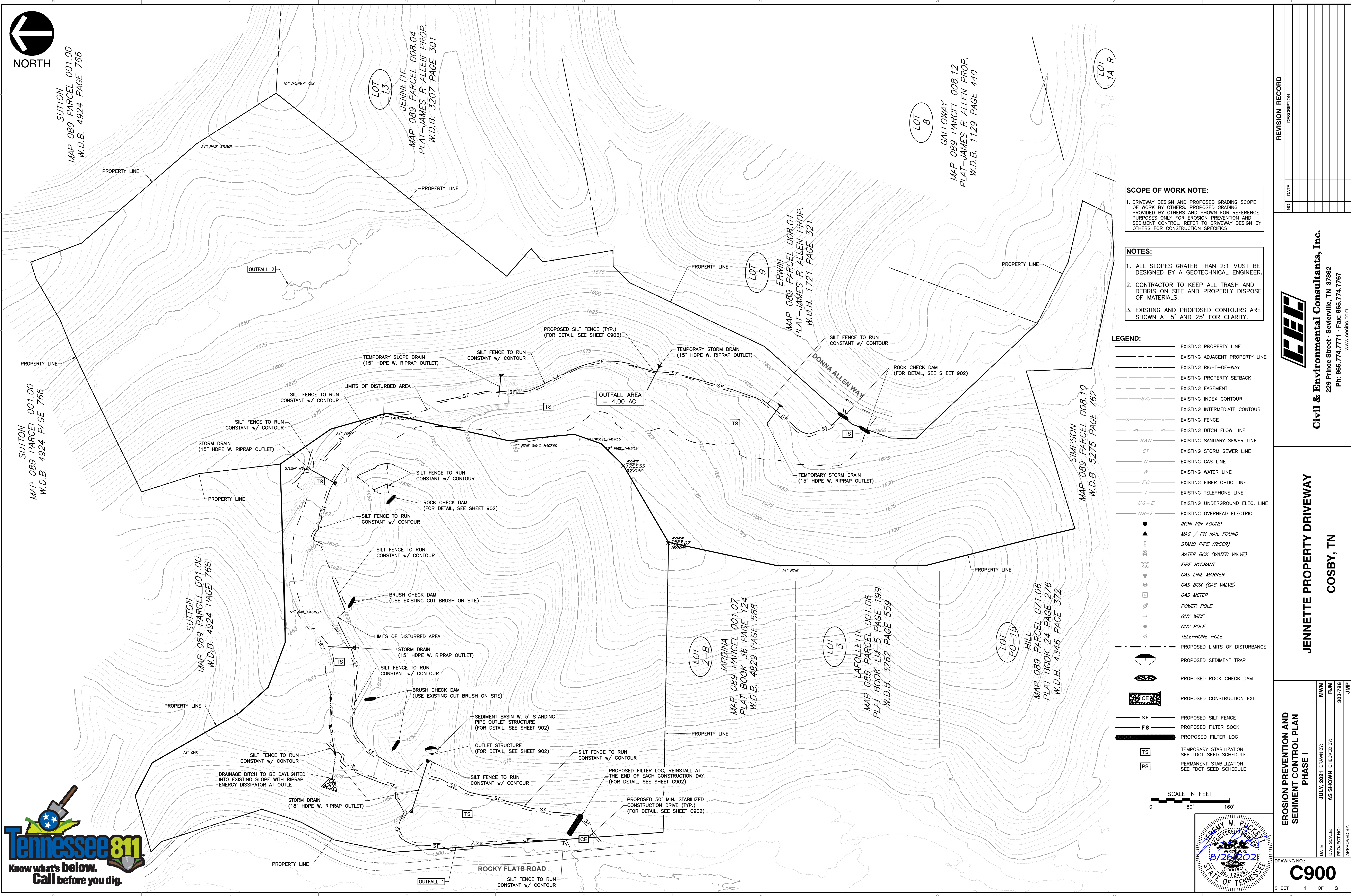

SUTTON  
MAP 089 PARCEL 001.00  
W.D.B. 4924 PAGE 766

SUTTON  
MAP 089 PARCEL 001.00  
W.D.B. 4924 PAGE 766

SUTTON  
MAP 089 PARCEL 001.00  
W.D.B. 4924 PAGE 766

LOT 13  
JENNETTE  
MAP 089 PARCEL 008.04  
PLAT-JAMES R ALLEN PROP.  
W.D.B. 3207 PAGE 301

LOT 9  
ERWIN  
MAP 089 PARCEL 008.01  
PLAT-JAMES R ALLEN PROP.  
W.D.B. 1721 PAGE 321

LOT 8  
GALLOWAY  
MAP 089 PARCEL 008.12  
PLAT-JAMES R ALLEN PROP.  
W.D.B. 1129 PAGE 440

LOT 14-R

LOT 2-B  
JARDINA  
MAP 089 PARCEL 001.07  
PLAT BOOK 36 PAGE 124  
W.D.B. 4829 PAGE 588

LOT 3  
LAFOLLETTE  
MAP 089 PARCEL 001.06  
PLAT BOOK LM-5 PAGE 199  
W.D.B. 3262 PAGE 559

LOT 15  
HILL  
MAP 089 PARCEL 071.06  
PLAT BOOK 24 PAGE 276  
W.D.B. 4346 PAGE 372

**SCOPE OF WORK NOTE:**  
1. DRIVEWAY DESIGN AND PROPOSED GRADING SCOPE OF WORK BY OTHERS. PROPOSED GRADING PROVIDED BY OTHERS AND SHOWN FOR REFERENCE PURPOSES ONLY FOR EROSION PREVENTION AND SEDIMENT CONTROL. REFER TO DRIVEWAY DESIGN BY OTHERS FOR CONSTRUCTION SPECIFICS.

**NOTES:**  
1. ALL SLOPES GRATER THAN 2:1 MUST BE DESIGNED BY A GEOTECHNICAL ENGINEER.  
2. CONTRACTOR TO KEEP ALL TRASH AND DEBRIS ON SITE AND PROPERLY DISPOSE OF MATERIALS.  
3. EXISTING AND PROPOSED CONTOURS ARE SHOWN AT 5' AND 25' FOR CLARITY.

- LEGEND:**
- EXISTING PROPERTY LINE
  - - - EXISTING ADJACENT PROPERTY LINE
  - EXISTING RIGHT-OF-WAY
  - - - EXISTING PROPERTY SETBACK
  - - - EXISTING EASEMENT
  - EXISTING INDEX CONTOUR
  - EXISTING INTERMEDIATE CONTOUR
  - EXISTING FENCE
  - EXISTING DITCH FLOW LINE
  - SAN EXISTING SANITARY SEWER LINE
  - ST EXISTING STORM SEWER LINE
  - G EXISTING GAS LINE
  - W EXISTING WATER LINE
  - FO EXISTING FIBER OPTIC LINE
  - T EXISTING TELEPHONE LINE
  - UG-E EXISTING UNDERGROUND ELEC. LINE
  - OH-E EXISTING OVERHEAD ELECTRIC
  - IRON PIN FOUND
  - ▲ MAG / PK NAIL FOUND
  - STAND PIPE (RISER)
  - WATER BOX (WATER VALVE)
  - FIRE HYDRANT
  - GAS LINE MARKER
  - GAS BOX (GAS VALVE)
  - GAS METER
  - POWER POLE
  - GUY WIRE
  - GUY POLE
  - TELEPHONE POLE
  - - - PROPOSED LIMITS OF DISTURBANCE
  - PROPOSED SEDIMENT TRAP
  - PROPOSED ROCK CHECK DAM
  - PROPOSED CONSTRUCTION EXIT
  - SF PROPOSED SILT FENCE
  - FS PROPOSED FILTER SOCK
  - PROPOSED FILTER LOG
  - TS TEMPORARY STABILIZATION SEE TDOT SEED SCHEDULE
  - PS PERMANENT STABILIZATION SEE TDOT SEED SCHEDULE

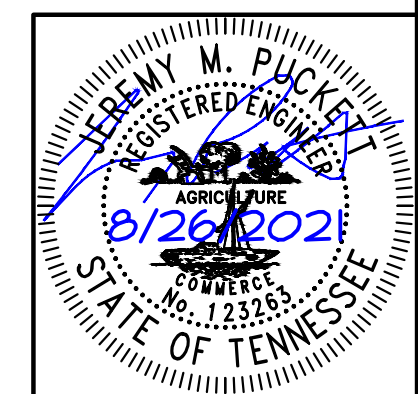
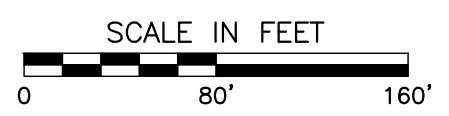

NO.	DATE	DESCRIPTION

**Civil & Environmental Consultants, Inc.**  
229 Prince Street, Sevierville, TN 37862  
Ph: 865.774.7771 • Fax: 865.774.7767  
www.cecinc.com

**JENNETTE PROPERTY DRIVEWAY**  
**EROSION PREVENTION AND SEDIMENT CONTROL PLAN PHASE I**

DATE: JULY, 2021  
DRAWN BY: MWM  
PROJECT NO: AS SHOWN  
CHECKED BY: RJM  
303-786  
APPROVED BY: JWP

DRAWING NO: **C900**  
SHEET 1 OF 3



A:\100-0001\1001-7981-0000\Draw\1001-7981-0000.dwg (C900) LS:06/26/2021 12:50 PM

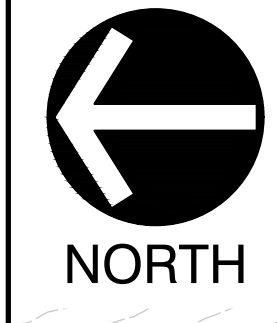
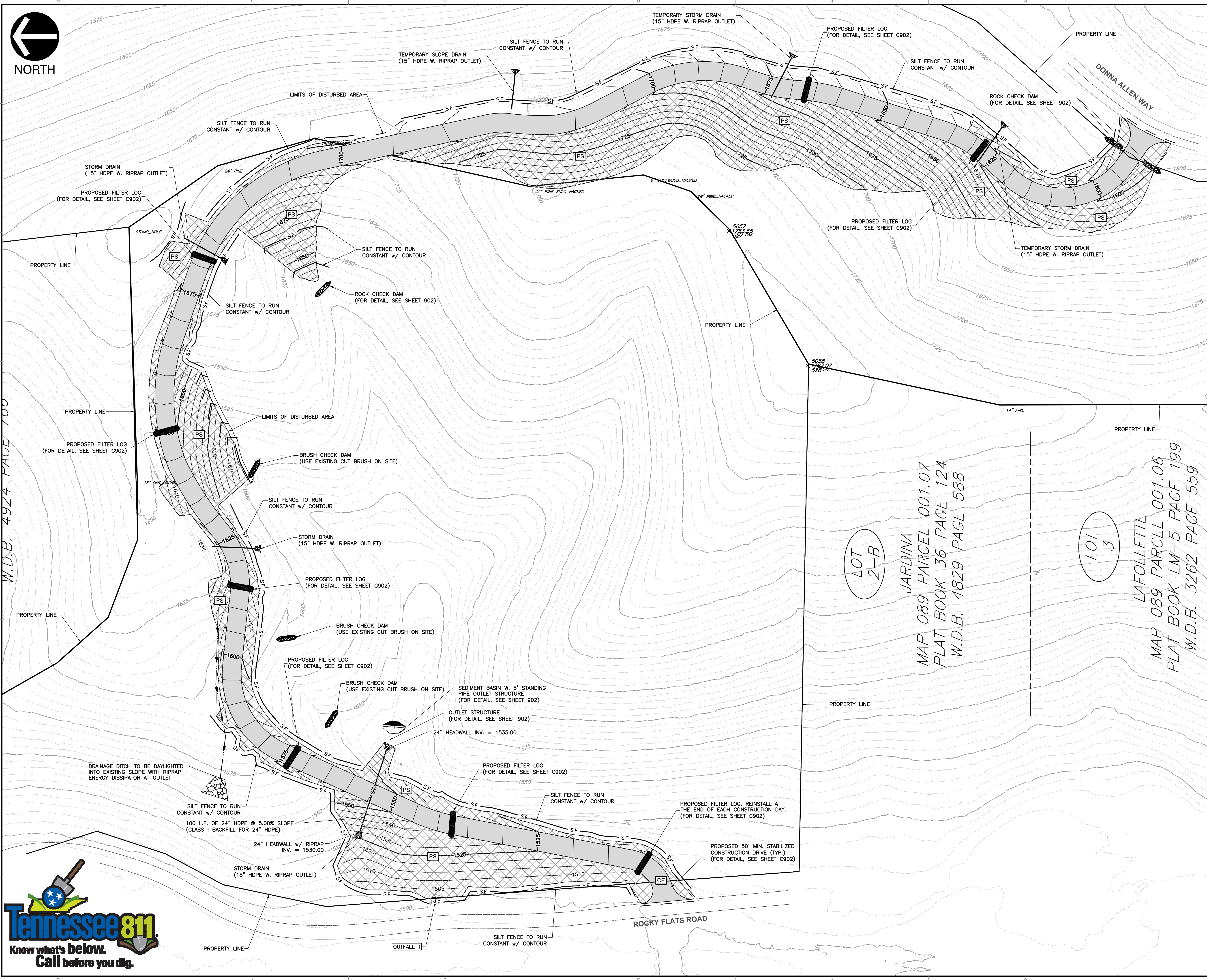

**SCOPE OF WORK NOTE:**  
 1. DRIVEWAY DESIGN AND PROPOSED GRADING SCOPE OF WORK BY OTHERS. PROPOSED GRADING PROVIDED BY OTHERS AND SHOWN FOR REFERENCE PURPOSES ONLY FOR EROSION PREVENTION AND SEDIMENT CONTROL. REFER TO DRIVEWAY DESIGN BY OTHERS FOR CONSTRUCTION SPECIFICS.

**NOTES:**  
 1. ALL SLOPES GRATER THAN 2:1 MUST BE DESIGNED BY A GEOTECHNICAL ENGINEER.  
 2. CONTRACTOR TO KEEP ALL TRASH AND DEBRIS ON SITE AND PROPERLY DISPOSE OF MATERIALS.  
 3. EXISTING AND PROPOSED CONTOURS ARE SHOWN AT 5' AND 25' FOR CLARITY.

- LEGEND:**
- EXISTING PROPERTY LINE
  - - - EXISTING ADJACENT PROPERTY LINE
  - - - EXISTING RIGHT-OF-WAY
  - - - EXISTING PROPERTY SETBACK
  - - - EXISTING EASEMENT
  - 5.00 — EXISTING INDEX CONTOUR
  - 10.00 — EXISTING INTERMEDIATE CONTOUR
  - x — x — EXISTING FENCE
  - x — x — EXISTING DITCH FLOW LINE
  - SAN — EXISTING SANITARY SEWER LINE
  - ST — EXISTING STORM SEWER LINE
  - G — EXISTING GAS LINE
  - W — EXISTING WATER LINE
  - FG — EXISTING FIBER OPTIC LINE
  - T — EXISTING TELEPHONE LINE
  - UG-E — EXISTING UNDERGROUND ELEC. LINE
  - OH-E — EXISTING OVERHEAD ELECTRIC
  - IRON PIN FOUND
  - ▲ MAG / PK NAIL FOUND
  - STAND PIPE (RISER)
  - WATER BOX (WATER VALVE)
  - FIRE HYDRANT
  - GAS LINE MARKER
  - GAS BOX (GAS VALVE)
  - GAS METER
  - POWER POLE
  - GUY WIRE
  - GUY POLE
  - TELEPHONE POLE
  - - - PROPOSED LIMITS OF DISTURBANCE
  - ▒ PROPOSED ROCK CHECK DAM
  - ▒ PROPOSED CONSTRUCTION EXIT
  - SF — PROPOSED SILT FENCE
  - FS — PROPOSED FILTER SOCK
  - — PROPOSED FILTER LOG
  - TS — TEMPORARY STABILIZATION SEE TDOT SEED SCHEDULE
  - PS — PERMANENT STABILIZATION SEE TDOT SEED SCHEDULE
  - ▒ EROSION CONTROL MATTING FOR 2:1 SLOPES.

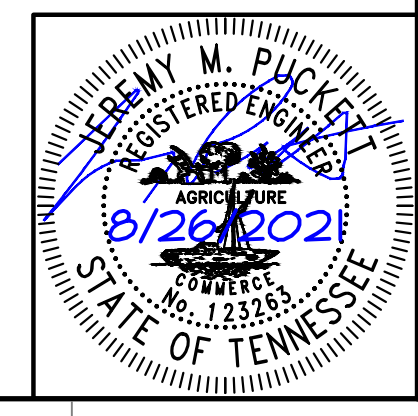

NO.	DATE	DESCRIPTION

**Civil & Environmental Consultants, Inc.**  
 229 Prince Street - Sevierville, TN 37862  
 Ph: 865.774.7771 - Fax: 865.774.7767  
 www.cecinc.com

**JENNETTE PROPERTY DRIVEWAY**  
**EROSION PREVENTION AND SEDIMENT CONTROL PLAN PHASE II**  
**COSBY, TN**

DATE: JULY, 2021 DRAWN BY: MWM  
 DWG SCALE: AS SHOWN CHECKED BY: RJM  
 PROJECT NO: 303-786  
 APPROVED BY: JMP

APPROVED BY: **C901**

A:\100-001\101-7981-0000\Draw\101-7981-0000.dwg(C901) LS:08/26/2021 12:51 PM  
 L.P. 8/13/2021 12:51 PM



# EROSION AND SEDIMENT CONTROL NOTES:

- A SPECIFIC INDIVIDUAL SHALL BE DESIGNATED TO BE RESPONSIBLE FOR EROSION AND SEDIMENT CONTROLS ON PROJECT SITE. THIS INDIVIDUAL MUST HAVE COMPLETED THE FUNDAMENTALS OF EROSION PREVENTION AND SEDIMENT CONTROL COURSE OR AN EQUIVALENT COURSE.
- REFER TO THE TENNESSEE EROSION AND SEDIMENT CONTROL HANDBOOK FOR DESIGN CRITERIA AND GUIDELINES FOR EROSION CONTROL MEASURES.
- CLEARING AND GRUBBING MUST BE HELD TO THE MINIMUM NECESSARY FOR GRADING AND EQUIPMENT OPERATION.
- CONSTRUCTION MUST BE SEQUENCED TO MINIMIZE THE EXPOSURE TIME OF CLEARED SURFACE AREA.
- CONSTRUCTION STAGING AND PHASING IS CRITICAL TO REDUCING SEDIMENT RUNOFF FROM SITE.
- EROSION CONTROL MEASURES MUST BE IN PLACE AND FUNCTIONAL BEFORE EARTH MOVING OPERATIONS BEGIN, AND MUST BE PROPERLY CONSTRUCTED AND MAINTAINED THROUGHOUT THE CONSTRUCTION PERIOD.
- ALL EROSION CONTROL MEASURES SHALL BE CHECKED TWICE WEEKLY AND AFTER EACH RAINFALL. CHECK DAILY DURING PROLONGED RAINFALL.
- CONSTRUCTION DEBRIS MUST BE KEPT FROM ENTERING THE STORM MANAGEMENT SYSTEM.
- STOCKPILED SOIL SHALL BE PROTECTED AND LOCATED FAR ENOUGH FROM STREAMS AND DRAINAGEWAYS SO THAT RUNOFF CANNOT CARRY SEDIMENT DOWNSTREAM.
- VEGETATIVE GROUND COVER SHALL NOT BE DESTROYED, REMOVED OR DISTURBED MORE THAN 10 CALENDAR DAYS PRIOR TO GRADING.
- TEMPORARY SOIL STABILIZATION WITH APPROPRIATE ANNUAL VEGETATION SHALL BE APPLIED ON AREAS THAT WILL REMAIN UNFINISHED FOR MORE THAN 14 CALENDAR DAYS.
- PERMANENT SOIL STABILIZATION WITH PERENNIAL VEGETATION SHALL BE APPLIED AS SOON AS PRACTICAL AFTER FINAL GRADING. CONTRACTOR SHALL INSPECT THE SITE PERIODICALLY TO REPAIR AND RE-ESTABLISH VEGETATION TO DAMAGED AREAS.
- STAKED AND ENTRENCHED SILT FENCE MUST BE INSTALLED ALONG THE BASE OF ALL FILLS AND CUTS, ON THE DOWNHILL SIDES OF STOCKPILED SOIL, AND ALONG STREAM BANKS IN CLEARED AREAS TO PREVENT EROSION INTO STREAMS. SILT FENCE MAY BE REMOVED AT THE BEGINNING OF THE WORK DAY, BUT MUST BE REPLACED AT THE END OF THE WORK DAY OR PRIOR TO FORECASTING RAIN EVENTS.
- WHERE APPROPRIATE, SURFACE WATER FLOWING TOWARD CONSTRUCTION AREA SHALL BE DIVERTED AROUND THE CONSTRUCTION AREA USING DIKES, TO REDUCE EROSION POTENTIAL.
- PLACEMENT AND MAINTENANCE OF CHECK DAMS SHALL BE AS SPECIFIED ON PLANS AND AS REQUIRED IN THE TENNESSEE EROSION AND SEDIMENT CONTROL HANDBOOK.
- ALL ROCK SHALL BE CLEAN, HARD ROCK CONTAINING NO SAND, DUST, OR ORGANIC MATERIAL.
- REFER TO THE TENNESSEE EROSION CONTROL HANDBOOK FOR MAINTENANCE REQUIREMENTS OF EROSION AND SEDIMENT CONTROL MEASURES.
- CONTRACTOR SHALL MAINTAIN SILT FENCES AND OTHER EROSION CONTROL DEVICES FOR THE DURATION OF THE PROJECT, TO ENSURE EFFECTIVENESS, UNTIL ACCEPTED BY THE OWNER, AT NO ADDITIONAL EXPENSE TO THE OWNER. IF CONSTRUCTION ACTIVITIES CEASE DUE TO WEATHER RELATED CAUSES, THEN THE CONTRACTOR WILL ENSURE THAT THE SITE IS PROPERLY STABILIZED AND ALL EROSION CONTROL DEVICES ARE MAINTAINED AND FUNCTIONAL DURING THOSE PERIODS OF INACTIVITY.
- CONSTRUCTION EXIT - CONTRACTOR SHALL INSTALL TEMPORARY CONSTRUCTION EXIT PRIOR TO ANY EARTHWORK OPERATIONS, CONSTRUCTION EXIT SHALL BE LOCATED AS SHOWN. CONSTRUCTION EXIT SHALL BE MAINTAINED IN A CONDITION WHICH WILL PREVENT TRACKING OR FLOW OF MUD TO PUBLIC RIGHTS-OF-WAYS. ALL MATERIAL SPILLED, DROPPED, WASHED OR TRACKED FROM VEHICLES OR SITE ONTO ADJACENT ROADWAYS SHALL BE REMOVED IMMEDIATELY FROM THE ROADWAY.
- CONTRACTOR IS RESPONSIBLE FOR CLEANING OUT AND PROPER DISPOSAL OF ALL DEBRIS WITHIN THE STORM DRAINAGE STRUCTURES, INCLUDING SILT FROM FLUMES, PIPES, ETC., PRIOR TO COMPLETION OF THE PROJECT.
- ADDITIONAL PROTECTION IN ADDITION TO THE ABOVE, SHALL BE PROVIDED THAT WILL PREVENT SILT FROM LEAVING THE SITE DUE TO UNFORESEEN CONDITIONS OR ACCIDENTS.
- STREAMS SHALL NOT BE USED AS TRANSPORTATION ROUTES FOR EQUIPMENT CROSSINGS MUST BE LIMITED TO ONE POINT. A STABILIZED PAD OF CLEAN AND PROPERTY SIZED SHOT ROCK MUST BE USED AT THE CROSSING POINT.
- MEASURES SHOWN FOR SEDIMENT AND EROSION CONTROL REPRESENT THE MINIMUM ANTICIPATED. ADDITIONAL PROTECTION SHALL BE PROVIDED AS NECESSARY THAT WILL PREVENT SEDIMENT FROM LEAVING THE SITE DUE TO UNFORESEEN CONDITIONS OR ACCIDENTS.
- THE GRADING CONTRACTOR AND BUILDING CONTRACTOR WILL REFRAIN FROM DOING ANY WORK OUTSIDE OF THE DELINEATED LIMITS OF DISTURBANCE.
- ROADS SHALL BE STABILIZED BY APPLYING STONE ONCE SUBGRADE ELEVATION IS ACHIEVED.
- ALL SILT FENCE IS TO BE TYPE A EXCEPT WHERE SPECIFIED DIFFERENTLY.
- EROSION CONTROL MATTING TO BE JUTE MESH (OR APPROVED EQUAL) AND INSTALLED ACCORDING TO MANUFACTURER'S RECOMMENDATIONS.
- THE EROSION PREVENTION AND SEDIMENT CONTROLS FOR THIS SITE HAVE BEEN DESIGNED FOR THE 5-YEAR 24 HOUR STORM IN ACCORDANCE WITH THE TENNESSEE GENERAL PERMIT FOR STORMWATER DISCHARGES FOR CONSTRUCTION ACTIVITIES (5-4.1.A)

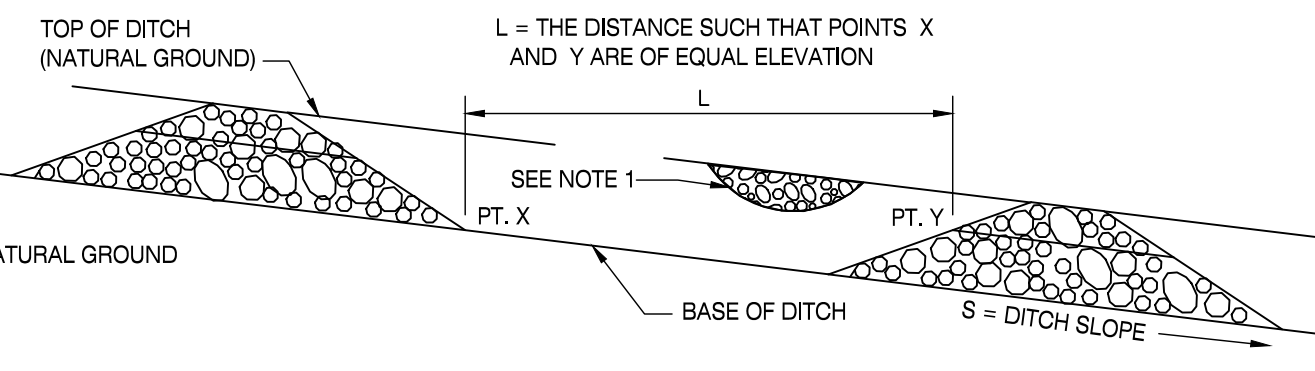
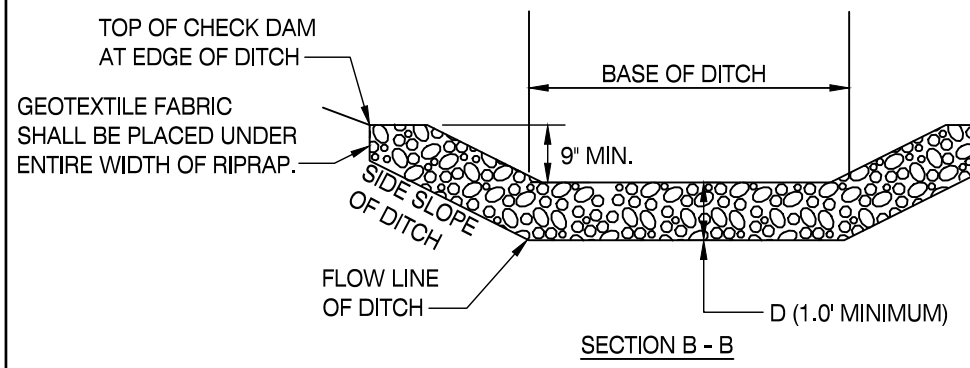
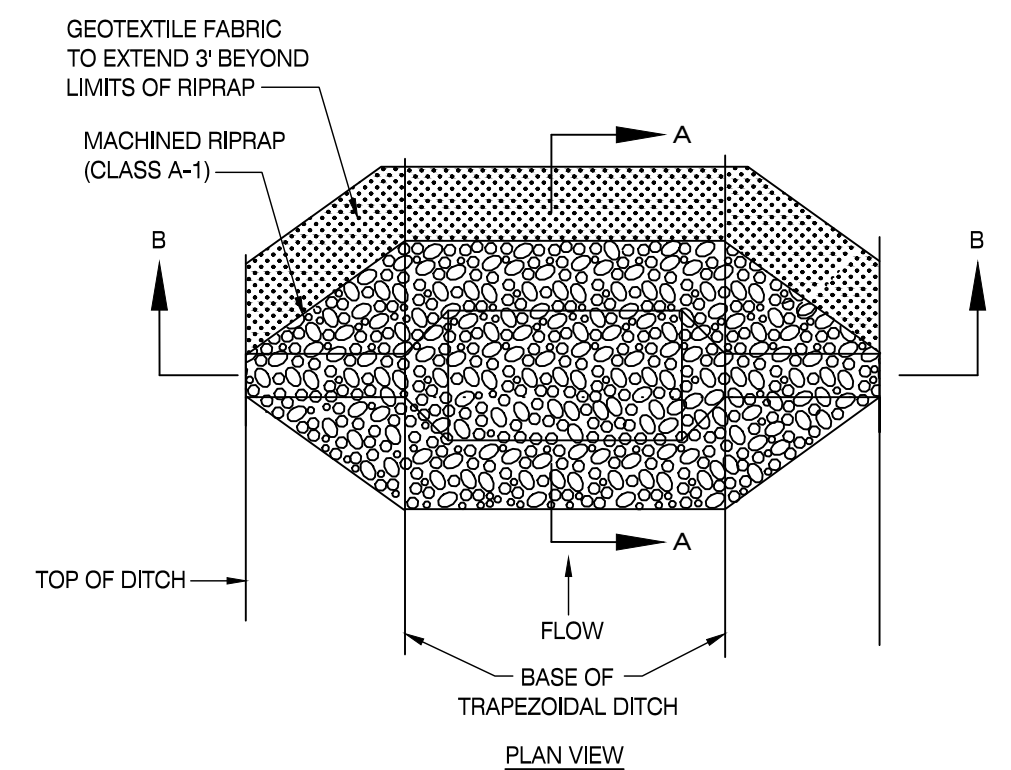

- NOTES:**
- FILL LOW AREAS ALONG TOP OF BANK TO PREVENT BACKWATER FROM EXITING DITCH.
  - WEIR FLOW DEPTH BASED UPON 2yr/24hr STORM EVENT OR 5yr/24hr STORM EVENT.

**CHECK DAM**

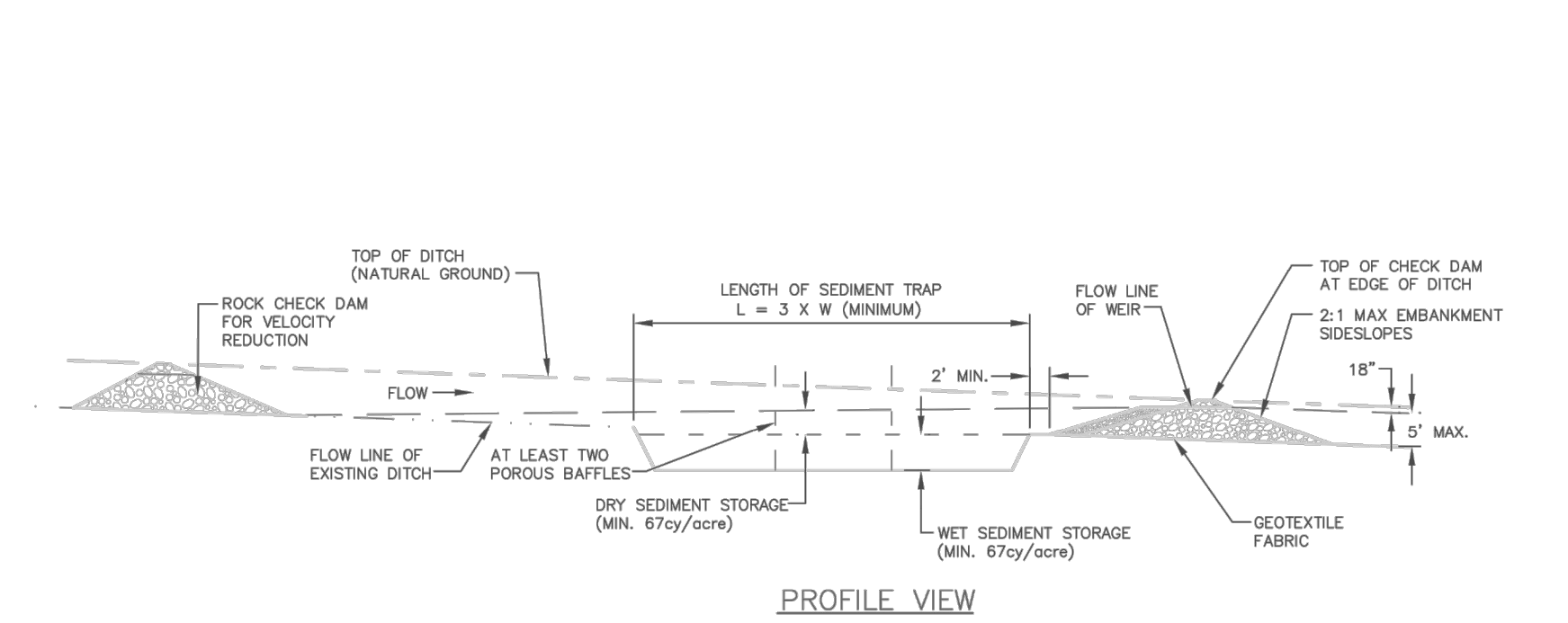
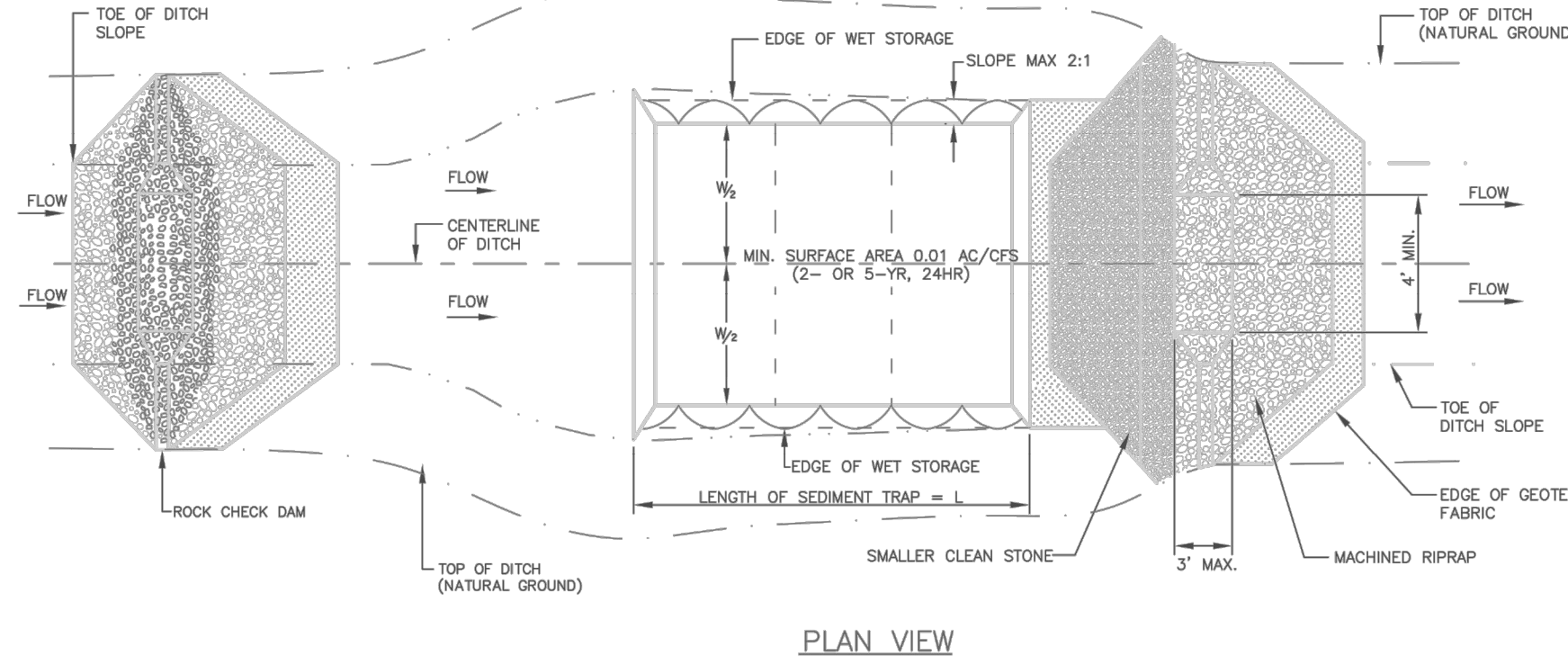

**SEDIMENT TRAP DETAIL (TDEC)**

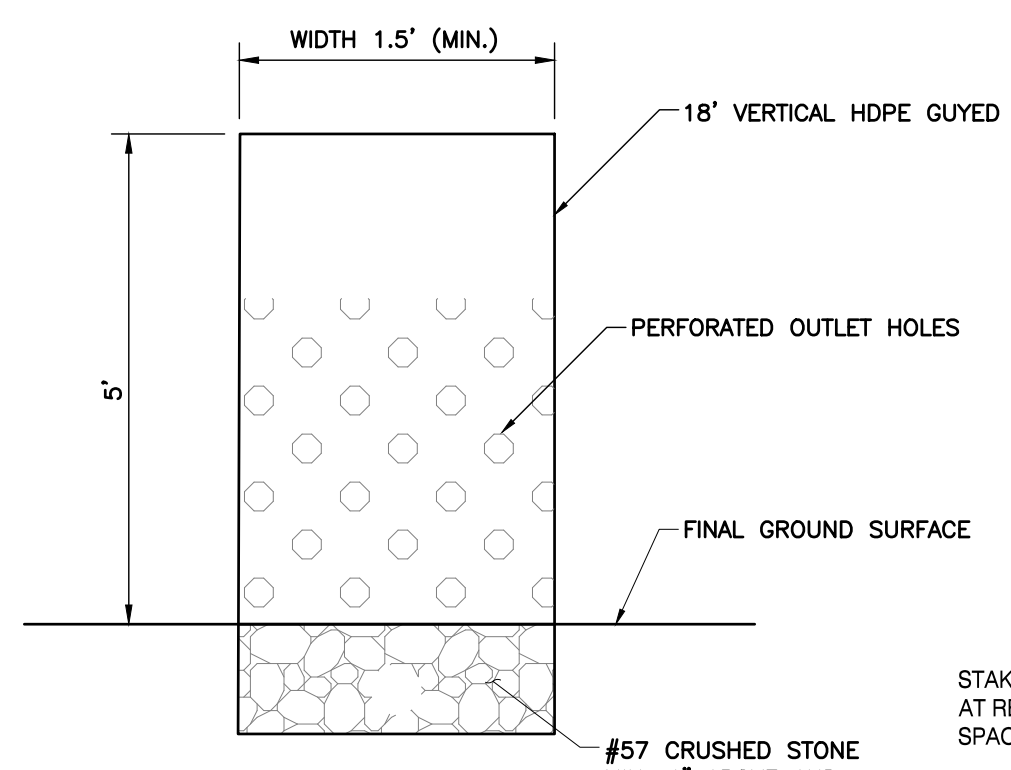

- NOTE:** INSTALL OUTLET DRAINS AT LOCATIONS SHOWN ON PLAN AND AT WET AREAS AS DIRECTED BY OWNERS REPRESENTATIVE. OUTLET BEYOND LIMITS OF NEW FILL.

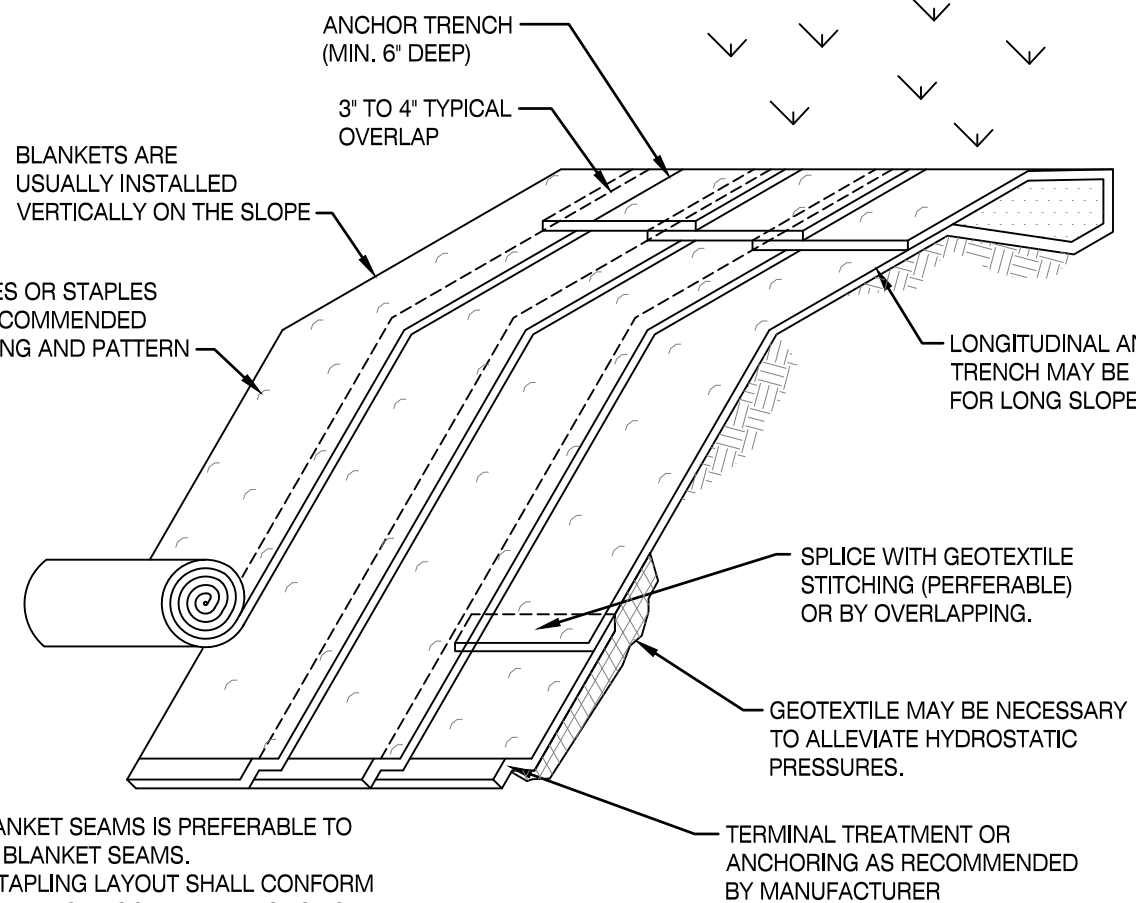

- NOTES:**
- STITCHING BLANKET SEAMS IS PREFERABLE TO OVERLAPPING BLANKET SEAMS.
  - STAKING OR STAPLING LAYOUT SHALL CONFORM TO MANUFACTURER'S RECOMMENDATIONS FOR SLOPE AND GRADE.
  - ALL MATERIALS SHALL CONFORM TO TDEC EROSION CONTROL SPEC. MA-3.

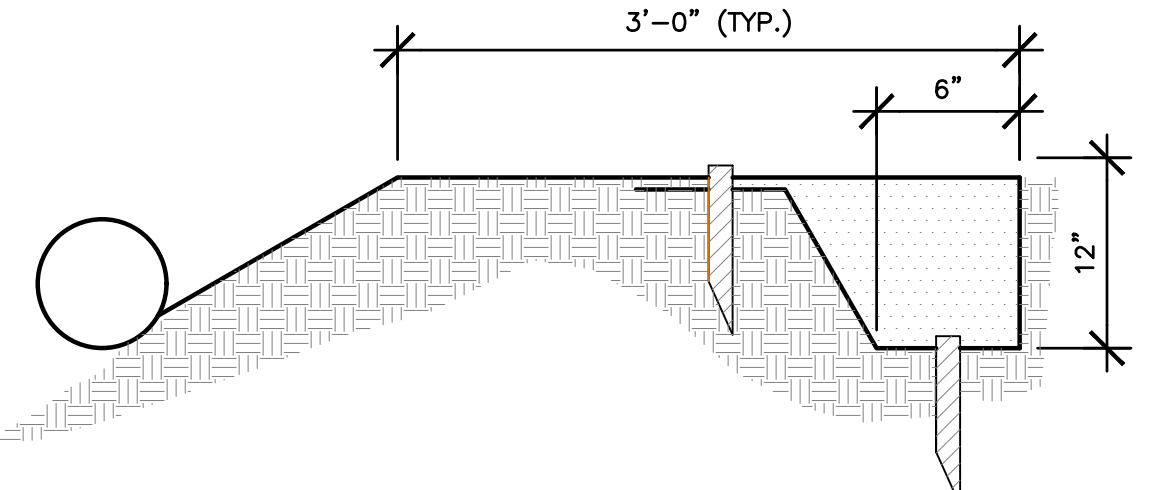

**SLOPE MATTING DETAIL**

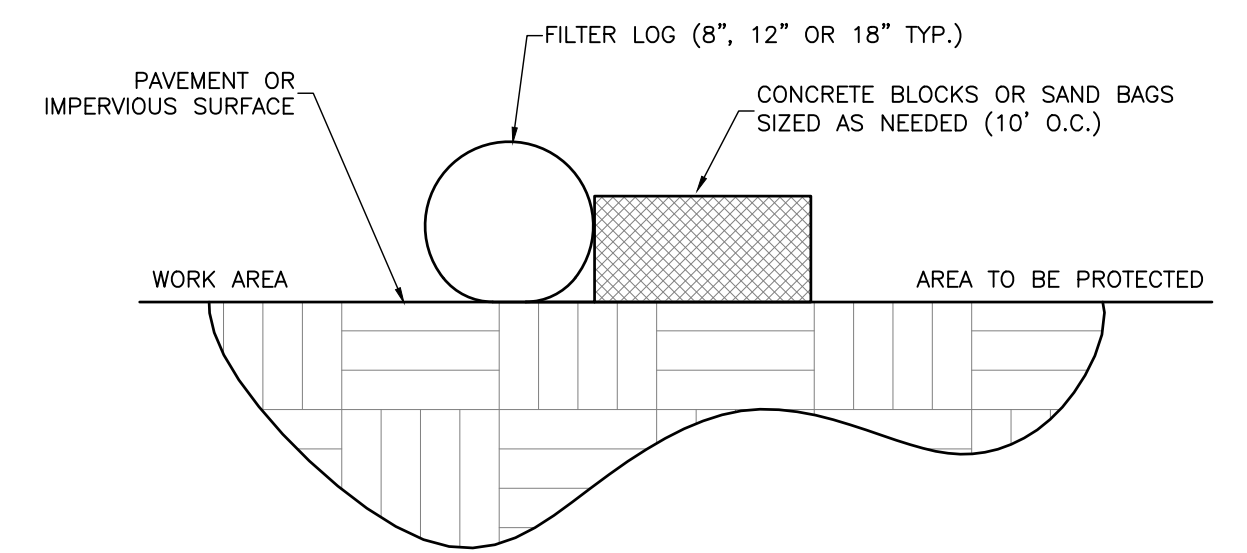

**FILTER LOG ON PAVEMENT DETAIL 0015**

- NOTES:**
- ALL MATERIALS TO MEET MARYLAND DEPARTMENT OF ENVIRONMENT SPECIFICATIONS
  - FILTER MEDIA TO BE DISPERSED ON SITE, AS DETERMINED BY ENGINEER

**PLAN**

**FILTER LOG ON PAVEMENT DETAIL 0015**

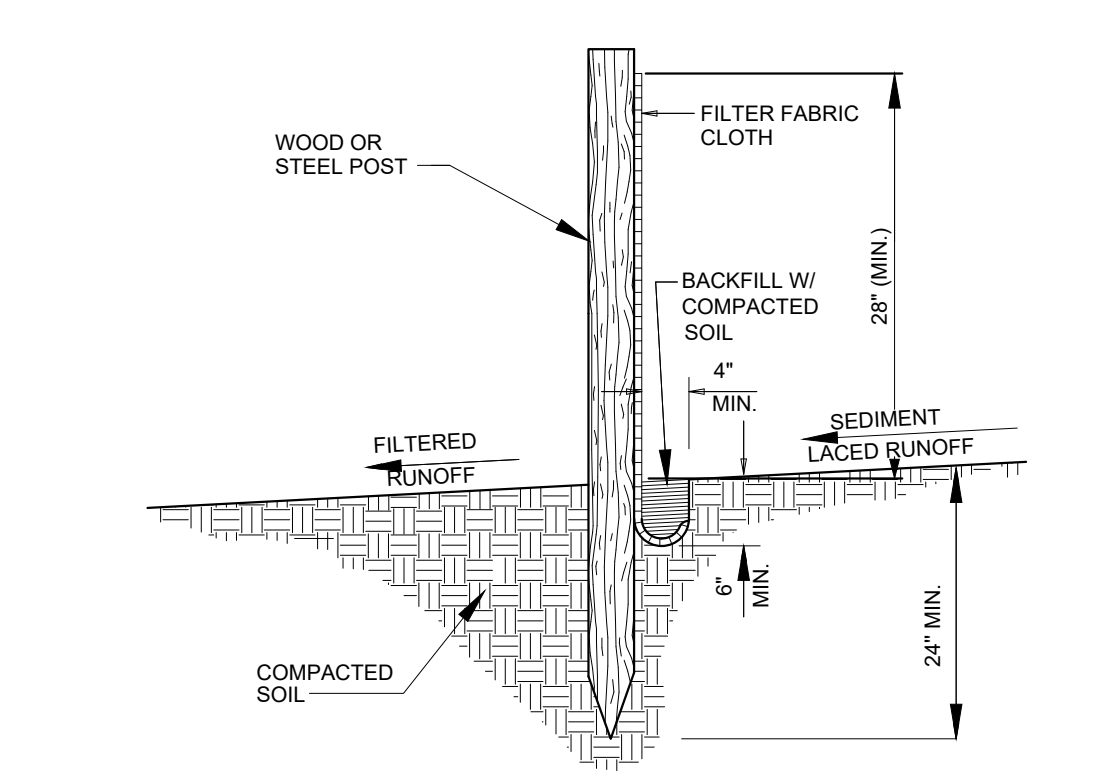
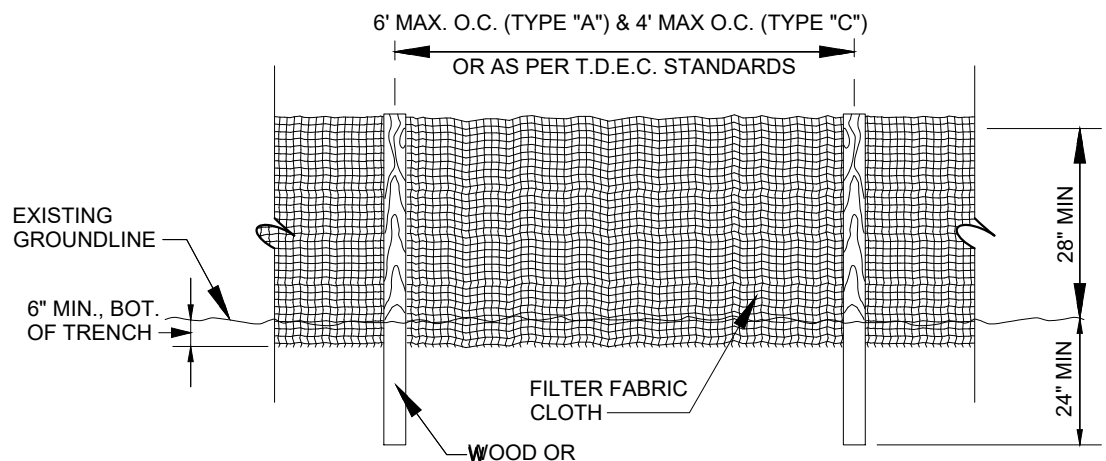

**SILT FENCE BARRIER**

**NOTES:**

- FILTER CLOTH SHALL MEET THE REQUIREMENTS OF THE STANDARD SPECIFICATION FOR GEOTEXTILES AASHTO DESIGNATION: M288, SEDIMENT CONTROL, SELF SUPPORTED.
- THE FILTER MATERIAL SHALL BE STAPLED TO THE STAKES. HEAVY DUTY WIRE STAPLES WITH 1/2 INCH WIDTH SHALL BE USED AND EVENLY SPACED WITH AT LEAST FOUR PER POST FOR SILT FENCES AND THREE PER POST FOR FILTER BARRIERS. FILTER MATERIAL SHALL NOT BE STAPLED TO EXISTING TREES.
- MINIMUM 2" X 2" (NOMINAL) - (1.5" X 1.5" ACTUAL) (2.25 SQ. IN.) HARDWOOD POST (OAK OR HICKORY) - LENGTH AS INDICATED MINIMUM 1.33 LB./FT. STEEL POST (STD. OR U SECTION).
- WHEN STEEL POSTS ARE USED THEY SHALL HAVE A PROTECTION FOR FASTENING WIRE TO THEM. THE WIRE FASTENERS SHOULD BE EVENLY SPACED WITH AT LEAST FIVE PER POST.
- BINDING WIRE OR TWINE SHALL REMAIN ON STRAW BALES.
- PLACE STRAW BALES ON DOWNSTREAM SIDE OF SILT FENCE AS REQUIRED.
- STRAW BALES TO BE PLACED END TO END UP AGAINST THE SILT FENCE.

TYPE A SILT FENCE - THIS 36-INCH WIDE FILTER FABRIC SHOULD BE USED ON DEVELOPMENTS WHERE THE LIFE OF THE PROJECT IS SIX MONTHS OR LONGER.

TYPE C SILT FENCE - TYPE C SILT FENCE IS 36-INCHES WIDE WITH WIRE REINFORCEMENT. THE WIRE REINFORCEMENT IS NECESSARY BECAUSE THIS FABRIC ALLOWS FOR ALMOST THREE TIMES THE FLOW RATE AS TYPE A SILT FENCE. TYPE C SILT FENCE SHOULD BE USED WHERE RUNOFF FLOWS OR VELOCITIES ARE PARTICULARLY HIGH OR WHERE SLOPES EXCEED A VERTICAL HEIGHT OF 10 FEET.

**PERMANENT SEEDING MIXTURES**

SEEDING DATES	GRASS SEED	PERCENTAGES
FEBRUARY 1 TO JULY 1	KENTUCKY 31 FESCUE	88%
	ENGLISH RYE	12%
JUNE 1 TO AUGUST 15	KENTUCKY 31 FESCUE	60%
	ENGLISH RYE	25%
AUGUST 1 TO DECEMBER 1	GERMAN MILLET	15%
	KENTUCKY 31 FESCUE	70%
	WHITE CLOVER	10%
DECEMBER 1 TO FEBRUARY 1	KENTUCKY 31 FESCUE	83%
	ENGLISH RYE	17%

**SOURCE: TDOT STANDARDS SPECIFICATIONS**

**TEMPORARY SEEDING MIXTURES**

SEEDING DATES	GRASS SEED	PERCENTAGES
JANUARY 1 TO MAY 1	ITALIAN RYE	50%
	SUMMER OATS	50%
MAY 1 TO JULY 15	SUDAN-SORGHUM	100%
MAY 1 TO JULY 15	STARR MILLET	100%
JULY 15 TO JANUARY 1	BALBOA RYE	67%
	ITALIAN RYE	33%

**SOURCE: TDOT STANDARDS SPECIFICATIONS**

**SEEDING SCHEDULE**  
N.T.S.

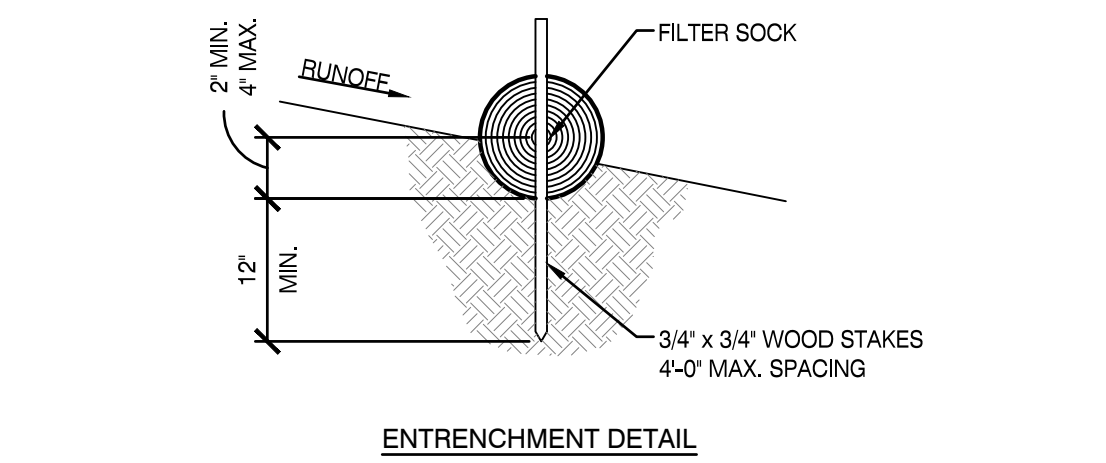
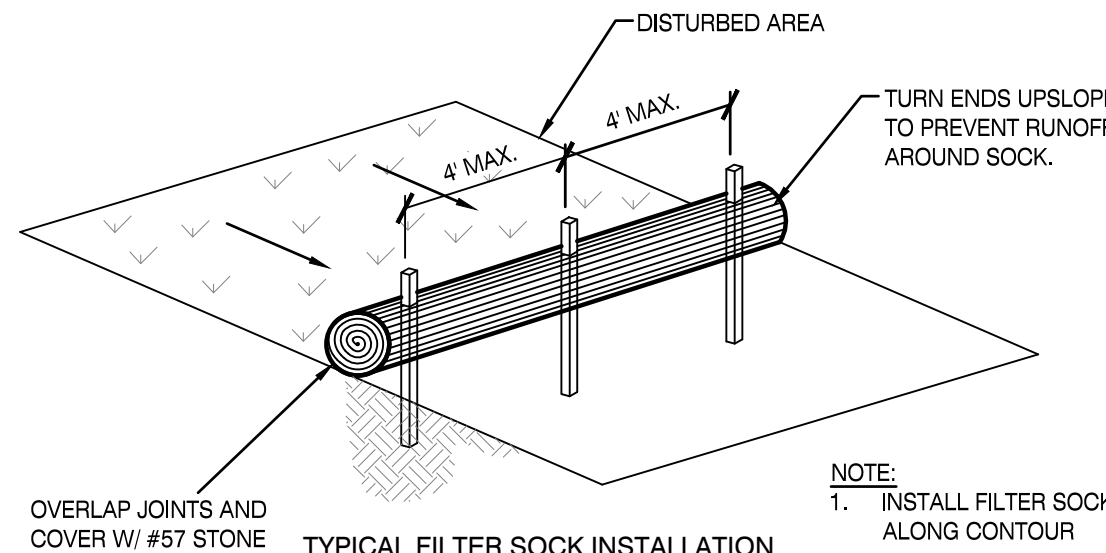

**FILTER SOCK DETAIL**

**REVISION RECORD**

NO.	DATE	DESCRIPTION

**Civil & Environmental Consultants, Inc.**  
229 Prince Street - Sevierville, TN 37862  
Ph: 865.774.7771 - Fax: 865.774.7767  
www.cecinc.com

**JENNETTE PROPERTY DRIVEWAY**  
**COSBY, TN**

**EROSION PREVENTION AND SEDIMENT CONTROL DETAILS**

DATE:	DRAWN BY:	M/M/M
JULY, 2021	AS SHOWN	R/J/M
PROJECT NO:	CHECKED BY:	303-786
APPROVED BY:	JIMP	

DRAWING NO. **C902**  
SHEET OF

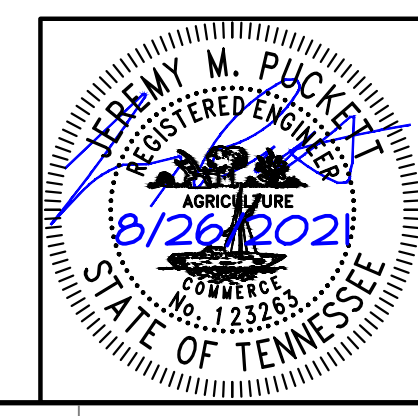

---

**EXHIBIT B:  
LOCATION REFERENCES**

---

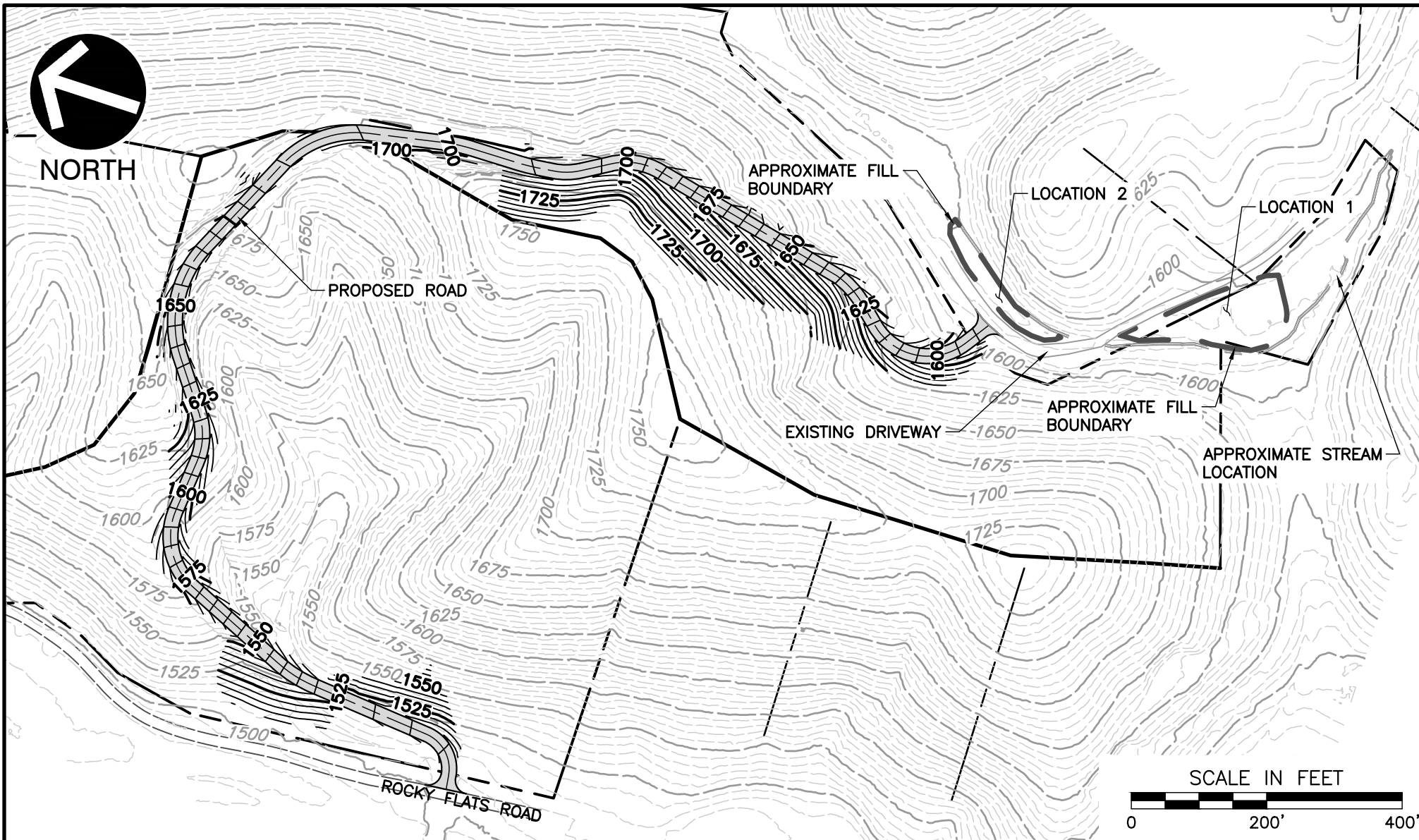

  
**Civil & Environmental Consultants, Inc.**  
 229 Prince Street · Sevierville, TN 37862  
 Ph: 865.774.7771 · Fax: 865.774.7767  
[www.cecinc.com](http://www.cecinc.com)

SMOKY MTN. OUTDOORS UNLIMITED  
 JENNETTE PROPERTY DRIVEWAY  
 ROCKY FLATS ROAD  
 COSBY, TN.

**EXHIBIT B**

DRAWN BY:	AGA	CHECKED BY:	RJM
DATE:	MARCH 2022	DWG SCALE:	1"=200'

APPROVED BY:	EXHIBIT:
PROJECT NO: 303-786	<b>EX B</b>



---

**EXHIBIT C:  
CORRECTIVE ACTION PLAN DRAWINGS**

---

**LOCATION 1**

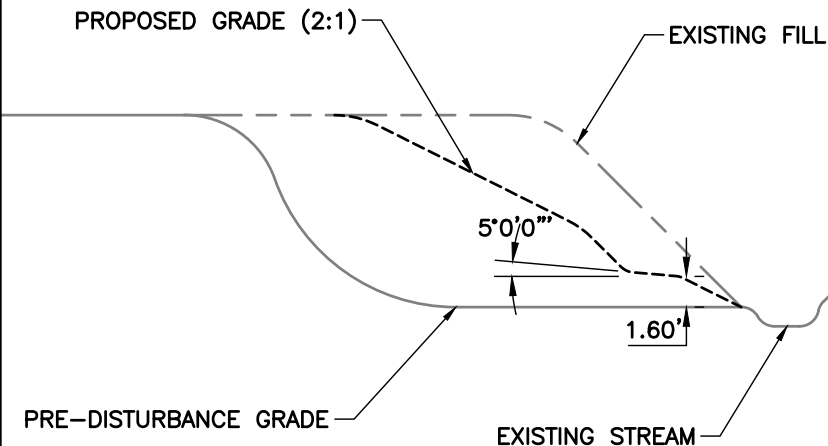

**CROSS-SECTION VIEW**  
(1" = 10')

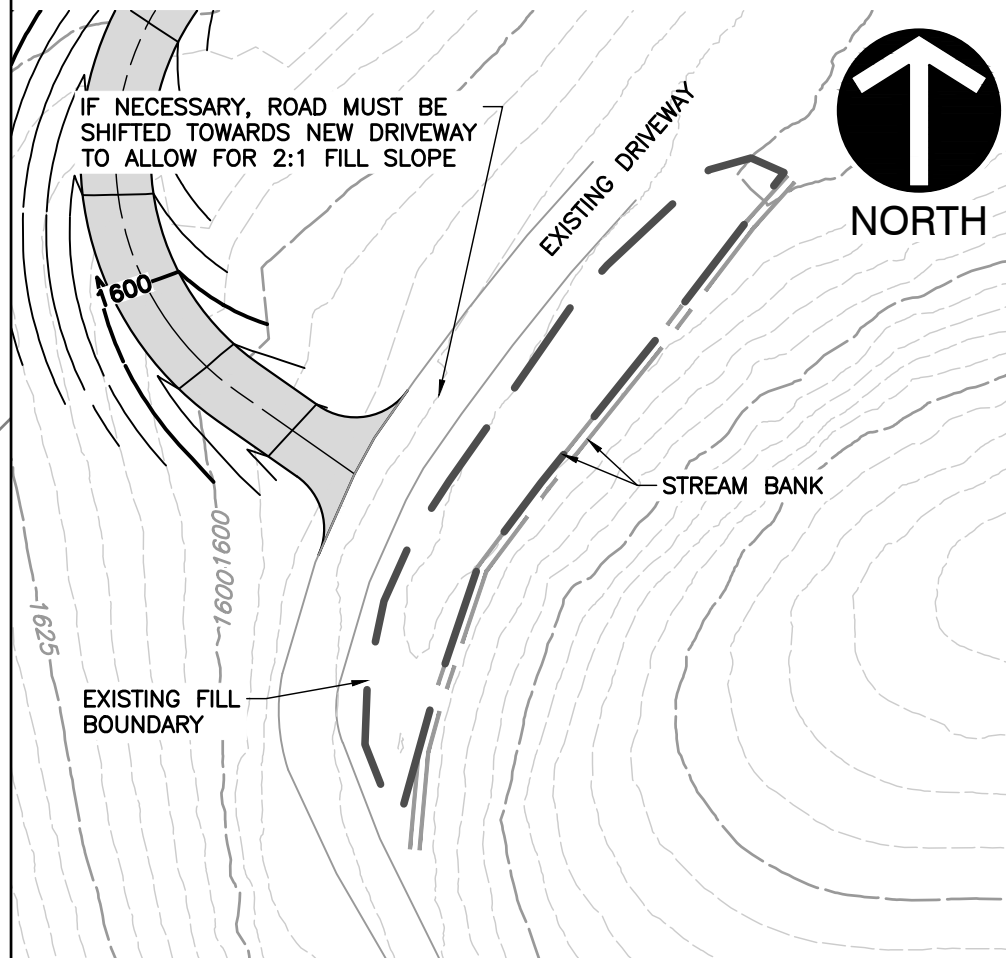

**OVERHEAD VIEW**  
(1" = 60')



**Civil & Environmental Consultants, Inc.**

229 Prince Street · Sevierville, TN 37862  
Ph: 865.774.7771 · Fax: 865.774.7767  
www.cecinc.com

SMOKY MTN. OUTDOORS UNLIMITED  
JENNETTE PROPERTY DRIVEWAY  
ROCKY FLATS ROAD  
COSBY, TN.

EXHIBIT C1

DRAWN BY:	AGA	CHECKED BY:	RJM	APPROVED BY:	EXHIBIT:
DATE:	MARCH 2022	DWG SCALE:	AS SHOWN	PROJECT NO:	303-786

**EX C1**

**LOCATION 2**

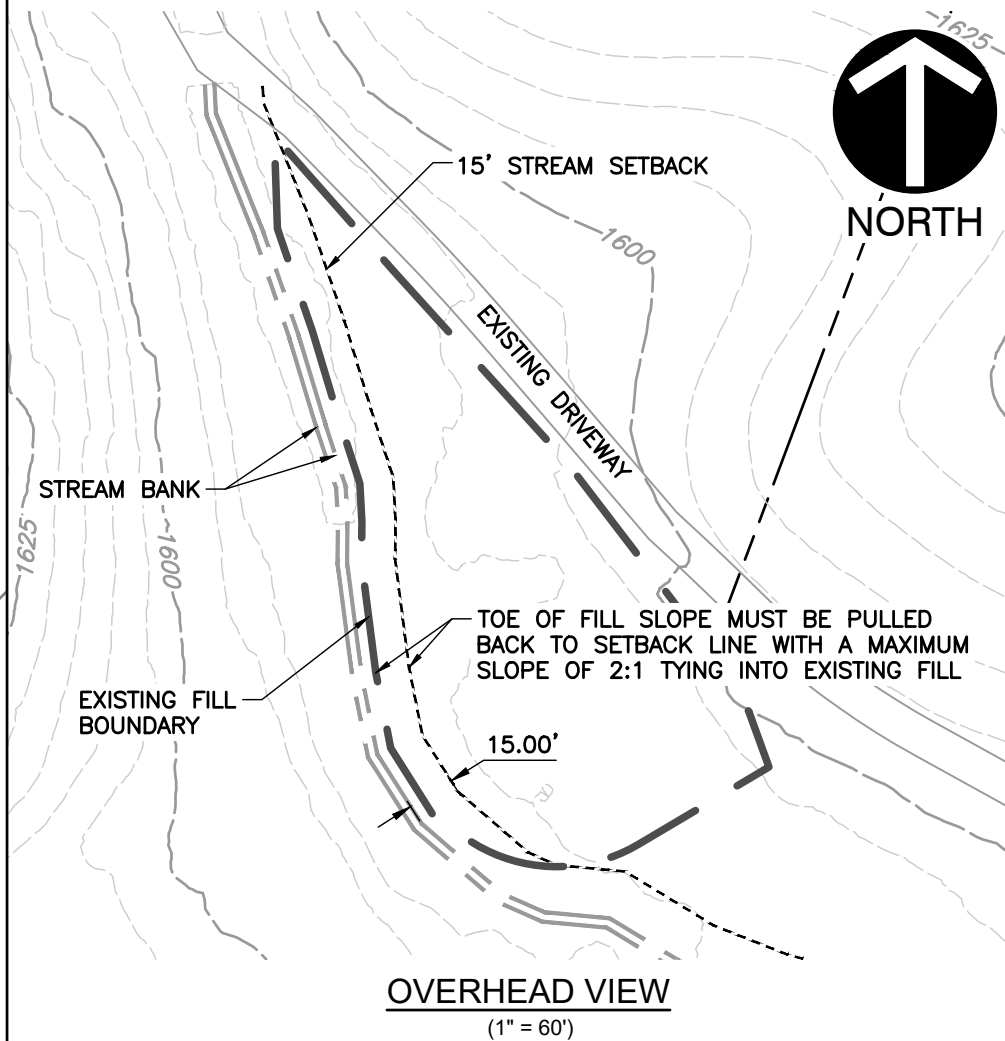
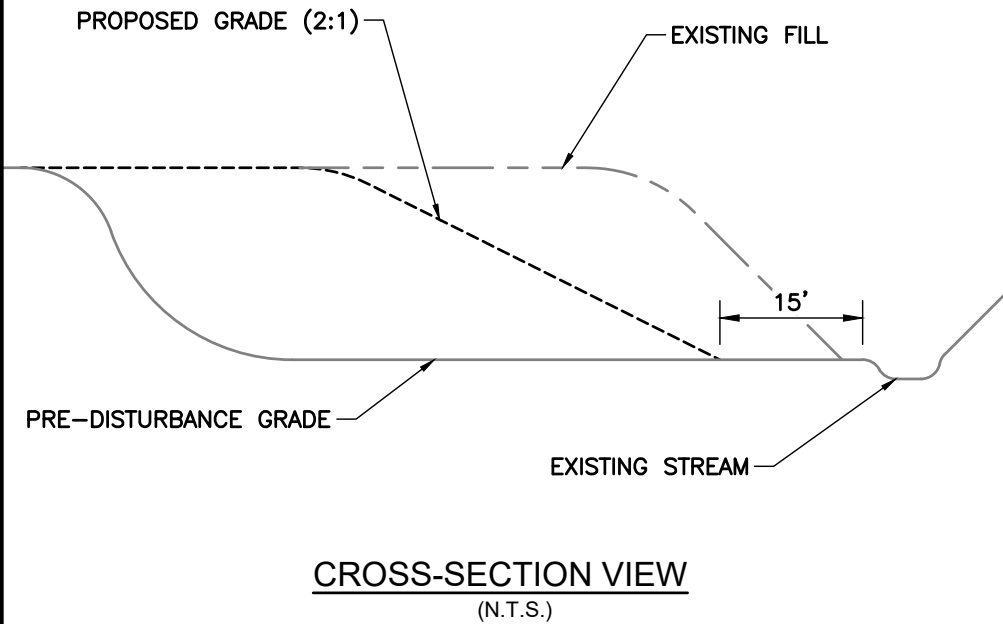

**Civil & Environmental Consultants, Inc.**  
229 Prince Street · Sevierville, TN 37862  
Ph: 865.774.7771 · Fax: 865.774.7767  
www.cecinc.com

SMOKY MTN. OUTDOORS UNLIMITED  
JENNETTE PROPERTY DRIVEWAY  
ROCKY FLATS ROAD  
COSBY, TN.

EXHIBIT C2

DRAWN BY: AGA	CHECKED BY: RJM	APPROVED BY:	EXHIBIT: EX C2
DATE: MARCH 2022	DWG SCALE: AS SHOWN	PROJECT NO: 303-786	